

- > Port size: DN 15 ... 50, flange connection, PN 40
- > With inspection certificate DIN EN 10204 - 3.1 Requirements AD 2000 A4
- > High flow rate
- > For robust industry solutions
- > Damped operation
- > Valve operates without differential pressure
- > Fluids of Group 1 and 2 acc. Pressure Equipment Directive 97/23/EC
- > Suitable for supervision Systems

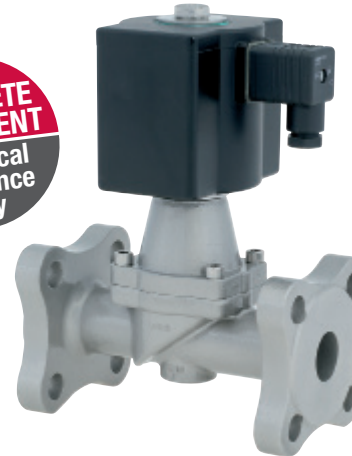

Technical features

Medium:

Slightly aggressive gases and liquid fluids
 Switching function: Normally closed
 Operation: Solenoid actuated, with forced lifting
 Mounting: Optional, preferably solenoid vertical on top

Flow direction: Determined
 Port size: DN 15, DN 20, DN 25, DN 32, DN 40, DN 50
 Operating pressure: 0 ... 25 bar (0 ... 362 psi)

Fluid temperature: -20° ... +90°C (-4° ... +194°F)
 Ambient temperature: -20° ... +50°C (-4° ... +122°F)

Material: Body: Stainless steel (1.4408)
 Seat seal: NBR
 Internal parts: Stainless steel

For contaminated fluids insertion of a strainer is recommended.

Technical data - standard models

Symbol	Orifice (mm)	Flow kv value *1 (m³/h)	Operating pressure *2 (bar)	Weight (kg)	Model Solenoid in V d.c.	Model Solenoid in V a.c.
	15	4,4	0 ... 25	4,2	8558200.8401.xxxxx	8558200.8404.xxxxx
	20	7	0 ... 25	4,6	8558300.8401.xxxxx	8558300.8404.xxxxx
	25	10,5	0 ... 25	5,1	8558400.8401.xxxxx	8558400.8404.xxxxx
	32	25	0 ... 25	9,6	8558500.8401.xxxxx	8558500.8404.xxxxx
	40	27	0 ... 25	10	8558600.8401.xxxxx	8558600.8404.xxxxx
	50	43	0 ... 25	11,5	8558700.8401.xxxxx	8558700.8404.xxxxx

xxxxx Please insert voltage and frequency codes

*1) Cv-value (US) ≈ kv value x 1,2

*2) For gases and liquid fluids up to 60 mm²/s (cSt)

Inspection certificate DIN EN 10204 - 3.1

Requirements AD 2000 A4 (W2 / W5 / W10)

12 57 333.0000

Material quality proof for:

- valve body, -cover, body screws acc. to DIN EN 10204 - 3.1
- material quality proof for fluid contacted parts acc. to DIN EN 10204 - 2.2
- function and leak test acc. to DIN EN 10204 - 3.1, leakage A acc. to DIN EN 12266-1

Option selector

8558***.***.***

Port size	Substitute
15	2
20	3
25	4
32	5
40	6
50	7
Valve options	Substitute
Normally open (NO), Mounting position: Solenoid vertical on top	01
Manual override	02
Seat seal FPM, Fluid temperature -10 ... +110°C *1)	03
Seat seal PTFE, Fluid temperature -20 ... +110°C *1), Lackage rate E acc. to DIN EN 12266-1, for fluids of group 1 and 2 of the Pressure Equipment Directive 97/23/EC	06
Seat seal EPDM, for hot water, Fluid temperature -20 ... +110°C	14
Normally open, Fluid temperature -10 ... +110°C, Seat seal FPM, Mounting position: Solenoid vertical on top *1)	17
Max. operating pressure 40 bar	22
Electrical position indicator with two limit switches (Reed contact)	23
Seat seal FPM, with larger bleed orifices in the piston, for e.g. fuel and oil, max. viscosity 80 mm ² /s (cSt), Fluid temperature -10 ... +110°C *1)	
Flanges acc.to ASME B 16.5 150 lb/sq. In.	47
Flanges acc.to ASME B 16.5 300 lb/sq. In.	48

Frequency	Substitute
See table frequency codes	xx
Voltage	Substitute
See Voltage codes	xxx
Solenoid Options	Substitute
DN 15 ... 50 Solenoid in V d.c.	8401
DN 15 ... 50 Solenoid in V a.c.	8404

Standard solenoid systems

Voltage and Frequency Solenoid 8401/8404						
Code	Code	Voltage	Frequency	Power consumption		
Voltage	Frequency			Inrush	Holding	
024	00	24 V d.c.	-	40 W	40 W	
024	49	24 V a.c. *3)	40 ... 60 Hz	45 VA	45 VA	
110	49	110 V a.c. *3)	40 ... 60 Hz	45 VA	45 VA	
120	49	120 V a.c. *3)	40 ... 60 Hz	45 VA	45 VA	
230	49	230 V a.c. *3)	40 ... 60 Hz	45 VA	45 VA	

*3) A.c. only with rectifier plug

Further versions on request!

Electrical details for all solenoid systems

Design	DIN VDE 0580
Voltage range	±10%
Duty cycle	100% ED
Protection class	EN 60529 IP65
Socket	Form A acc. to DIN EN 175301-803 (included)

According to DIN VDE 0580 at a solenoid temperature of +20°C.
At operating state temperature the input power of a coil decreases by up to ca. 30% due to physical reasons.



Additional solenoid systems

ATEX category	Protection class	Solenoid	Standard Voltages
II2GD	EEx me II T3 T 140°C	8441	24 V d.c., 110 V a.c., 230 V a.c.
II3GD	Ex nA II T4 T 135°C	8426 *2)	24 V d.c., 110 V a.c., 230 V a.c.
II2GD	Ex d IIC T4 and T5 T 130°C resp. T 95°C	8920	24 V d.c., 110 V a.c., 230 V a.c.

Attention!

The conditions imposed on the Ex approvals lead to reduction of the permissible standard temperature ranges in the cases of explosion protected solenoids.

*1) Up to max. 200°C fluid temperature with solenoid for higher temperature

*2) D.c. only, for a.c. solenoids with design inspection certificate acc.

to category 2, e. g. xxxxxx.8441

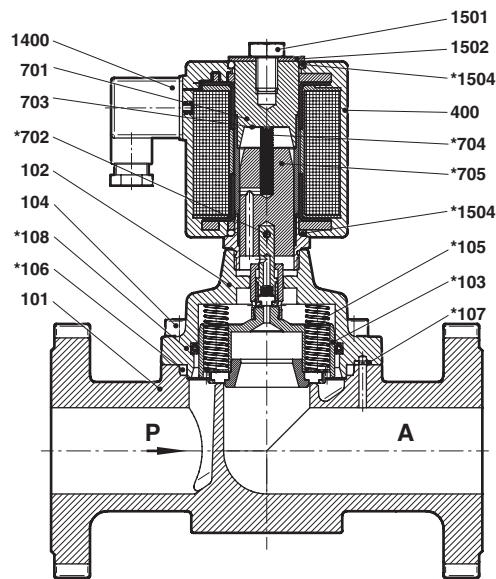
Section View
DN 15 ... 50

No.	Description
101	Valve body
102	Valve cover
*103	Valve piston
104	Socket head cap screw
*105	Pressure spring (from DN 32 2x)
*106	Gasket
*107	O-ring
*108	Grooved ring
400	Solenoid
701	Core tube
*702	Straight pin
703	Round plate
*704	Pressure spring
*705	Core
1400	Socket (included)
1501	Hexagon screw
1502	Round plate
*1504	O-Ring (2x)

* These individual parts form a complete wearing unit.
When ordering spare parts please state Model No. and Series No.

Dimensions

DN 15 ... 50

Dimensions in mm
Projection/First angle

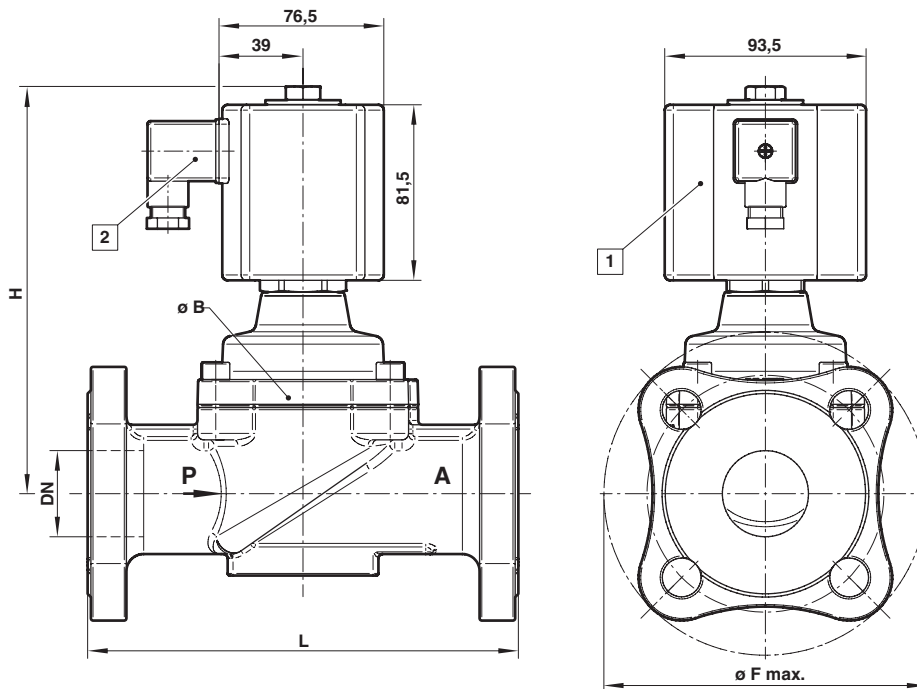
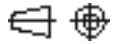

- 1 Solenoid rotatable 360°
- 2 Socket turnable 4 x 90°
(Socket included)

Orifice (mm)	ø B	ø F max.	H	L	Model
15	44	96	142	130	8558200.840x.xxxx
20	50	110	150	150	8558300.840x.xxxx
25	62	115	155	160	8558400.840x.xxxx
32	92	140	184	180	8558500.840x.xxxx
40	92	150	189	200	8558600.840x.xxxx
50	109	165	197	230	8558700.840x.xxxx

Contact face acc. to DIN EN 1092-1/B

Note to Pressure Equipment Directive (PED):

The valves of this series, including the connection size DN 25 (G 1), are according to Art. 3 § 3 of the Pressure Equipment Directive (PED) 97/23/EC. This means interpretation and production are in accordance to engineers practice well known in the member countries. The CE-sign at the valve refers not to the PED. Thus the declaration of conformity is not longer applicable for this directive.

For valves > DN 25 (G 1) Art. 3 § (7) No.1.4 applies

The basic requirements of the Enclosure I of the PED must be fulfilled. The CE-sign at the valve includes the PED. A certificate of conformity of this

directive will be available on request.

Note to Electromagnetic Compatibility (EMC):

The valves shall be provided with an electrical circuit which ensures the limits of the harmonised standards EN 61000-6-3 and EN 61000-6-1 are observed, and hence the requirements of the Electromagnetic Compatibility Guideline (2004/108/EC) satisfied.