

Operating instructions - Rotary pneumatic controller 8287354

Document-No. EN8287354BA Revision 4

Keep documentation for future use!

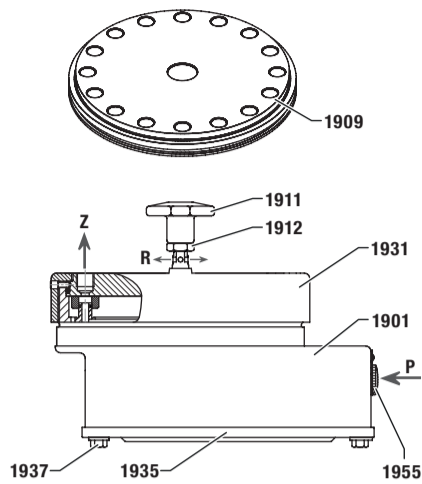

- 1911** Star knob
- 1912** Hexagon nut
- 1931** Screw piece
- 1901** Body
- 1955** Plug
- 1955** Body cover
- 1937** Tab screw (3x)
- 1909** Round plate (control disc)
- Z** Valve connections 16 x G 1/4
- R** Venting port
- P** Control port G 1/8

Ex II2 GD c IIB T85°C
Ex M2 c TÜV 04 ATEX 2606

Factory settings

Interval	adjustable 2 ... 200 seconds
factory setting	ca. 10 seconds
Pulse time	adjustable 30 ... 1.000 ms
factory setting	ca. 200 ms

1 About this documentation

This operation manual guides you to mount the rotary pneumatic controller, to commission, to maintain and to replace parts and assemblies.

1.1 Documentation validity

This operation manual applies to pneumatic controller 8287354.0000.00000 with sixteen valve connections.

This operation manual is intended for: distributor/operator, installers and service technicians.

1.2 Structure of safety instructions

Safety instructions warns against dangerous situations and must be observed in particular. Safety instructions are structured as follows:

SIGNAL WORD

Type of hazard

Consequences of non-observance

→ Precautions necessary to avoid the hazard

1.3 Hazard classes (ANSI Z535.6)

DANGER

Safety information indicates a hazardous situation with high risk which, if not avoided, will certainly result in death or (serious) injury.

WARNING

Safety information indicates a hazardous situation with moderate risk which, if not avoided, can cause death or severe injury.

CAUTION

Safety information indicates a hazardous situation on which, if not avoided, could result in minor or moderate injury.

NOTICE

Information indicates a hazardous situation which, if not avoided, could result damage to property.

1.4 Styles and symbols

•	list
→	instruction
1.	preset order of instructions
2.	
1911	part number (according to part list)
1	part number (document)

+ DANGER / WARNING / CAUTION;
NOTICE: embedded safety message

1.5 Intended use

The pneumatic controller is solely intended to control up to 16 dust filter cleaning valves.

The pneumatic controller must only be operated with fluids that do not damage its constituent materials.

Consult our applications engineers if you have doubts whether the pneumatic controller is suitable for the intended purpose in permanent operation.

The pneumatic controller is suitable for use in these areas:

- areas with potentially explosive mixtures of gases and air (zones 1 and 2), or of dust and air (zones 21 and 22). This includes Equipment Category 2 and 3.
- in underground parts of mines and parts of surface installations of mines.

The Ex marking on the rating plate shows the operating limits.

The pneumatic controller is suitable for Group II gases and corresponds to article 4 (3) of directive 2014/68/EU (pressure equipment device directive).

1.6 Improper use

In the following cases it is prohibited to operate the pneumatic controller:

- The pneumatic controller is used outside the permitted operating limits. The permitted temperature and pressure ranges are exceeded.
- Damages to the pneumatic controller – e.g. cracks, deformation – were detected but the pneumatic controller remains in operation.
- Malfunctions were detected but the pneumatic controller remains in operation.
- The pneumatic controller has been modified without authorization of the manufacturer.
- The safety instructions of this documentation are not observed.

1.7 Obligations of distributor/operator

- As distributor you are responsible that the pneumatic controller is mounted according to this operation manual. You are responsible that the operating limits are considered in designing the filter cleaning system.
- Ensure compliance with applicable laws, directives, regulations.

→ Ensure compliance with the following demands before persons mount, maintain or replace the pneumatic controller:

- This documentation must be fully read and understood.
- This documentation must be available at any time.
- Regulations about occupational safety and safety engineering must be known.

2 General safety instructions

These safety instructions are only related to the single pneumatic controller. In combination with other plant components there may be other potential dangers, which must be taken into account by carrying out a risk analysis for the system.

- Compare the details on the rating plate and the operating limits as shown in the datasheet to the operating data. The limits for the particular application must not be exceeded.

CAUTION

Injuries caused by moving parts

There is a danger of getting injured by moving parts, while the body cover is opened.

- Depressurize the plant/system prior to open body cover.

Residual risks

	Weight of the pneumatic controller Phases: transport, storage, assembly, maintenance, disposal Risk: falling off, tipping over Personal protection equipment (PPE): Protective footwear
	Sharp threads and edges Phases: transport, assembly, maintenance, disposal Risk: Risk of cuts PPE: Protective gloves

3 Avoid damage to property

NOTICE

Damages through mechanical loads

The pneumatic controller may get damaged by external loads at the operating site.

- Protect the pneumatic controller from possible impact load.
- Secure the pneumatic controller against direct weather influences and the possible effects.

4 Identifying pneumatic controller

The rating plate is situated on the body of the pneumatic controller.

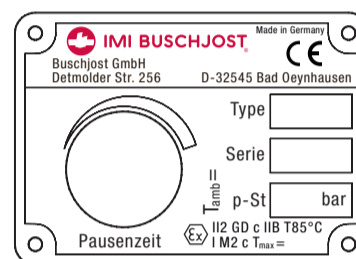

Rating plate (master)

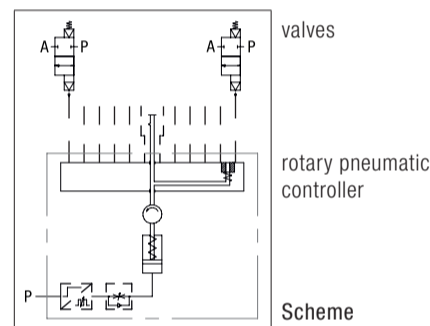

5 Transport and storage

- Only transport and store the pneumatic controller in its delivery packaging.
- Avoid mechanical loads: falling off, tipping.

6 Principle of operation

Design

Pneumatic controller with ratchet drive, employing pneumatic cylinder with return spring and interval controlled by pneumatic timer.

Throttle valve in pneumatic cylinder for speed of operating stroke (switching time of valve connection Z).

Operation

The unit is used for cyclical control of indirectly actuated valves with pilot pressure venting connection.

The pressure chamber of the pneumatic controller is pressurized via the valves' internal pilot ports and their pilot lines Z. Then the number of valves that are connected to the pressure chamber are closed.

The pressurization of the control port P causes the pneumatic cylinder to perform an idle stroke, and allows the pawl of the ratchet drive to engage one segment further on.

After the interval, the compression spring fitted in the cylinder produces an operating stroke. This moves the wiper arm 1907 over a valve connection Z. During this time the valve connected opens and closes again. This cycle is repeated as long as there is pressure at the control port P.

Manual override knob

The star knob 1911 can be used to switch the controller onwards manually during operation or when idle.

The mark on the star knob shows the position of the wiper arm.

7 Mounting

7.1 Ensure potential equalisation

The ground connection can be realized by mounting the unit directly at conducting parts of the system by using the lateral thread holes of the body 1901 of the pneumatic controller.

Also it is possible to connect an earth wire with a minimum wire cross section of 4 mm² there. The earth wire must be protected against corrosion, torsion and self-untightening to provide a permanent contact.

Special precautions must be taken if any contacted part is made of light metal. Use for example a steel-spacer.

7.2 Mount pneumatic controller

The pneumatic controller can be mounted in any position.

- Make sure that there is enough free space for dismantling the pneumatic controller in case of maintenance.
- **NOTICE** The step-by-step rotation moving of the star knob 1911 must not be interrupted by the laid pilot lines.
- **NOTICE** Take care that the position of the round plate 1909 will not change while mounting fittings at the pilot connectors Z.
- To achieve identical valve switching times, if possible use lines of identical length to connect them to Z.
- Unused valve connections Z must be sealed with threaded plugs.

7.3 Adjust switching time and interval

The switching time of the valves connected can be adjusted with the throttle valve fitted in the cylinder (beneath body cover).

- Screwing in throttle valve screw increases the switching time
- Unscrewing throttle valve screw decreases the switching time

This adjustment can only be carried out after removing the cover 1935. **CAUTION** There is a danger of getting injured by moving parts. Depressurize the plant/system prior to open body cover.

The interval can be adjusted on the outside of the timer, using the screw behind the plug 1955 in the name plate.

8 Operating conditions

Pressure range	0.5 to 8 bar
Control pressure	2 to 8 bar
Fluid temperature	0°C to +70°C
	-25°C bis +70°C for dry air
Ambient temperature	0°C to +40°C
Control pressure supply (port P):	Compressed air, filtered with pore size 5 to 10 µ, not lubricated.
Operating fluid (valve connections Z):	contaminated compressed air

NOTICE Avoid significant pressure fluctuations – the interval of the pneumatic controller depends on the control pressure.

- reduction in pressure = shortening of interval
- increase in pressure = lengthening of interval

9 Commissioning

- **CAUTION** Ensure before commissioning that initial electrical actuation cannot give rise to danger from fluid escaping from unsecured openings. Prime the valve slowly when commissioning. The control chamber of the controller must reach operating pressure level before availability.

CAUTION Any surge in pressure will cause the opening of all connected valves.

- **WARNING** In explosive atmosphere the device must be connected to the system's earth wire.

- **WARNING** After adjusting the interval the hole at the rating plate must be closed with the plug to preserve the ex-dust protection.



