

Installation & Maintenance Instruction

VR10 / VR15

Valve Islands

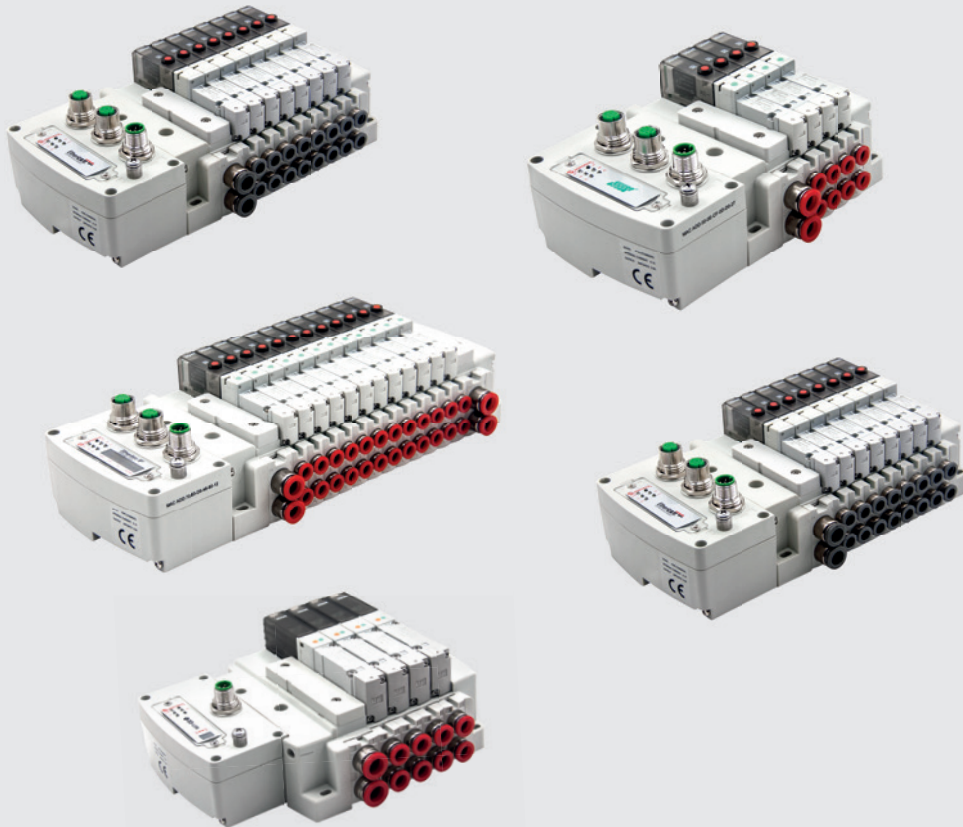

EtherNet/IP™



Before starting work read these instructions.

This manual contains proprietary information. No part of this publication may be reproduced, transcribed or transmitted in any form without the written consent of the publisher. Every effort has been made to ensure that the information contained in this manual is accurate. All rights reserved.

Change history:

The change history reflects all changes of the Installation & Maintenance Instruction, which were done after the initial release.

Index	Chapters	Change description	Date	Name
001	All	New release	27-Nov-2020	GG
002	All	Minor changes about pictures and texts, add ISEM & External Pilot Base Fittings disassembly/assembly.	27-Jan-2021	GG
003	4	Additional minor comments implemented	4-Feb-2021	GG
004	4	Minor changes about tie rods	18-Feb-2021	GG
005	All	Minor changes to text	23-Mar-21	RL

This Installation & Maintenance Instruction makes no claims of being complete as it does not cover all variants of the VR10 / VR15 valve islands.

Therefore, this document is subject to extensions or changes.

1 CONTENTS

1	CONTENTS	3
2	VR10 / VR15 OVERVIEW	5
3	SAFETY, WARNINGS	8
4	INSTALLATION AND MAINTENANCE	9
4.1	INSTALLATION AND OPERATION	9
4.1.1	Overview	9
4.1.2	Tools	10
4.1.3	Tightening Torque	10
4.1.4	Port Identification	10
4.1.5	Manual Override Operation	11
4.1.6	Assembling and Disassembling	12
4.1.7	Piping	33
4.1.8	Multi-Pressure Zone Option	34
4.2	MAINTENANCE	35
4.2.1	Lubrication	35
4.2.2	Valve Identification Information	35
4.2.3	Spare Parts	35
5	TRANSPORT / STORAGE / PACKAGING	35
6	TECHNICAL DATA	36
6.1	SPECIFICATION	36
6.1.1	Operation	36
6.1.2	Flow Rate	36
6.1.3	Valve Mounting	36
6.1.4	Ambient Temperature	36
6.1.5	Medium Temperature	36
6.1.6	Medium	37
6.1.7	Air Quality	37
6.2	MATERIALS	37
6.3	PNEUMATIC	38

Construction & Design is subject to change (A1743-OPM-MX / Rev.004)

6.3.1	Response Time	38
6.3.2	Push in Fitting	38
6.3.3	Valve Function	38
6.3.4	Life Expectation.....	39
6.4	ELECTRICAL.....	40
6.4.1	General Features for Valve Island with Protocols	40
6.4.2	General Features for Valve Island with Multipole D-Sub Connector.....	41
6.4.3	Wiring Rules for Multipole Series	42
6.4.4	Pin Allocating & Wire Colours Identifying for Multipole Series	45
6.4.5	Wire Connection for Valve Island with Protocols	47
6.5	COMPLIANCE AND APPROVALS.....	51
6.5.1	CE marking	51
6.5.2	REACH.....	51
6.5.3	RoHS.....	51
7	CUSTOMER SUPPORT	52

Construction & Design is subject to change (A1743-OPM-MX / Rev.004)

Note: All images shown in this document are indicative only. If there is any inconsistency between the images and the actual product, the actual product shall govern.

2 VR10 / VR15 OVERVIEW

- Valve width: VR10: 10mm VR15: 15mm
- Valve Polarity:
 - Valve island with multipole D-Sub Connector 25-Pin:
 - 24 VDC system: Common Negative (PNP) & common Positive (NPN)
 - 12 VDC system: Common Negative (PNP)
 - Valve island with protocols:
 - Common Negative (PNP) with 24 VDC only
- Up to 24 solenoids
- LED indication of solenoid function
- Ingress Protection:
 - IP40
 - IP65
- Expansible station with extension kit
- Easy to replace valves and fittings
- DIN Rail and base mounting options
- Modular system with a wide range of configurations

- To configure and order a Valve Island, visit <https://www.norgren.com>

Construction & Design is subject to change (A1743-OPM-MX / Rev.004)

Installation & Maintenance Instruction

VR10 / VR15 VALVE ISLAND



Easy to identify operation with LEDs next to solenoids. Solenoid A (14 Solenoid) turns on red LED, and Solenoid B (12 Solenoid) turns on green LED.

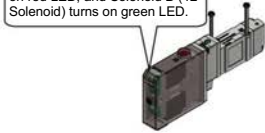

Easy to replace sub-base, with click together circuit boards for electrical connectivity.

Double and single wiring determined by circuit board.

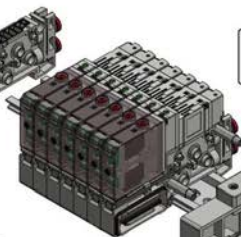

Possible to select silencer or blanking

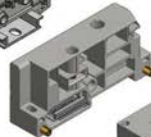

Industrial universal Electrical Interface D-Sub Connector 25-Pin IP40 version



Vertical or Horizontal D-Sub Connector easier installation



Vertical

Horizontal

Excellent interchangeability of control module

EtherCAT



IO-Link



Multipole (IP65 Version) D-Sub Connector 25-Pin



Construction & Design is subject to change (A1743-OPM-MX / Rev.004)

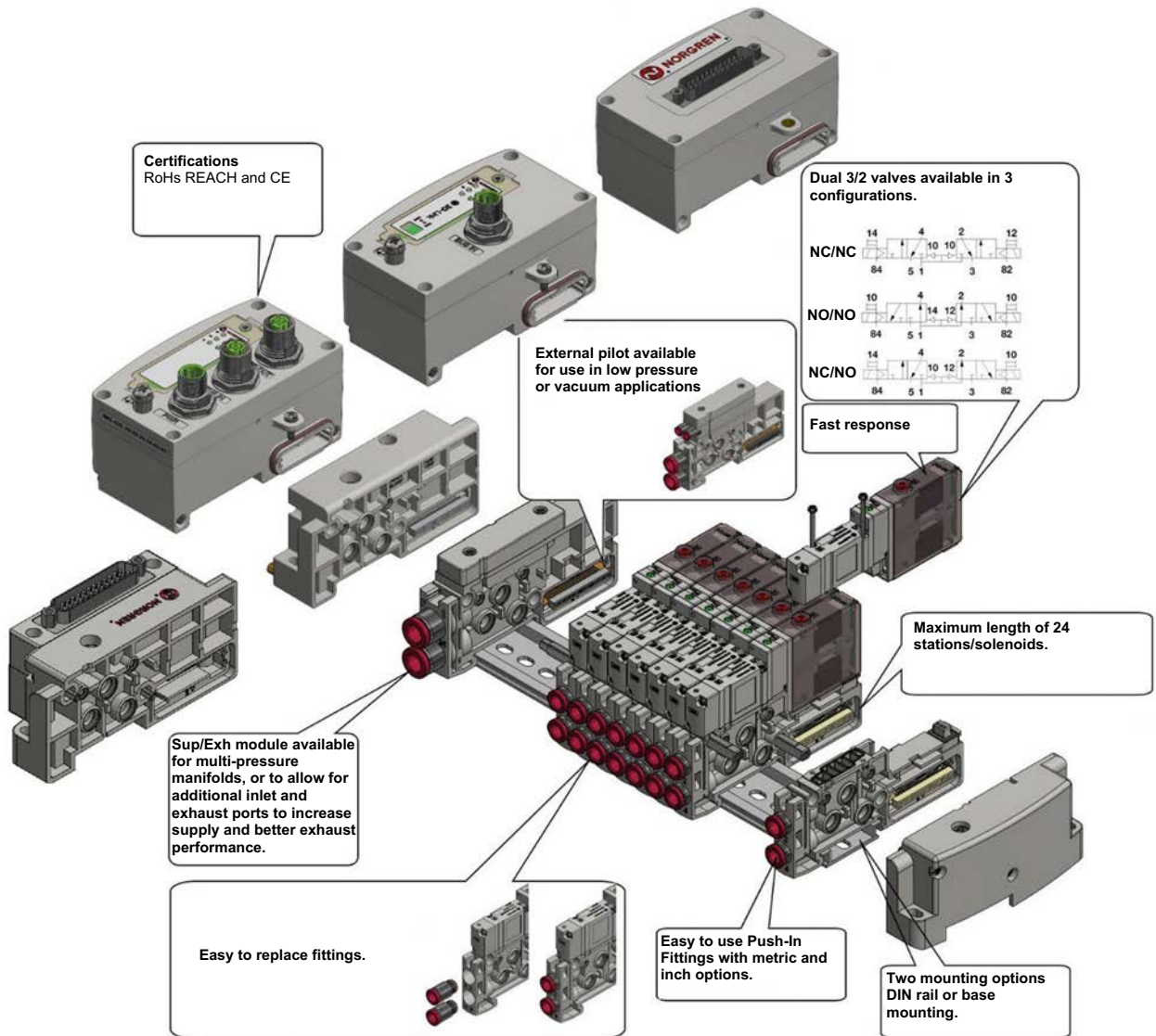

Construction & Design is subject to change (A1743-OPM-MX / Rev.004)

3 SAFETY, WARNINGS

This product is intended for use in industrial compressed air system only. Do not use this product where pressures and temperatures can exceed those under 'Technical Data'.

Before using this product with fluids other than those specified, for non-industrial applications, life-support systems, or other applications not within published specifications, consult IMI Norgren. Through misuse, age, or malfunction, components used in fluid power systems can fail in various modes. The system designer is warned to consider the failure modes of all component parts used in fluid power systems and to provide adequate safeguards to prevent personal injury or damage to equipment in the event of such failure.

System designers must provide a warning to end users in the system instructional manual if protection against a failure mode cannot be adequately provided. System designers and end users are cautioned to review specification warnings found in instruction sheets packed and shipped with this product.

Specific warnings:

- Check that the specification of the Valve Island and marking on the item of the equipment are suitable for the application it is being used on.
- Check technical data, such as operating pressure, voltage level, current and temperature, on the product label or in the data sheets for compliance with the existing operating conditions.
- After removing the packaging, ensure that no contamination enters the system.
- Check before the installation of the system that no contamination exists in the piping and valve island.
- Check during installation of the system that gaskets have not become damaged.
- Take measures to avoid unintentional or improper activation.
- Prior to the first electrical operation, ensure no danger would result from the medium exhausting from any open ports.
- Consider in case of pressurised systems that lines, valves and other components should not be removed.
- To avoid damaging the product, please make sure that the maximum torque values are not exceeded.
- **IMPORTANT:** Always switch off the air supply, exhaust the residual pressure and unplug all electrical connections before performing any maintenance.
- Ensure the machine is in a safe condition before operating manual overrides.
- Pay due care and attention to the different polarity types available - PNP/NPN.
- A polarity protection diode is built in: Incorrect polarity does not cause a short circuit and does not require replacement valve slices. In this case only the LED indicator works, but not the valve slices.

4 INSTALLATION AND MAINTENANCE

4.1 INSTALLATION AND OPERATION

4.1.1 Overview

- DIN Rail is optional depending on your requirement.
- 2-10 stations: one Sup/Exh (supply/exhaust) Module is required.
- 11-24 stations: two Sup/Exh Modules are recommended.

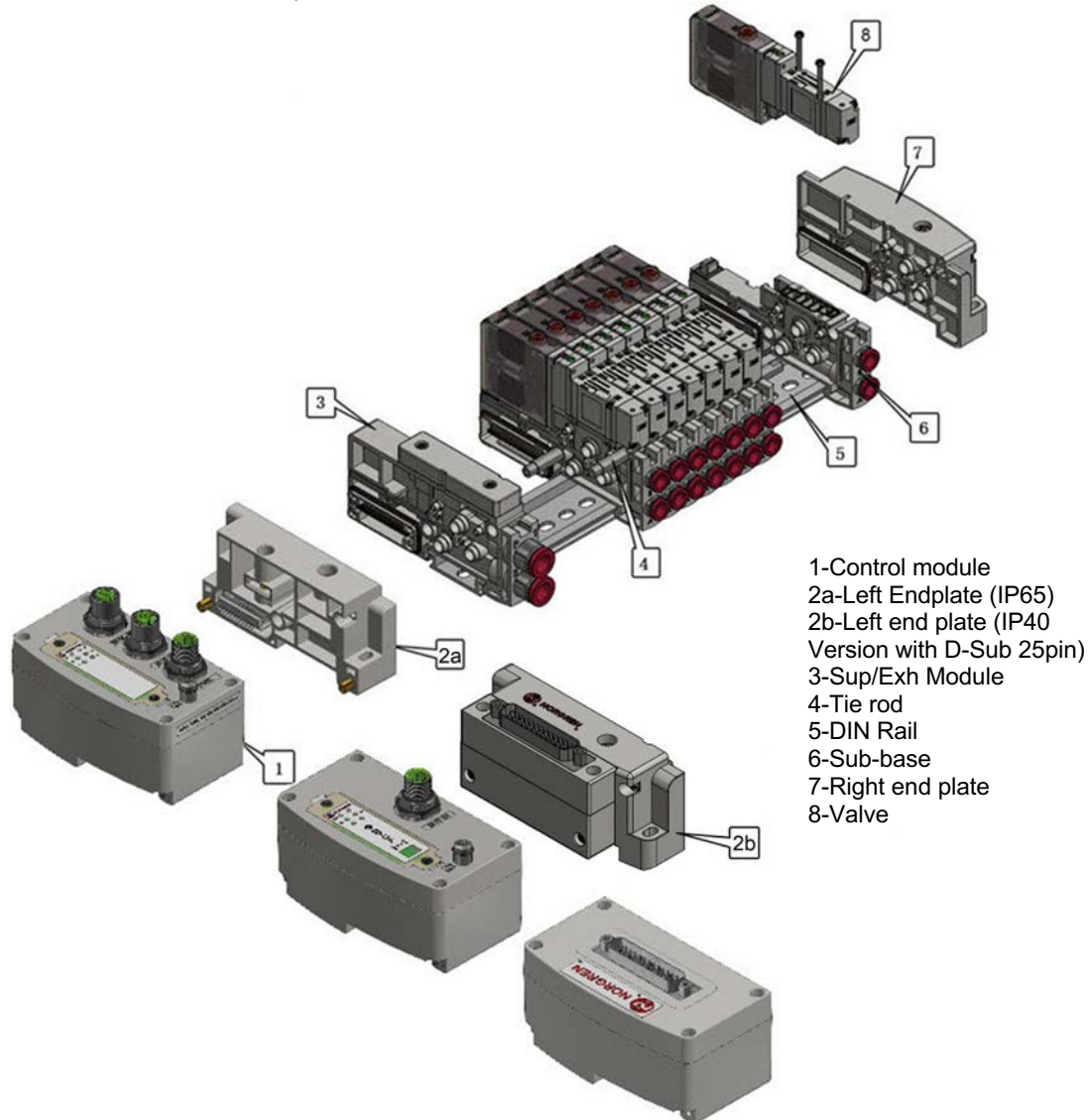

Construction & Design is subject to change (A1743-OPM-MX / Rev.004)

4.1.2 Tools

VR10:

- Phillips screwdriver size #00
- Phillips screwdriver size #1
- Phillips screwdriver size #2
- Slotted screwdriver 3mm

VR15:

- Phillips screwdriver size #1
- Phillips screwdriver size #2
- Slotted screwdriver 3mm

4.1.3 Tightening Torque

To avoid damaging the product, please follow recommended torque values.

- M2 screws, torque at 0.15~0.2 Nm (1.3~1.8 lbf·in)
- M3 screws, torque at 0.4~0.5 Nm (3.5~4.4 lbf·in)
- M4 screws, torque at 0.7~0.8 Nm (6.2~7.1 lbf·in)

4.1.4 Port Identification

Port Description	Port Identification
Port for Main & internal pilot air supply	P / 1
Port for air exhaust	E / 3 / 5
Port for air outlet	A / 4 & B / 2
Port for external pilot air supply (if used)	12 / 14
Port for collected air exhaust of pilot valves	82 / 84

Note:

Do not plug port 3/5 or 82/84 if the silencer is not incorporated into Sup/Exh Module.

Plugging either port will cause valves to malfunction.

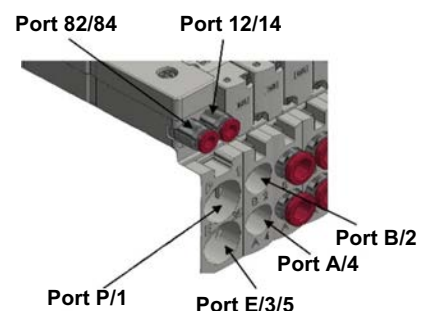

Construction & Design is subject to change (A1743-OPM-MX / Rev.004)

4.1.5 Manual Override Operation

VR10:

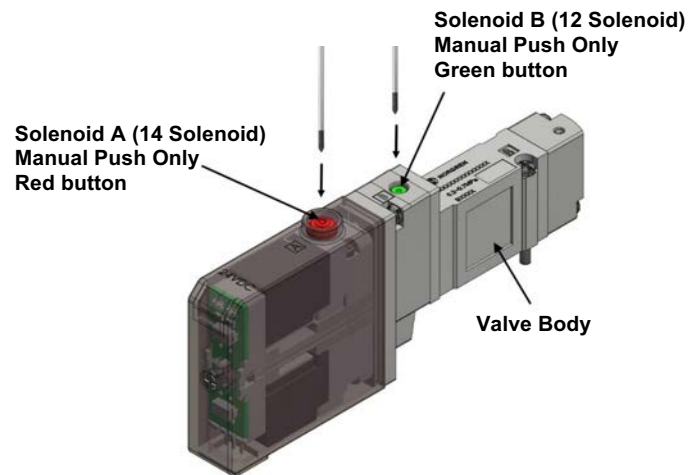

VR15:

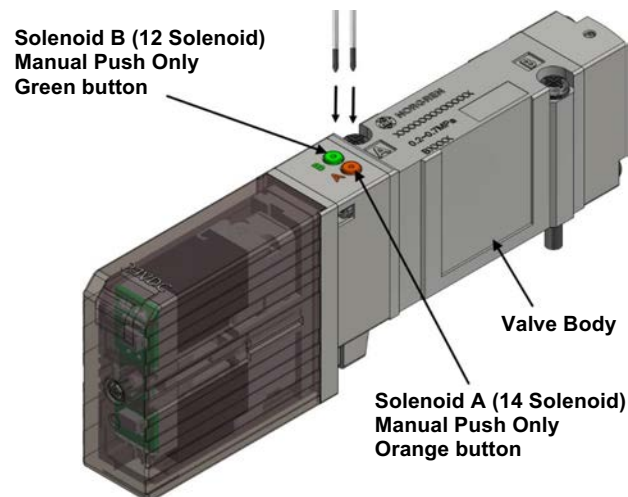

Construction & Design is subject to change (A1743-OPM-MX / Rev.004)

4.1.6 Assembling and Disassembling

IMPORTANT:

Pressure and power must be removed from system before assembling & disassembling electrical connectors, cables, plugs, valves, and blanking plates.

4.1.6.1 Torque List and Its Location

- IP65 Valve Island

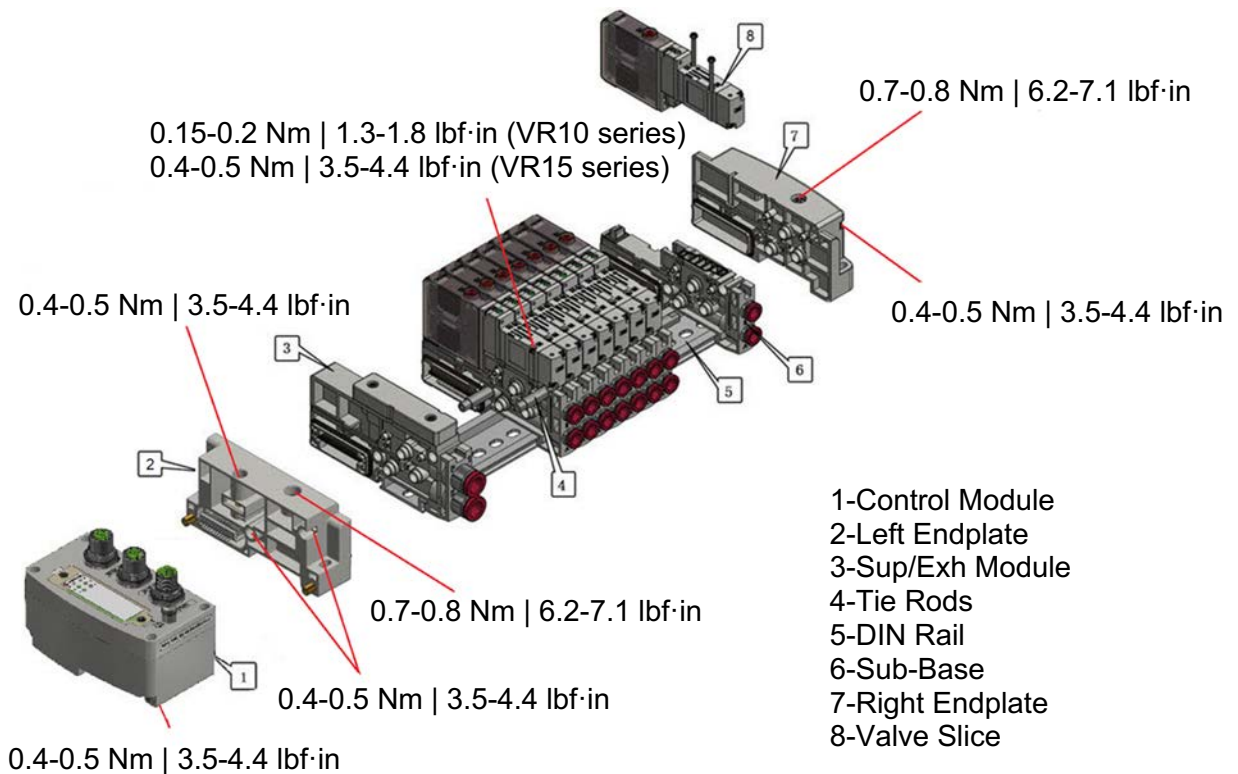

Construction & Design is subject to change (A1743-OPM-MX / Rev.004)

- IP40 Valve Island

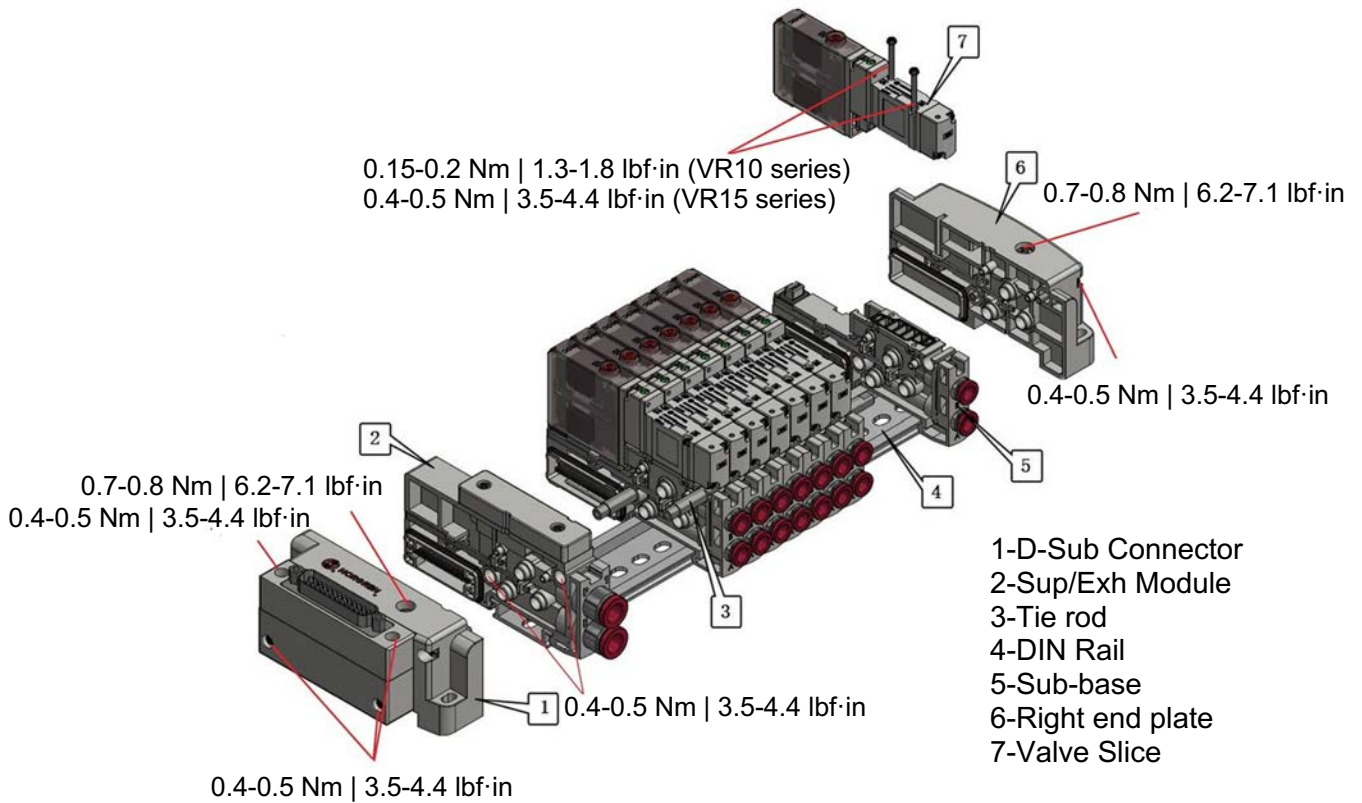

Construction & Design is subject to change (A1743-OPM-MX / Rev.004)

4.1.6.2 Assembling and Disassembling Control Module (IP65 Version)

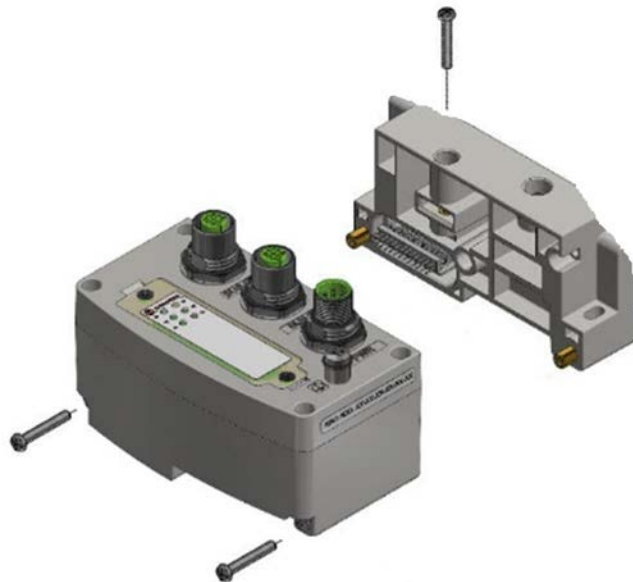

- Disassemble control module
 - 1) Disassemble all three screws on control module.
 - 2) Pull out control module
- Assemble control module
 - 1) Push in control module
 - 2) Assemble all three screws on control module.

Construction & Design is subject to change (A1743-OPM-MX / Rev.004)

4.1.6.3 Changing Orientation of D-Sub Connector (IP40 Version)

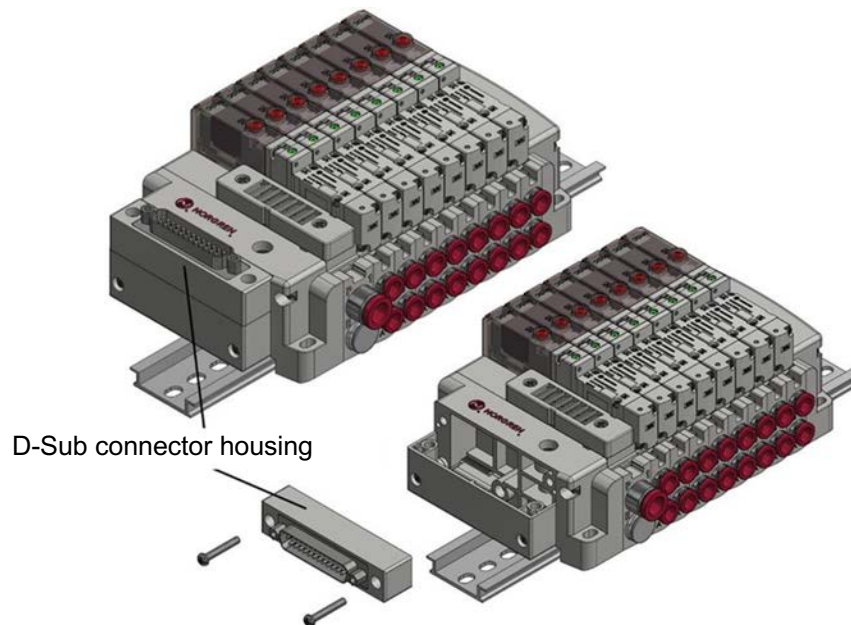

- Disassemble D-Sub connector housing
 1. Disassemble two screws on D-Sub connector housing
 2. Pull out D-Sub connector housing slowly and make sure the wires are not damaged. (Wires are not shown)
- Change the orientation as required.
- Assemble D-Sub connector housing
 1. Push and hold D-Sub connector housing to left endplate
 2. Assemble two screws on left endplate

Construction & Design is subject to change (A1743-OPM-MX / Rev.004)

4.1.6.4 Assembling and Disassembling D-Sub Connector (IP40 Version)

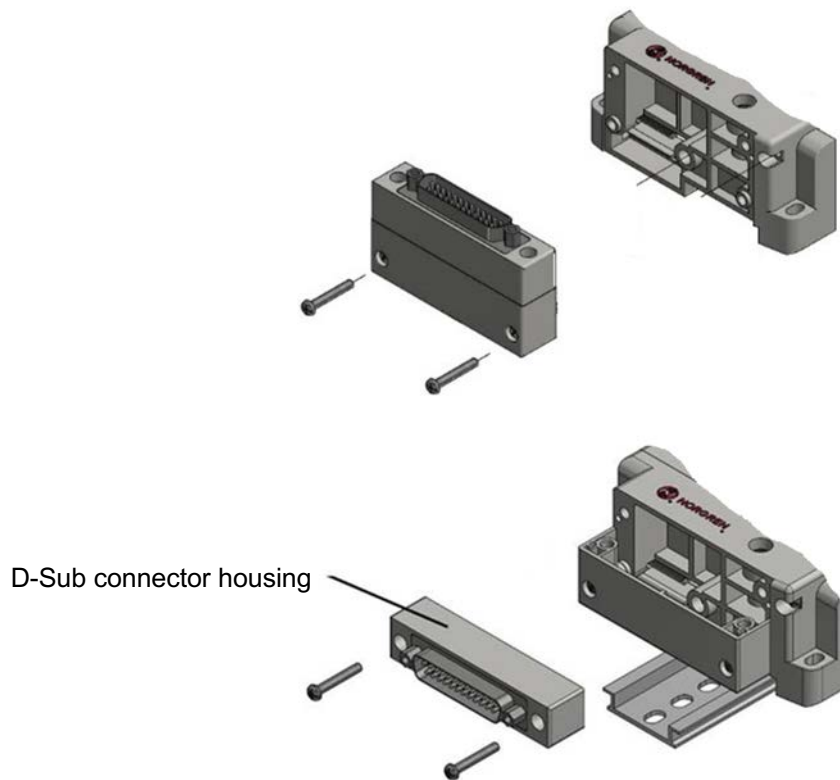

- Disassembling D-Sub connector
 1. Disassemble two screws on D-Sub connector
 2. Pull out D-Sub connector slowly. Make sure the connector is in its place.
 3. Loosen the screw on the D-Sub connector housing if orientation is horizontal.
 4. Pull out D-Sub connector housing slowly and make sure the wires are not damaged. (Wires are not shown)

- Assembling D-Sub connector
 1. Push and hold D-Sub connector to left endplate. Make sure the wires are proper placed.
 2. Assemble two screws with correct torque.
 3. Push and hold D-Sub connector housing to left endplate
 4. Assemble two screws on left endplate

Construction & Design is subject to change (A1743-OPM-MX / Rev.004)

IMPORTANT:

1. The red wire must be connected to the upper position as shown below.

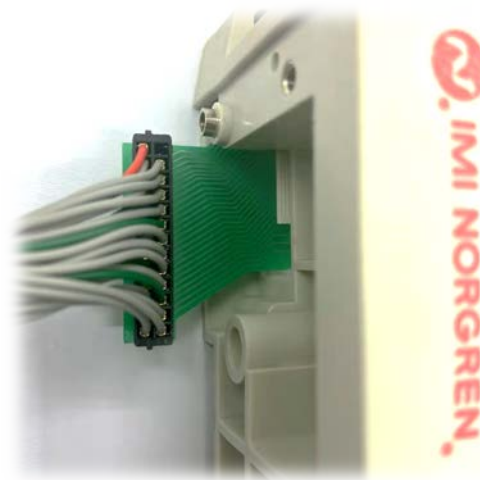

2. The PCB fitted must be located into the slot of the cover when assembling D-Sub connector.



Construction & Design is subject to change (A1743-OPM-MX / Rev.004)

4.1.6.5 Assembling and Disassembling Manifold

▪ Disassembling Manifold

Valve manifold can be disassembled after control module / D-Sub connector is removed.

1. Disassemble tie rod screws on left endplate.
2. Lift latch on right endplate.
3. Pull out right endplate and tie rods.
4. Disassemble tie rod screw on right end plate.
5. Lift latch on Sup/Exh module.
6. Pull out left endplate.

See illustration below.

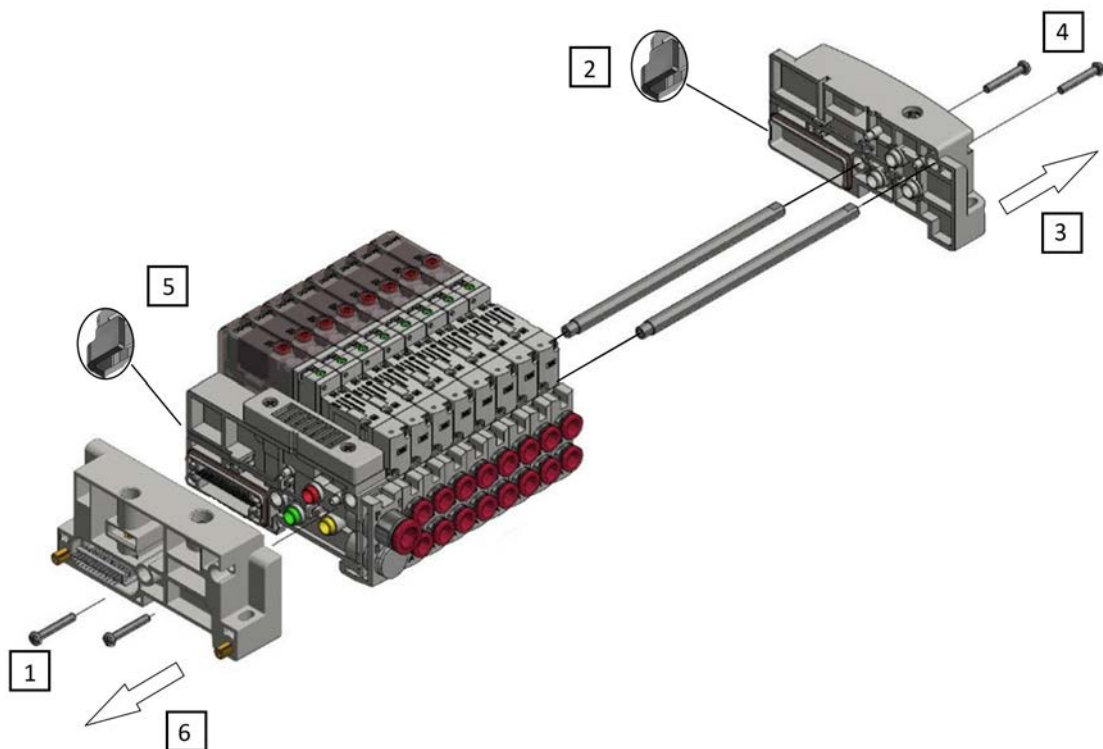

Construction & Design is subject to change (A1743-OPM-MX / Rev.004)

■ Assembly Manifold (right endplates as example)

1. Put flat end side of tie rods into right endplate, then attach screws to tie rods.
 2. Insert tie rods into valve stations and push to close the gap.
 3. Close the latch on right endplate.
 4. Push in left endplate. (See Note).
 5. Close all latches.
 6. Assemble tie rod screws on left endplate and apply torque.
- See illustration below.

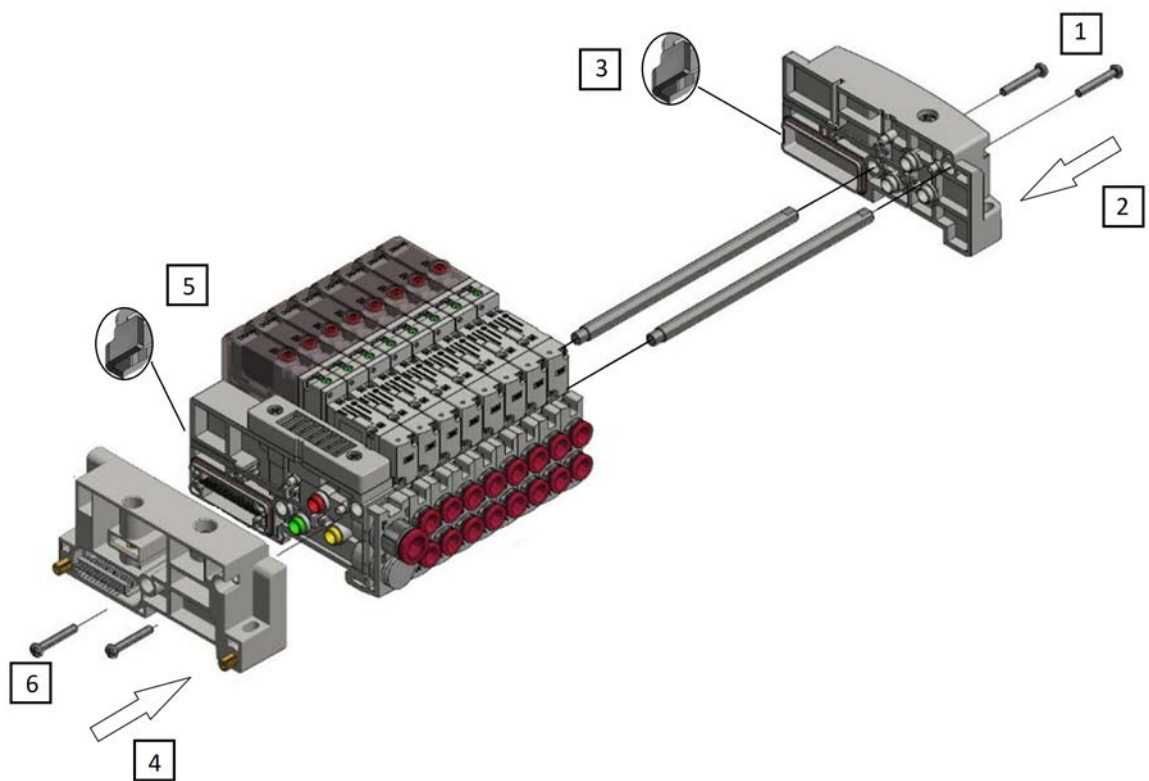

Note:
Remove this gasket
for IP40 version
before Step 4.

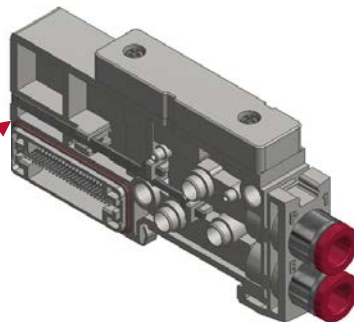

Construction & Design is subject to change (A1743-OPM-MX / Rev.004)

Note:
Expansion tie rod kits should be
assembled to the round side and any
gaps closed before inserting into valve
stations.

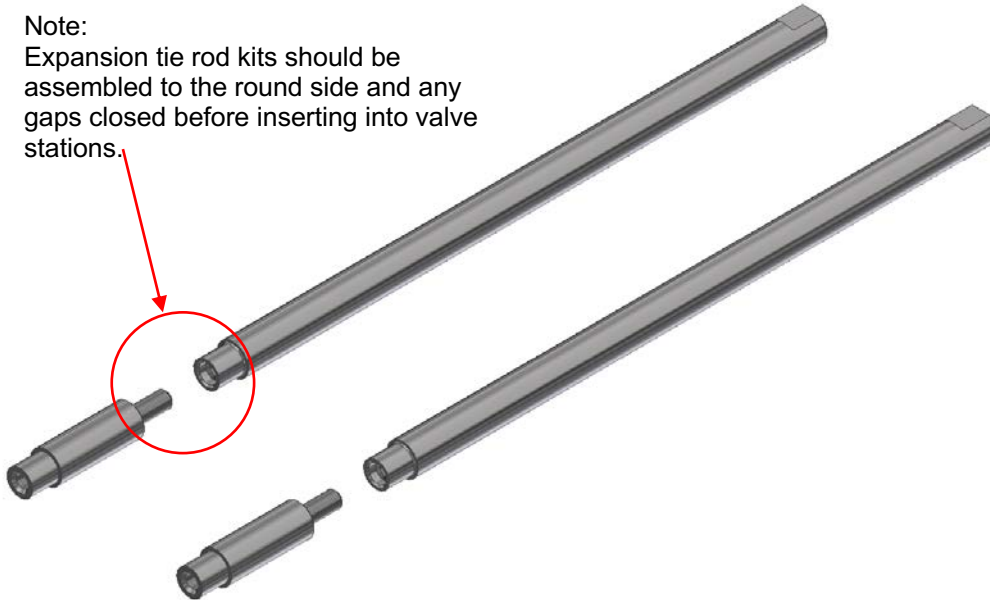

Construction & Design is subject to change (A1743-OPM-MX / Rev.004)

4.1.6.6 Assembling and Disassembling Sub-base or Sup/Exh Module (ISEM)

After endplates and tie rods been removed, the sub-base and ISEM can be disassembled by following steps.

- Disassembly

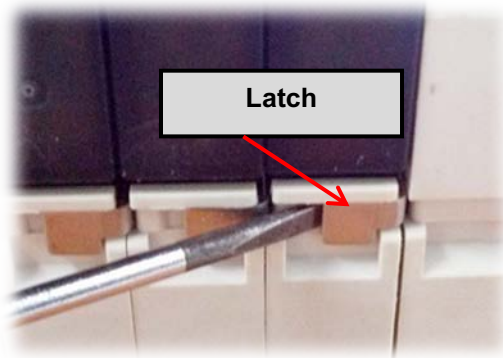

1) Put a slotted screwdriver into the gap of sub-base & latch.



2) Lift latch slowly until mechanical stop is detected.



3) Remove the parts.

Construction & Design is subject to change (A1743-OPM-MX / Rev.004)

▪ Assembly

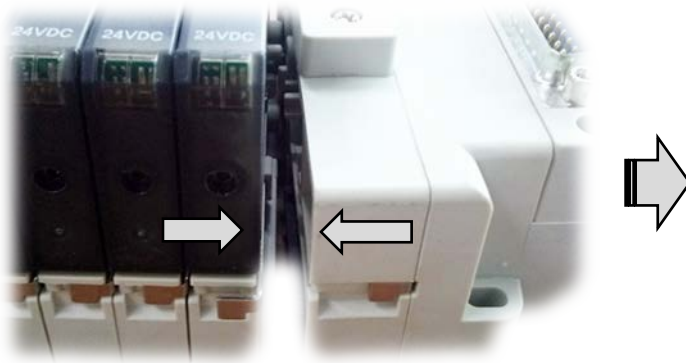

1) Push parts to close gaps.

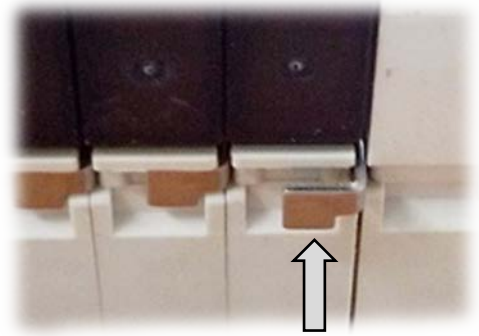

2) Push to close the latch.

In case of adding valve stations or ISEM, tie rod expansion kits are available as below:

Part number: VR**7516MM07##NA.

* *: - Insert 10 for VR10; or 15 for VR15.

##: - Insert MS: ISEM expansion rod

M1: 1 Station modular rod

M2: 2 Stations modular rod

Construction & Design is subject to change (A1743-OPM-MX / Rev.004)

4.1.6.7 Assembling and Disassembling Valve Slices

- Disassembling Valve Slice

1. Remove 2 screws on valve body by using a Phillips screwdriver.

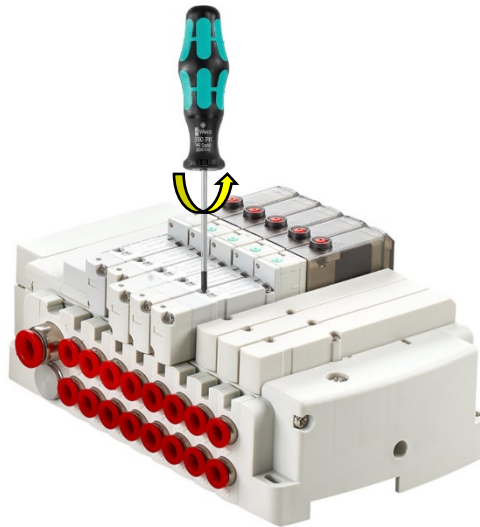

2. Lift the valve which will be replaced.



Construction & Design is subject to change (A1743-OPM-MX / Rev.004)

▪ Assemble Valve Slice

1. Drop the valve into its position and insert tab correctly. See view A.

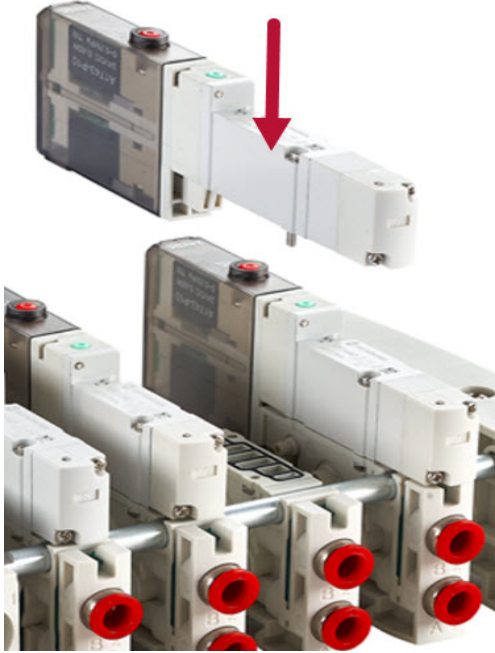

VIEW A

2. Tighten 2 screws with correct torque lock the valve onto sub-base.

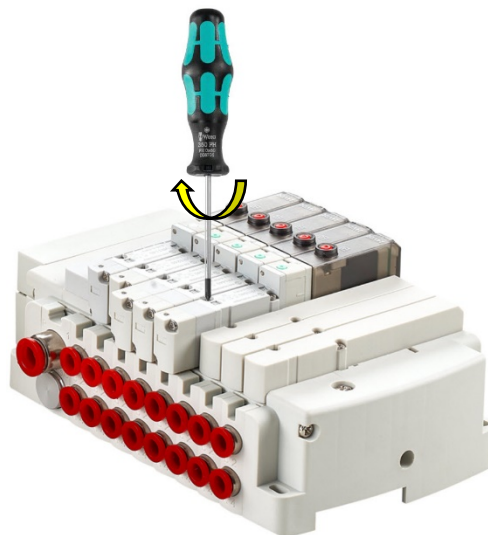

Construction & Design is subject to change (A1743-OPM-MX / Rev.004)

4.1.6.8 Assembling and Disassembling Fittings

ATTENTION:

Make sure air pressure is released before unlocking the locking pins.
Make sure the locking pin is properly installed before applying air pressure.

- VR10 Fitting Disassembly
 1. Lift locking pin with tool such as slotted screwdriver slowly to unlock position.
 2. Pull the fittings out by using a piece of inserted tube or other means.Note: In case of 5/3 valve, remove the valve before replacing fittings.

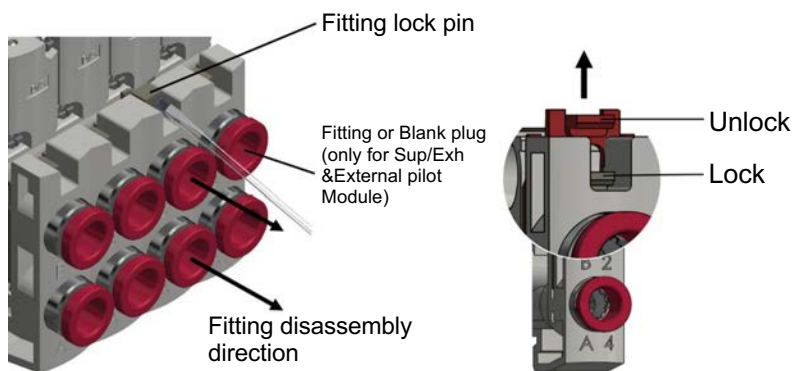

- VR10 Fitting Assembly
 1. Push the fitting into the port until it hits the bottom position.
 2. Press locking pin to its bottom position to lock the fittings.

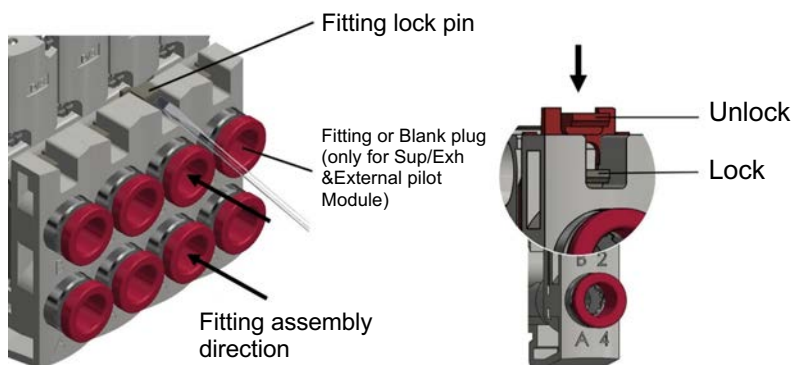

Construction & Design is subject to change (A1743-OPM-MX / Rev.004)

■ VR15 Fitting Disassembly

1. Lift fitting lock clips with tool such as slotted screwdriver slowly to unlock position.
2. Pull the fittings out by using a piece of inserted tube or other means.

Note: In case of 5/3 valve, remove the valve before replacing fittings.

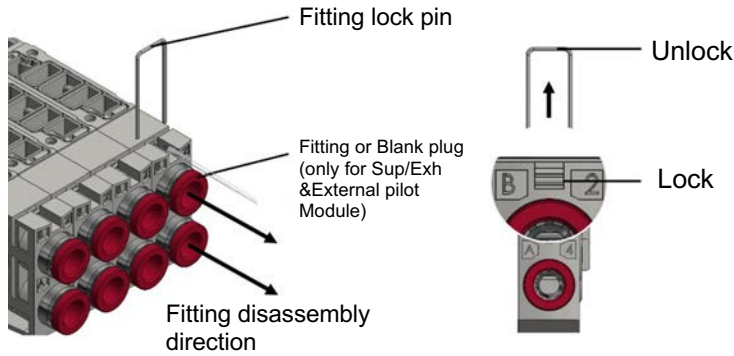

■ VR15 Fitting Assembly

1. Push the fitting into the port until it hits the bottom position.
2. Press locking pin to its bottom position to lock the fittings.

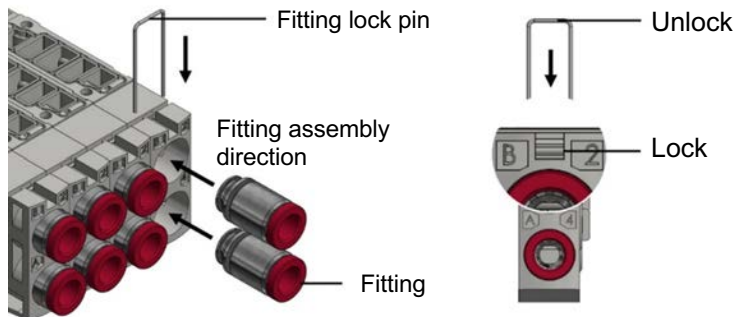

■ ISEM Fitting Disassembly

1. Lift fitting lock clips with tool such as slotted screwdriver slowly to unlock position.
2. Pull the fittings out by using a piece of inserted tube or other means.

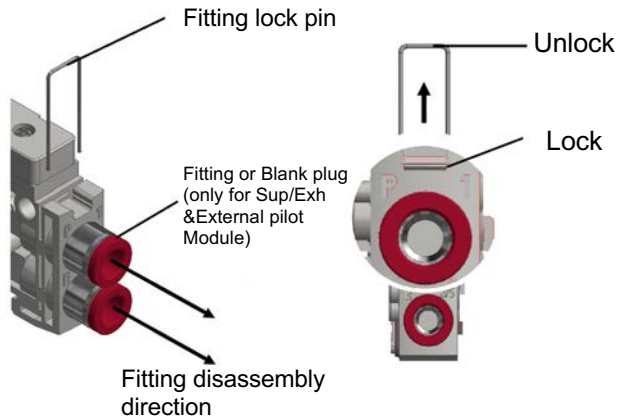

■ ISEM Fitting Assembly

1. Push the fitting into the port until it hits the bottom position.
2. Press locking pin to its bottom position to lock the fittings.

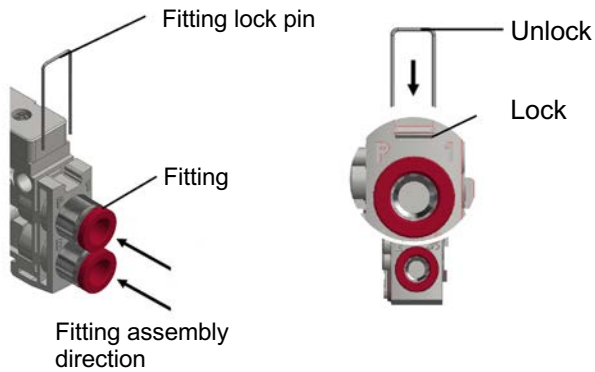

Construction & Design is subject to change (A1743-OPM-MX / Rev.004)

External Pilot Base Fitting Disassembly

1. Loosen the screw and remove external pilot base.
2. Remove locking pin by pushing a flat bladed screwdriver into the hole on the underside of the external pilot block.
3. Pull out the fitting or blank plug.

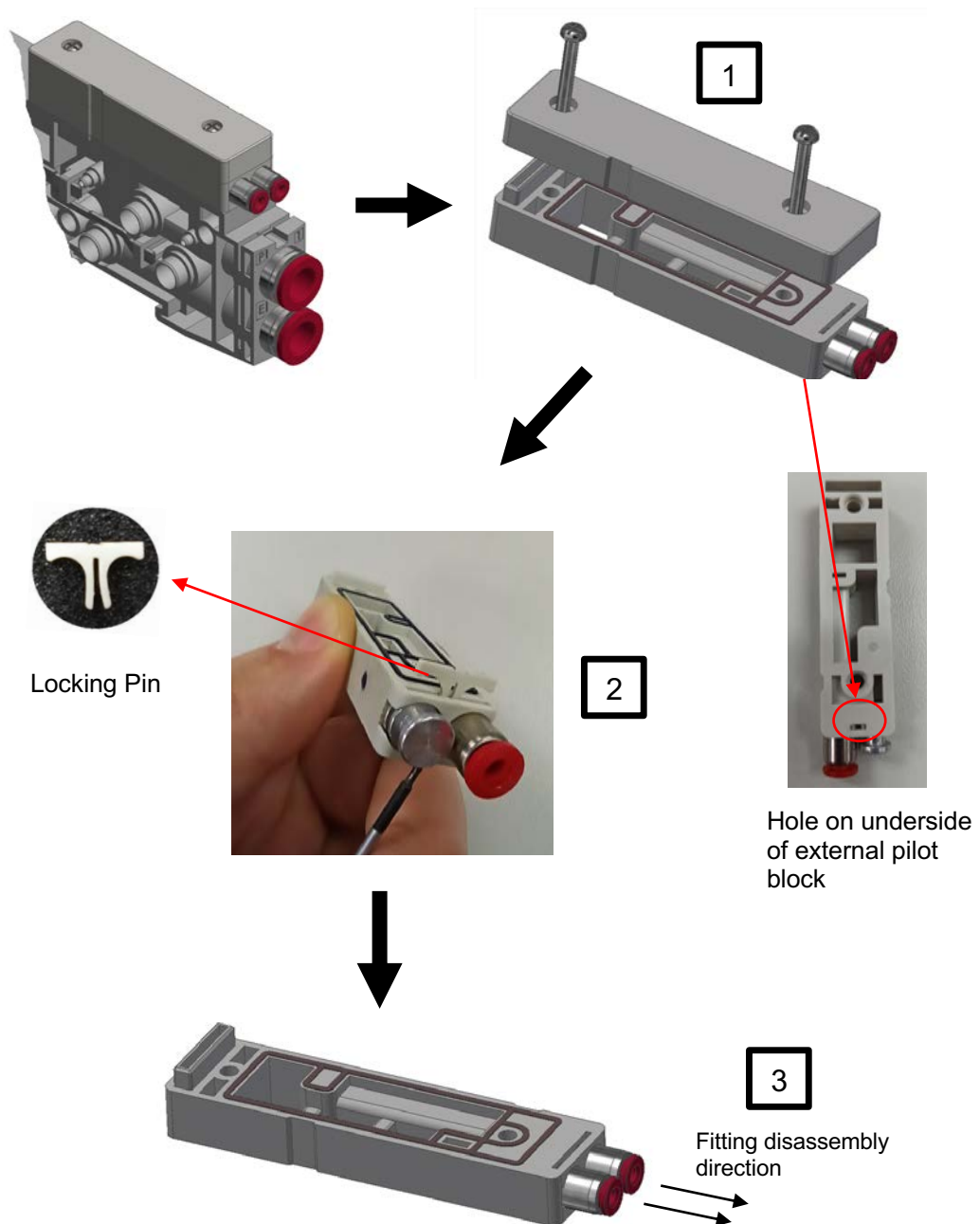

Construction & Design is subject to change (A1743-OPM-MX / Rev.004)

External Pilot Base Fitting Assembly

1. Push the fitting into the port until it hits the bottom position.
2. Press locking pin to its bottom position to lock the fittings.
3. Assemble the external pilot base and tighten the screw.

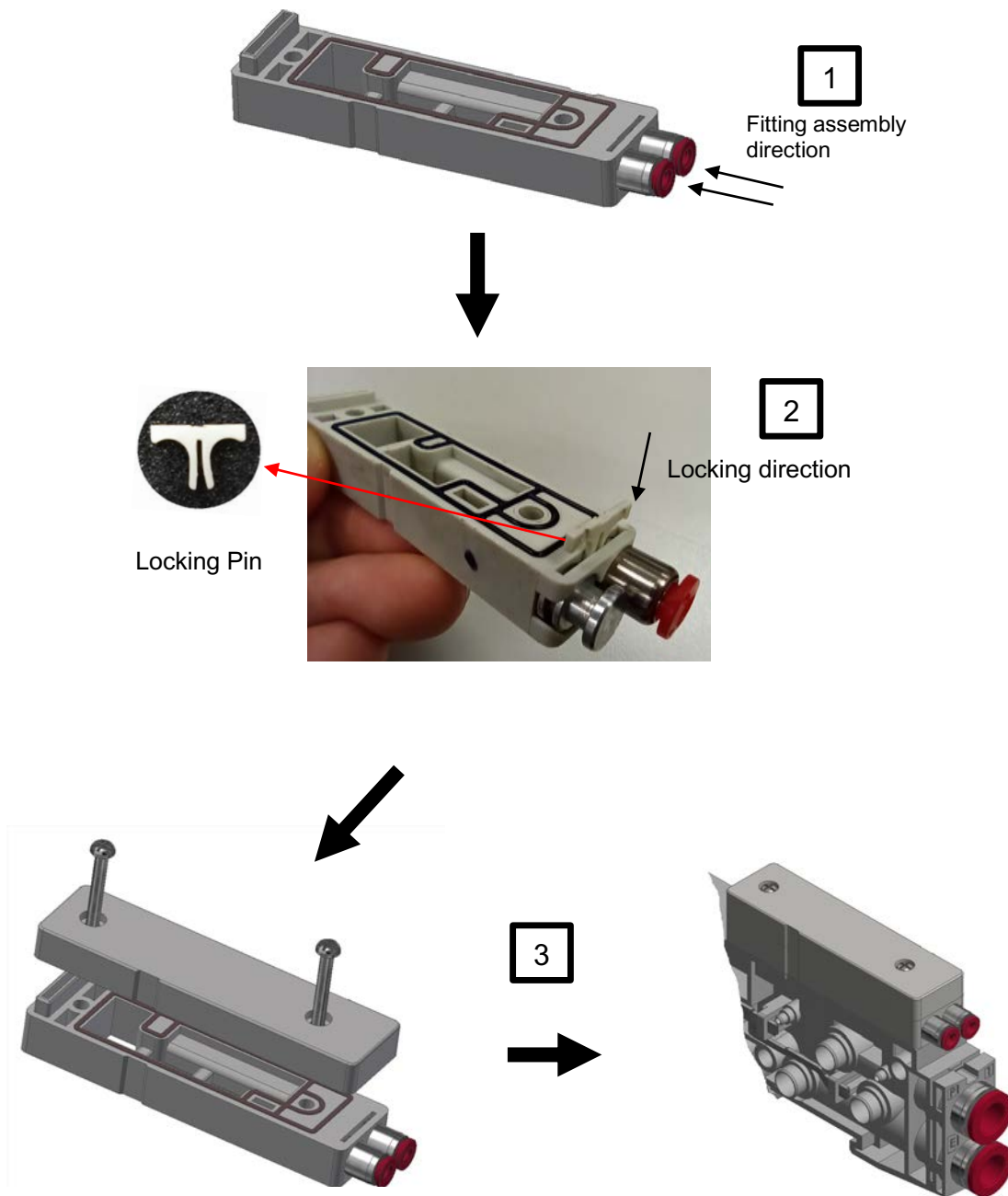

Construction & Design is subject to change (A1743-OPM-MX / Rev.004)

▪ VR10/VR15 Fitting Service Kit

Description	Where used	Part number
Locking Pin	VR10 External Pilot Base VR15 External Pilot Base	A1743-870
Locking Pin	VR10 Sub-Base	A1743-871
Locking Pin	VR10 Supply Exhaust Module; VR15 Sub-Base	A1743-872
Locking Pin	VR15 Supply Exhaust Module	A1743-883
PIF OD 4mm	VR10 External Pilot Base VR15 External Pilot Base	A1743-873
PIF OD 4mm	VR10 Sub-Base	A1743-874
PIF OD 4mm	VR15 Sub-Base	A1743-894
PIF OD 6mm	VR10 Sub-Base	A1743-876
PIF OD 6mm	VR15 Sub-Base	A1743-896
PIF OD 8mm	VR10 Supply Exhaust Module VR15 Sub-Base	A1743-878
PIF OD 10mm	VR15 Supply Exhaust Module	A1743-898
PIF OD 5/32"	VR10 Sub-Base	A1743-875
PIF OD 5/32"	VR10 External Pilot Base VR15 External Pilot Base	A1743-884
PIF OD 5/32"	VR15 Sub-Base	A1743-895
PIF OD 1/4"	VR10 Sub-Base	A1743-877
PIF OD 1/4"	VR15 Sub-Base	A1743-897
PIF OD 5/16"	VR10 Supply Exhaust Module VR15 Sub-Base	A1743-879
PIF OD 3/8"	VR15 Supply Exhaust Module	A1743-899
Blank Plug	VR10 External Pilot Base VR15 External Pilot Base	A1743-880
Blank Plug	VR10 Supply Exhaust Module	A1743-881
Blank Plug	VR15 Supply Exhaust Module	A1743-882

Construction & Design is subject to change (A1743-OPM-MX / Rev.004)

4.1.6.9 Assembling and Disassembling DIN Rail

- Locking torque and structure for DIN Rail clamp

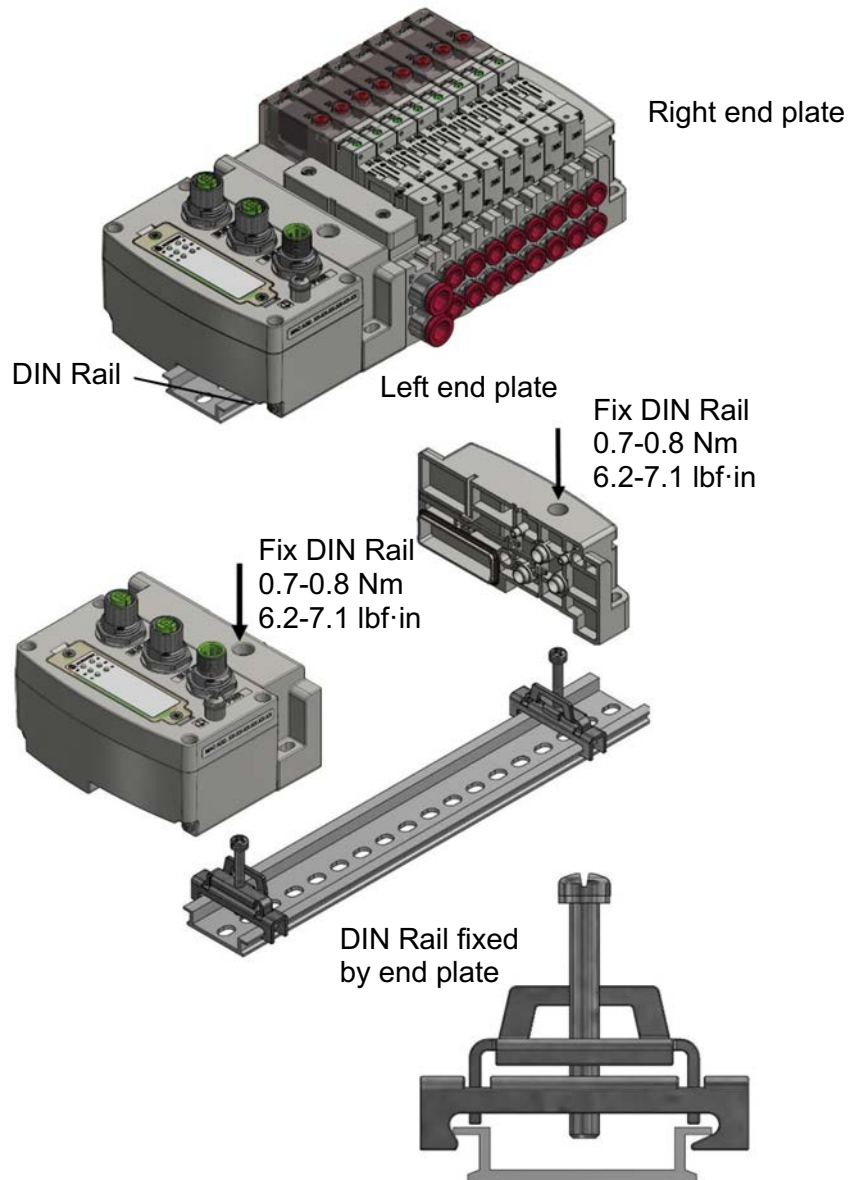

Construction & Design is subject to change (A1743-OPM-MX / Rev.004)

- Assembling valve station onto DIN Rail.
 1. Loose the screws of DIN Rail clamp.
 2. Attach slot at fitting side of the manifold to DIN Rail, then push valve island to lock position as shown.
 3. Tighten the screws of DIN Rail clamp, now the valve island and DIN Rail are fixed together.

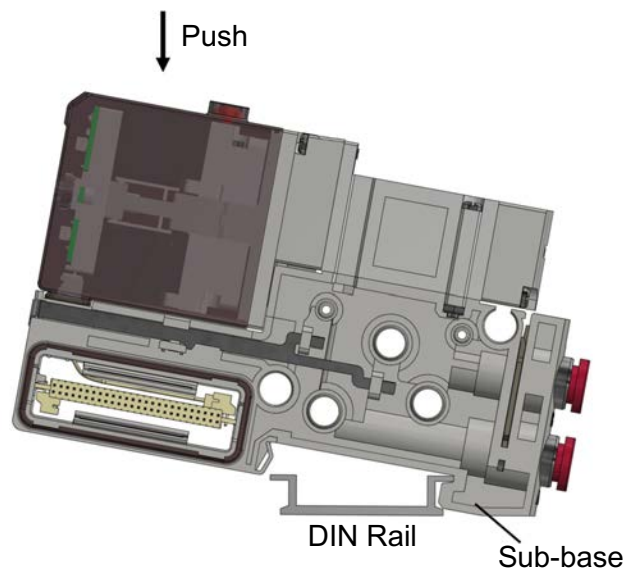

- Dis-engaging valve manifold and DIN Rail
 1. Loose the screws of DIN Rail clamps on both endplates.
 2. Pull side of valve island to dis-engage the DIN Rail as shown.

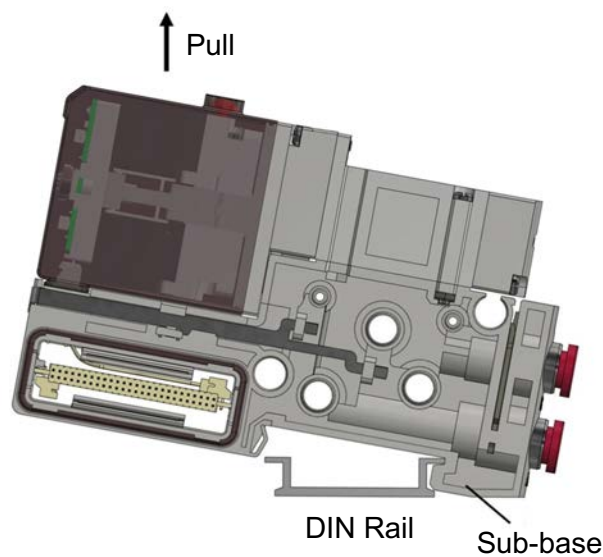

Construction & Design is subject to change (A1743-OPM-MX / Rev.004)

4.1.7 Piping

- Tube Insertion
 1. Cut tubes as per best practice and avoid torn or irregular cut.
 2. Insert tube into fittings until it reaches its end position.
 3. Slowly and softly pull the tube to check if tube is hooked firmly.
- In case of multiple Sup/Exh Modules, it is recommended to use separated air supply line instead of common air supply line.

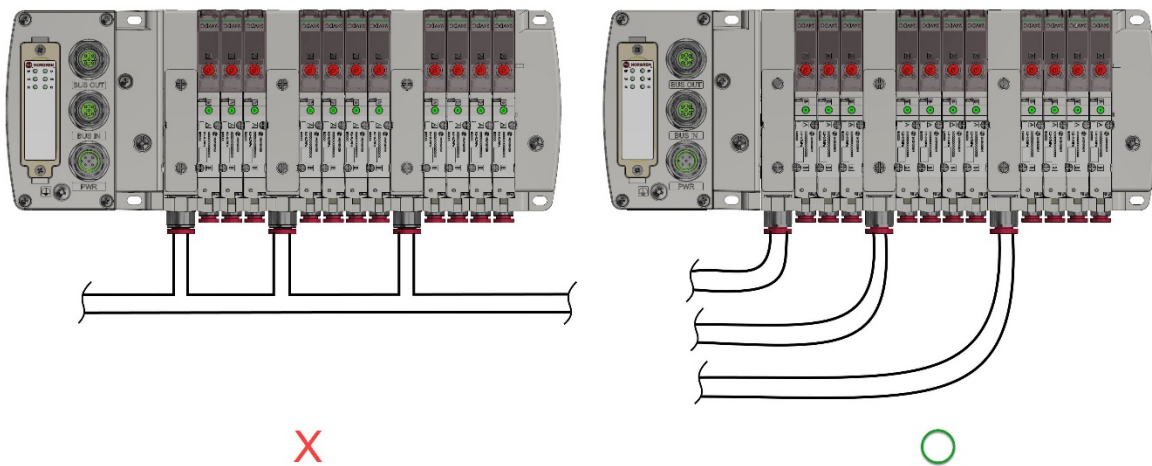

4.1.8 Multi-Pressure Zone Option

- Multi pressure zones can be achieved with additional Sup/Exh Modules and blank plugs.
- Insert the blank plugs at left side for every pressure zone as shown below.
- Blank plug part number: VR10: VR107516AM0400
VR15: VR157516AM0400

Note:

All external pilot pressures are connected on one valve island. Both internal and external pilot valve type can be utilized within its pressure zone on one valve island. In this case, the Sup/Exh Module for internal pilot zone shall not have silencer incorporated. Please find ordering information of Sup/Exh Module & blank plug in the VR10 / VR15 data sheet.

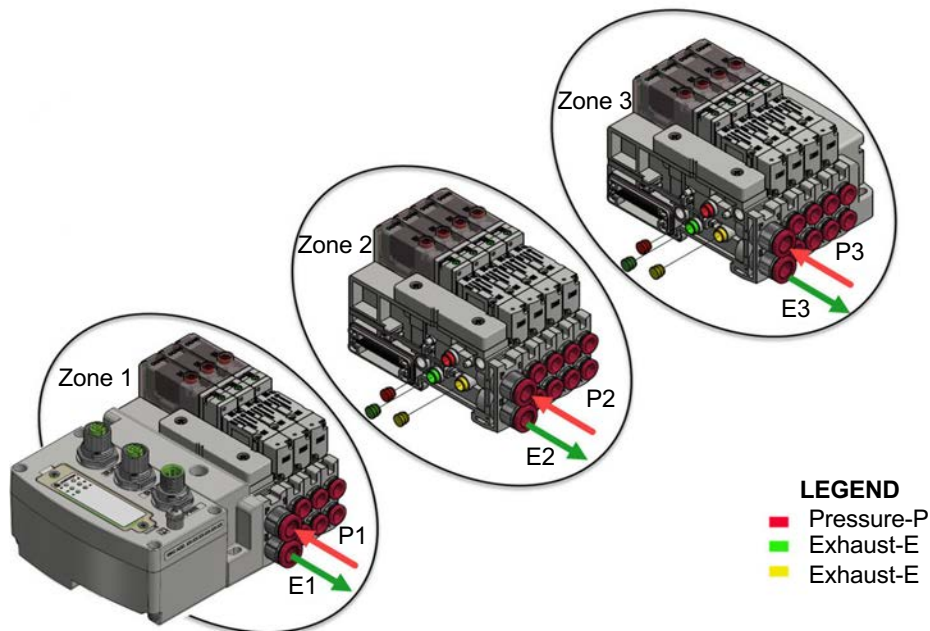

- P1 = Pressure for Zone 1
- P2 = Pressure for Zone 2
- P3 = Pressure for Zone 3
- E1 = Exhaust for Zone 1
- E2 = Exhaust for Zone 2
- E3 = Exhaust for Zone 3

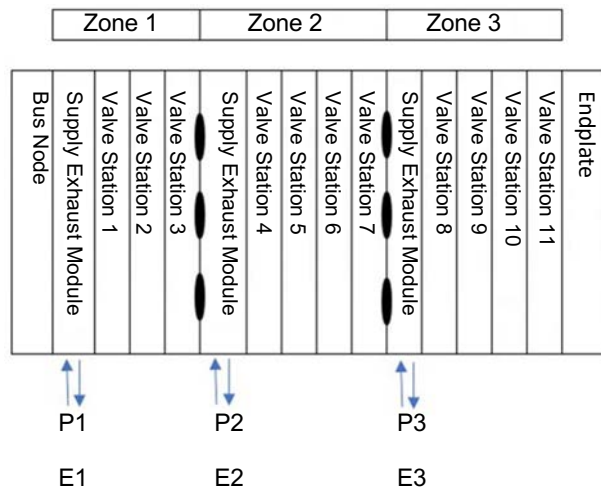

Construction & Design is subject to change (A1743-OPM-MX / Rev.004)

4.2 MAINTENANCE

4.2.1 Lubrication

VR10 / VR15 valves will function reliably when they are supplied with clean dry air. If the air supply is lubricated from the beginning, then lubrication must be supplied for the life of the product.

4.2.2 Valve Identification Information

When purchasing assembled valve islands from NORGREN, valve identification information is included. This information is intended for the top of the valves. You can easily recognize valve type, order spare valves per this valve information, and replace parts yourselves.

When changing parts (such as control modules, valve stations, fittings, Sup/Exh modules etc) of a valve island, the part number on the label will no longer correspond to the configuration.

If you order the valve island based on the NORGREN part number, the original configuration will be delivered.

4.2.3 Spare Parts

Please refer to VR10 / VR15 data sheet or consult NORGREN.

5 TRANSPORT / STORAGE / PACKAGING

- VR10 / VR15 valve islands and components must be protected against impacts. Valve islands and components delivered by NORGREN are protected accordingly.
- VR10 / VR15 valve islands and components must be stored between -5°C and 50°C . If this limit is exceeded, proper function of the components will not be guaranteed.

6 TECHNICAL DATA

6.1 SPECIFICATION

6.1.1 Operation

- Dynamic soft seal spool valve, solenoid pilot operated.

6.1.2 Flow Rate

- **VR10:**
 - 5/2 valve: 220 L/min, Cv 0.22, Kv 0.20
 - 5/3 valve: 270 L/min, Cv 0.27, Kv 0.24
 - 2X3/2 valve: 220 L/min, Cv 0.22, Kv 0.20
- **VR15:**
 - 5/2 valve: 520 L/min, Cv 0.53, Kv 0.47
 - 5/3 valve: 590 L/min, Cv 0.60, Kv 0.54
 - 2X3/2 valve: 460 L/min, Cv 0.47, Kv 0.42

6.1.3 Valve Mounting

- Sub-base, plug in type

6.1.4 Ambient Temperature

- -5°C ... +50°C (+23°F ... 122°F)
(Consult our technical service for use below +2°C)

6.1.5 Medium Temperature

- -5°C ... +50°C (+23°F ... 122°F)

6.1.6 Medium

- Compressed air only.
- Operating pressure range:
Piloting pressure: 2 to 7 bar
Internal pilot type operating pressure: 2 to 7 bar
External pilot type operating pressure: -1 to 7 bar

6.1.7 Air Quality

Filtered, lubricated or non-lubricated compressed air as per ISO 8573-1:2010, Class 3.4.2.
If air source is lubricated, then lubrication must be supplied for the life of the product because the lubricant will wash away all the initial lubrication and shorten valve life.

For more information, please refer to VR10 / VR15 data sheet or consult NORGREN.

6.2 MATERIALS

Valve body	Die-cast aluminium / zinc
Spool	Aluminium
Plastic part	PA / PC
Mounting & screws	Stainless steel
Spring	Stainless steel
Sub-base	PA66
Seal	NBR / HNBR
Electrical contact	Brass tin / gold coated
PCB	Glass epoxy

Construction & Design is subject to change (A1743-OPM-MX / Rev.004)

6.3 PNEUMATIC

6.3.1 Response Time

- Response time measurements are taken according to ISO 12238.
- The typical response time of valve switching is 15ms on / 25ms off (when downstream pressure is at 90% upstream pressure).
- Please contact NORGREN for more information.

6.3.2 Push in Fitting

	Ports 1 (P), 3 (E) & 5 (E)	Ports 2 (B) & 4 (A)
Tube OD - VR10	8 mm, 5/16"	4 mm, 6 mm, 5/32", 1/4"
Tube OD - VR15	10 mm, 3/8"	4 mm, 6 mm, 8 mm, 5/32", 1/4", 5/16"

6.3.3 Valve Function

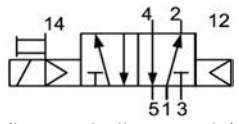
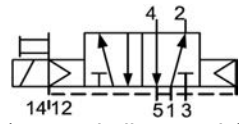
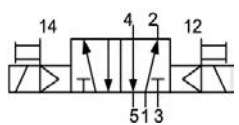
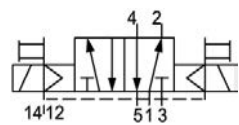
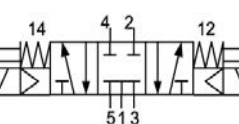
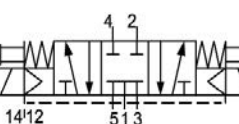
5/2 Sol/Spr	 <p>(internal pilot supply)</p>	 <p>(external pilot supply)</p>
5/2 Sol/Sol	 <p>(internal pilot supply)</p>	 <p>(external pilot supply)</p>
5/3 APB (APB: All ports blocked)	 <p>(internal pilot supply)</p>	 <p>(external pilot supply)</p>

Construction & Design is subject to change (A1743-OPM-MX / Rev.004)

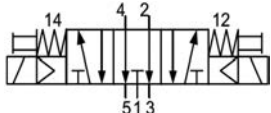
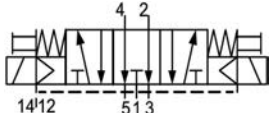
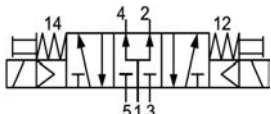
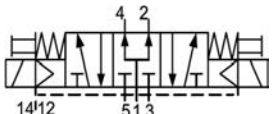
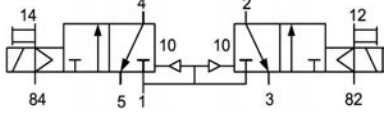
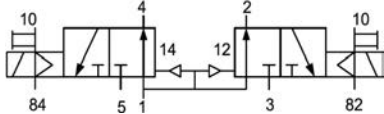
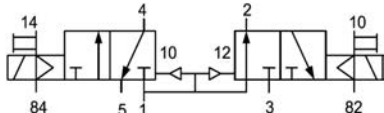
<p>5/3 COE (COE: Centre open exhaust)</p>	 <p>(internal pilot supply)</p>	 <p>(external pilot supply)</p>
<p>5/3 COP (COP: Centre open pressure)</p>	 <p>(internal pilot supply)</p>	 <p>(external pilot supply)</p>
<p>2 x 3/2 NC/NC</p>	 <p>(internal pilot supply only)</p>	
<p>2 x 3/2 NO/NO</p>	 <p>(internal pilot supply only)</p>	
<p>2 x 3/2 NC/NO</p>	 <p>(internal pilot supply)</p>	

6.3.4 Life Expectation

- All VR10 valve types can achieve 30 million cycles at 5 Hz, measurements are taken according to ISO 19973-1.
- All valve types, except 3/2 NO, of VR15 can achieve 30 million cycles at 5 Hz, measurements are taken according to ISO 19973-1. VR15 3/2 NO valve type can achieve 15 million cycles.
- Life cycle is dependent on working conditions such as air quality, working pressure, frequency, etc.

Construction & Design is subject to change (A1743-OPM-MX / Rev.004)

6.4 ELECTRICAL

6.4.1 General Features for Valve Island with Protocols

Supply Voltage:	24 VDC
Voltage Tolerance:	+/- 10% for control module +10%/-5% for solenoid valve
Power Consumption:	0.45W (Energy saving type)
Electrical Connection:	M12x1-Female, 4-pin, D-coded for industrial ethernet M12x1-Male, 5-pin, A-coded for power of control module M12x1-Male, 5-pin, A-coded for IO-Link
Valve Indication:	LED Red solenoid A (14 Solenoid) Green solenoid B (12 Solenoid)
Valve Surge suppression:	Surge protecting circuit default
Valve Polarity:	PNP(negative common) only
Protection class:	IP65

Construction & Design is subject to change (A1743-OPM-MX / Rev.004)

6.4.2 General Features for Valve Island with Multipole D-Sub Connector

Supply Voltage:	12 VDC & 24 VDC
Voltage Tolerance:	+/- 10%
Power Consumption:	0.45W (Energy saving type)
Electrical Connection:	D-Sub Connector 25-Pin
Manual Override:	Push only
Rating:	100% ED
	LED
Indication:	Red solenoid A (14 Solenoid) Green solenoid B (12 Solenoid)
Surge Suppression:	Surge protecting circuit default
Polarity Type:	Both PNP(-common) & NPN(+common) for 24VDC Only PNP(-common) for 12VDC
Protection Class:	IP65 IP40

Construction & Design is subject to change (A1743-OPM-MX / Rev.004)

6.4.3 Wiring Rules for Multipole Series

- The Multipole has 25 pins, and the output follows rules below:
If valve stations ≤ 12 , 2 pins are always reserved for each valve station. *

Detailed pin allocation is shown as below:

Station	#1	#2	#3	#4	#5	#6	#7	#8	#9	#10	#11	#12
Pin No. of Solenoid A (14 Solenoid)	1	2	3	4	5	6	7	8	9	10	11	12
Pin No. of Solenoid B (12 Solenoid)	14	15	16	17	18	19	20	21	22	23	24	25

Notes:

* For valve station with single solenoid, only Pin No. of Solenoid A (14 Solenoid) is connected.

Consider the one which is nearest to D-Sub connector as 1st station (Station #1).

- Mapping relation between station and Pin No. of D-Sub Connector is shown below:

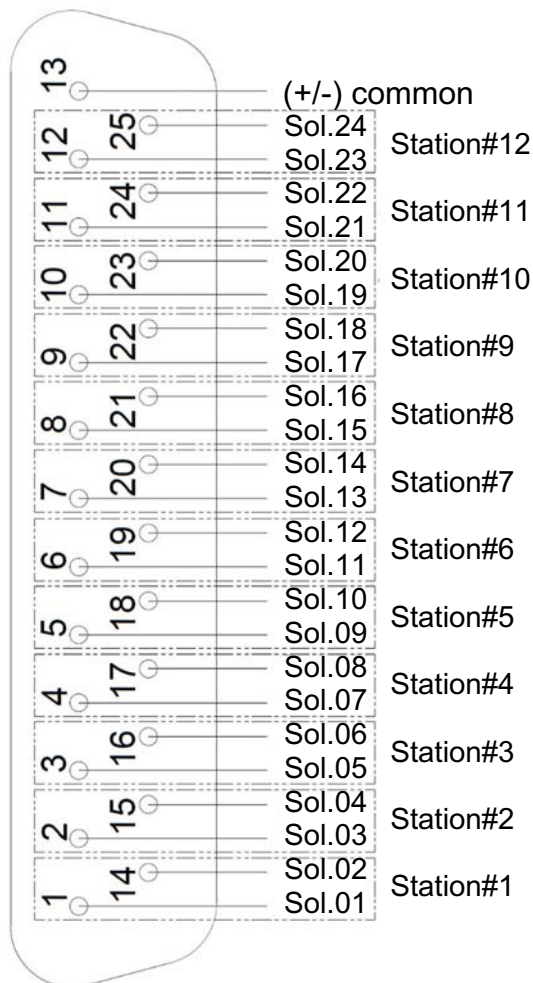

Construction & Design is subject to change (A1743-OPM-MX / Rev.004)

If $12 < \text{valve stations} \leq 24$, special connection is required since only 1 pin is allocated to valve station with single solenoid:

- Step 1: Sequence all solenoids following the rules below by starting from 1st station which is the station closest to control module:
 1. If 1st station is with double solenoids, sequence solenoid A as Sol.01, solenoid B as Sol.02, following 2nd station solenoid A as Sol.03, solenoid B as Sol.04.....
 2. If 1st station is with single solenoid, sequence solenoid A as Sol.01, following 2nd station solenoid A as Sol.02, solenoid B as Sol.03.....
 3. If a station is originally configured as blank, always 2 solenoid numbers are allocated.
 4. The rest of stations should also adhere to the sequence rules above.
- Step 2: Map each Sol. sequence to Pin No. of D-Sub Connector by following the illustration below:

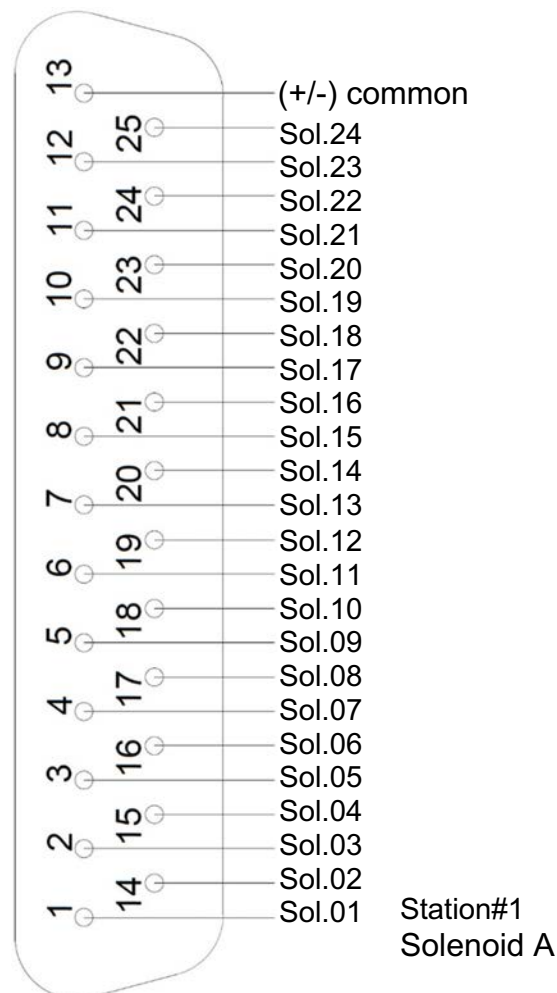

Construction & Design is subject to change (A1743-OPM-MX / Rev.004)

16-station valve island example is shown as below:

	Double Solenoids	Double Solenoids	Single Solenoid	Single Solenoid	Double Solenoids	Double Solenoids	Single Solenoid	Double Solenoids	Single Solenoid	Double Solenoids	Single Solenoid	Double Solenoids	Single Solenoid	Single Solenoid	Double Solenoids	Single Solenoid
Station	#1	#2	#3	#4	#5	#6	#7	#8	#9	#10	#11	#12	#13	#14	#15	#16
Pin No. of Solenoid A (14 Solenoid)	1	2	3	16	4	5	6	19	20	8	9	22	23	11	24	25
Pin No. of Solenoid B (12 Solenoid)	14	15	--*	--*	17	18	--*	7	--*	21	--*	10	--*	--*	12	--*

Note:

*For valve station with single solenoid, only Pin No. of Solenoid A (14 Solenoid) is allocated & connected.

6.4.4 Pin Allocation & Wire Colours for Multipole Series



- IP65 Cable

The allocations of pins and the identification of wire colours are clarified in the following table.

Pin no.	Wire colour	Solenoid	Pilot	Station	Pin no.	Wire colour	Solenoid	Pilot	Station
1	White	Solenoid 1-a	14	1	14	Brown/Green	Solenoid 1-b	12	1
2	Brown	Solenoid 2-a	14	2	15	White/Yellow	Solenoid 2-b	12	2
3	Green	Solenoid 3-a	14	3	16	Yellow/Brown	Solenoid 3-b	12	3
4	Yellow	Solenoid 4-a	14	4	17	White/Grey	Solenoid 4-b	12	4
5	Grey	Solenoid 5-a	14	5	18	Grey/Brown	Solenoid 5-b	12	5
6	Pink	Solenoid 6-a	14	6	19	White/Pink	Solenoid 6-b	12	6
7	Blue	Solenoid 7-a	14	7	20	Pink/Brown	Solenoid 7-b	12	7
8	Red	Solenoid 8-a	14	8	21	White/Blue	Solenoid 8-b	12	8
9	Black	Solenoid 9-a	14	9	22	Brown/Blue	Solenoid 9-b	12	9
10	Violet	Solenoid 10-a	14	10	23	White/Red	Solenoid 10-b	12	10
11	Grey/Pink	Solenoid 11-a	14	11	24	Brown/Red	Solenoid 11-b	12	11
12	Red/Blue	Solenoid 12-a	14	12	25	White/Black	Solenoid 12-b	12	12
13	White/Green	Common	--	--					

* This table is applicable to the D-Sub cables that NORGRN supplies, IP65 cable.

Part numbers V11569-E01, V11569-E03 and V11569-E05.

* The red border example indicates corresponding relation among pins, solenoids, pilot coil and stations based on configuration (12 stations, double solenoids) shown in table in section [6.4.3](#).

▪ IP40 Cable

The allocations of pins and the identification of wire colours are clarified in the following table.

Pin no.	Wire colour	Solenoid	Pilot	Station
1	Black	Solenoid 1-a	14	1
2	Black, White	Solenoid 2-a	14	2
3	Brown	Solenoid 3-a	14	3
4	Brown, White	Solenoid 4-a	14	4
5	Red	Solenoid 5-a	14	5
6	Red, Yellow	Solenoid 6-a	14	6
7	Red, White	Solenoid 7-a	14	7
8	Pink	Solenoid 8-a	14	8
9	Pink, White	Solenoid 9-a	14	9
10	Yellow	Solenoid 10-a	14	10
11	Yellow, Red	Solenoid 11-a	14	11
12	Yellow, Blue	Solenoid 12-a	14	12
13	Green	Common	--	--

Pin no.	Wire colour	Solenoid	Pilot	Station
14	Green, Yellow	Solenoid 1-b	12	1
15	Green, White	Solenoid 2-b	12	2
16	Blue	Solenoid 3-b	12	3
17	Blue, Yellow	Solenoid 4-b	12	4
18	Blue, White	Solenoid 5-b	12	5
19	Violet	Solenoid 6-b	12	6
20	Violet, White	Solenoid 7-b	12	7
21	Grey	Solenoid 8-b	12	8
22	Grey, Red	Solenoid 9-b	12	9
23	White	Solenoid 10-b	12	10
24	White, Red	Solenoid 11-b	12	11
25	White, Blue	Solenoid 12-b	12	12

* This table is applicable to the D-Sub cables that NORGRN supplies, IP40 cable.

Part numbers VR10569-E15, VR10569-E03 and VR10569-E05.

* The red border example indicates corresponding relation among pins, solenoids, pilot coil and stations based on configuration (12 stations, double solenoids) shown in table.

6.4.5 Wire Connection for Valve Island with Protocols

- Connector identification for PROFINET / EtherNet/IP / EtherCAT protocol
- Proper grounding will assure the safety and noise resistance for the valve island. Grounding should be close to the product.

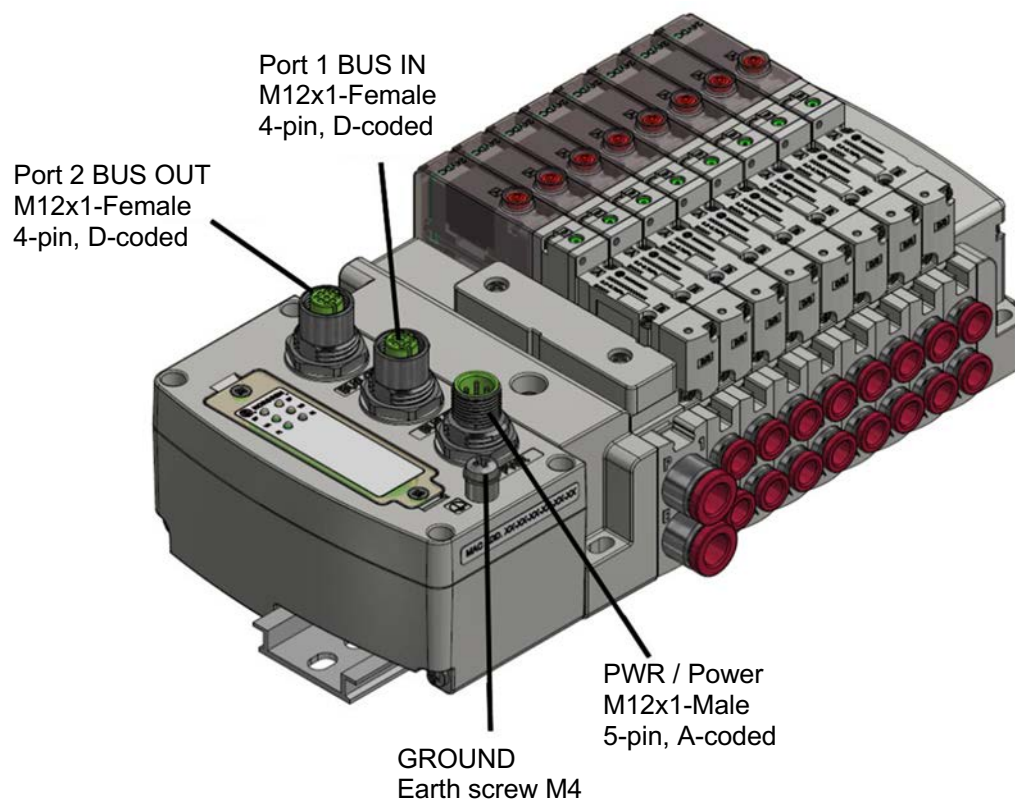

Construction & Design is subject to change (A1743-OPM-MX / Rev.004)

- Pin Allocation of Port 1 / Port 2



M12 / 4 pins / Female Connector / D-coded	
Pin No.	Function
1	Transmission Data + (TD +)
2	Receive Data + (RD +)
3	Transmission Data - (TD -)
4	Receive Data - (RD -)

- Pin Allocation of PWR / Power



M12 / 5 pins / Male Connector / A-coded	
Pin No.	Function
1	L1 (VB +) 24V electronics power supply
2	N2 (VA -) 0V valves power supply
3	N1 (VB -) 0V electronics power supply
4	L2 (VA +) 24V valves power supply
5	FE (functional earth)

- Power connector wiring diagram

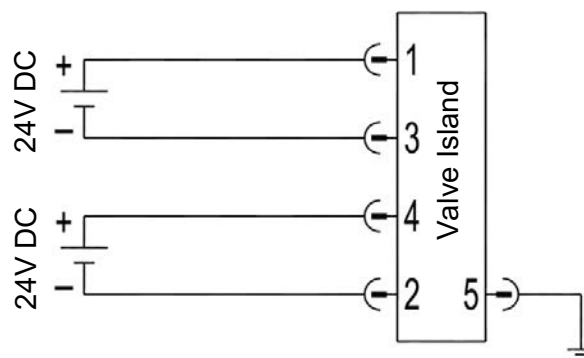

Notes:

Make sure electronics power, valves power and their polarities are connected to correct pins respectively before switching on.
Select the appropriate cables to mate with the connectors mounted on the control module.
Connect the earth screw to ground.

- Control Module Connection for IO-Link Device

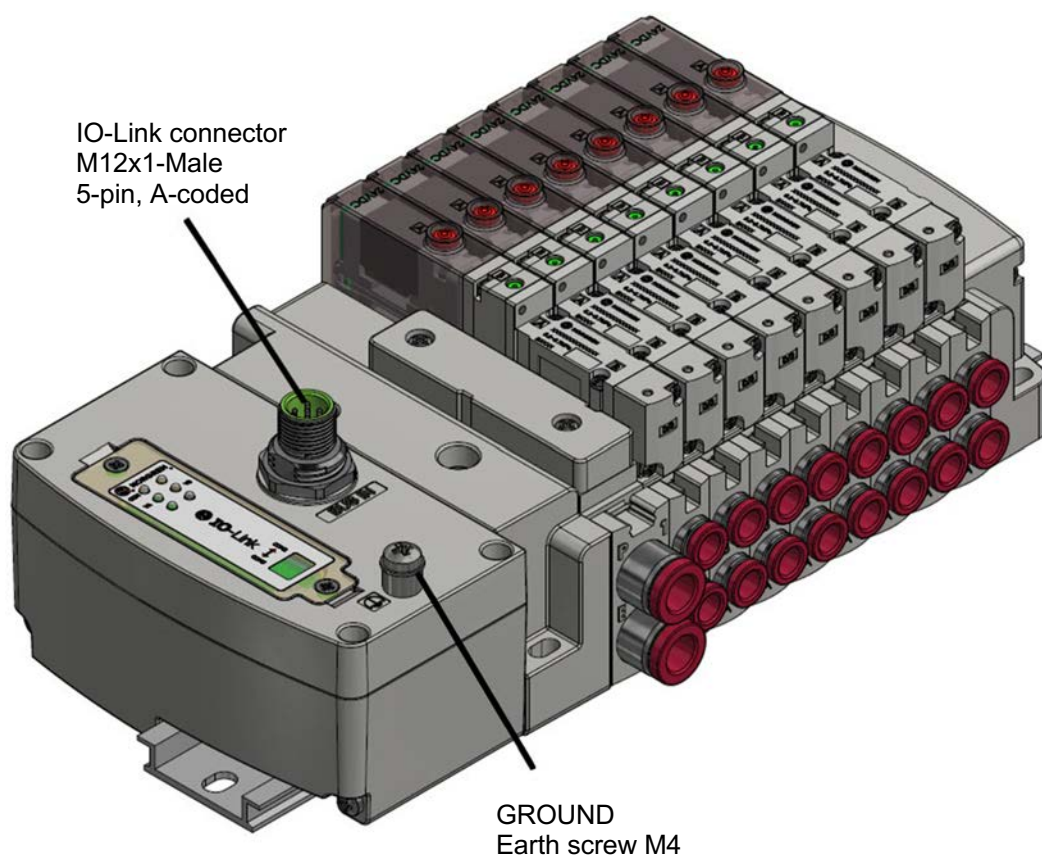

Construction & Design is subject to change (A1743-OPM-MX / Rev.004)

- Pin Allocation Of IO-Link Connector

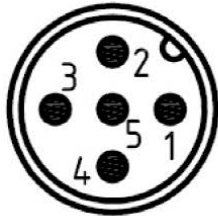

M12 / 5 pins / male connector / A-coded / Class B	
Pin No.	Function
1	L+ (VB+) 24V electronics power supply
2	2L+ (VA+) 24V valves power supply
3	L- (VB-) 0V electronics power supply
4	C/Q (COM) IO-Link communication
5	2M (VA-) 0V valves power supply

- IO-Link Connector Wiring Diagram

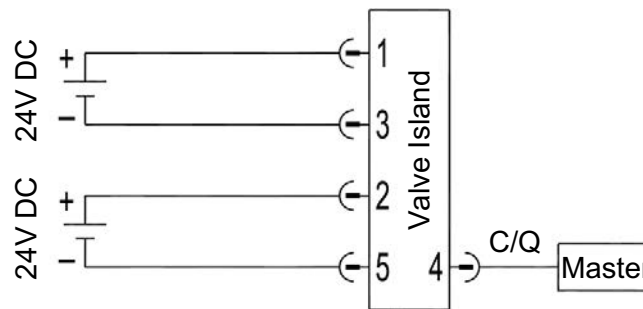

Notes:

- Make sure electronics power, valves power and their polarities are connected to correct pins respectively before switching on.
- Select the appropriate cables to mate with the connectors mounted on the control module.
- Connect the earth screw to ground

6.5 COMPLIANCE AND APPROVALS

The VR10 / VR15 Protocol / Multipole series products are tested and compliant to:

6.5.1 CE marking



Electromagnetic compatibility:

EN 61000-6-4:2007 + A1:2011 Generic standards – Emission standard for industrial environments

EN IEC 61000-6-2:2019 Generic standards – Immunity for industrial environments

EN 61000-4-2:2009 Electrostatic discharge immunity test

EN 61000-4-3:2006 + A1:2008 + A2:2010

Radiated, radio-frequency, electromagnetic field immunity test

EN 61000-4-4:2012 Electrical fast transient/burst immunity test

EN 61000-4-6:2014 Immunity to conducted disturbances, induced by radio-frequency fields

EN 61000-4-8:2010 Power frequency magnetic field immunity test

EN 61000-4-5:2014 + A1:2017 Testing and measurement techniques – Surge immunity test

6.5.2 REACH

EC NO. 1907/2006

6.5.3 RoHS

IEC 62321:2008 Electrotechnical products-Determination of levels of six regulated substances

EN 50581:2012 Technical documentation for the assessment of electrical and electronic products with respect to the restriction of hazardous substances

DIRECTIVE 2011/65/EU

Construction & Design is subject to change (A1743-OPM-MX / Rev.004)

7 CUSTOMER SUPPORT

Norgren operates four global centres of technical excellence and a sales and service network in 50 countries, as well as manufacturing capability in the USA, Germany, China, UK, Switzerland, Czech Republic, Mexico and Brazil.

For information on all Norgren companies visit www.norgren.com
Supported by distributors worldwide.

The data specified above only serve to describe the product.

No statements concerning a certain condition or suitability for a certain application can be derived from our information. The information given does not release the user from the obligation of exercising judgment and verification. It must be remembered that our products are subject to a natural process of wear and ageing.

© This document, as well as the data, specifications and other information presented in it are the sole property of Norgren. It may not be reproduced or given to third parties without their consent.

Subject to change without notice.

EN

Norgren operates four global centres of technical excellence and a sales and service network in 50 countries, as well as manufacturing capability in Brazil, China, Czech Republic, Germany, India, Mexico UK and the USA.

For information on all Norgren companies visit

www.norgren.com

Supported by distributors worldwide.

For further information, scan this QR code or visit www.norgren.com



Norgren, Buschjost, FAS, Herion, Kloehn, Maxseal and Thompson Valves are registered trademarks of Norgren companies.

Due to our policy of continuous development, Norgren reserve the right to change specifications without prior notice.

OM_VR_A1743-OPM-MX en/03/21

Incorporating

