

Pilot regulators are used to control the outlet pressure of a pilot operated regulator (ordered separately)

R41 can be close coupled to a 2" R18 pilot regulator

Conventional pilot regulator provides good pressure regulation, rapid response to changing flow demands, and excellent stability.

Feedback pilot regulator provides superior pressure regulation under changing flow demands where changes in flow demand are not sudden or cyclic.

Constant bleed feature provides maximum sensitivity to system changes



Technical data

Fluid:

Compressed air, neutral gases
 NOTE: Contact technical support for use with other media.

Inlet pressure range:

10 psig (0.7 bar) to 450 psig (31 bar) maximum

Operating temperature:

0° to 175°F (-20° to 80°C) **
 ** Air supply must be dry enough to avoid ice formation at temperatures below 35°F (2°C).

Maximum bleed rate at 50 psig (3.5 bar) outlet pressure:

0.25 scfm (0.12 dm³/s) †
 †Maximum bleed rate occurs under dead-end (no flow) conditions.

Pilot ports:

1/4" PTF, ISO G
 R41 feedback port: 1/8" PTF, ISO G

Materials

Body, bonnet: aluminum
 Valve: PTFE
 Elastomers: nitrile

Ordering information

Models listed are relieving with constant bleed, 10 to 250 psig (0.7 to 17 bar) outlet pressure adjustment range*, PTF ports.

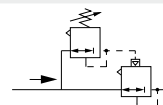
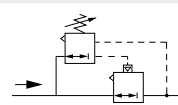
ISO Symbols	Port Size	Type	Model	Flow† scfm (dm ³ /s)	Weight lb (kg)
	1/4"	Conventional Pilot	R40-200-BNSA	6.4 (3)	1.66 (0.75)
					
R40 Conventional Pilot Regulator with Pilot Operated Regulator	1/4"	Feedback Pilot	R41-204-BNSA††	6.4 (3)	1.66 (0.75)

† Typical flow with 100 psig (7 bar) inlet pressure, 90 psig (6.3 bar) set pressure and 15 psig (1 bar) droop from set.

†† Do not use the R41 feedback pilot regulator to control outlet pressures at or less than 100 psig (7 bar). Use the 11-104 feedback pilot regulator at those pressures.

Alternative Models

Type	Substitute	R★★-2★★-BN★★		Threads	Substitute
R40 Conventional	40	←	→	PTF	A
R41 Feedback	41			ISO G parallel	G
Mounting/Type	Substitute	←	→	Outlet Pressure Adjustment Ranges*	Substitute
Remote/R40 Conventional	00			5 to 125 psig (0.3 to 8.5 bar) R40 only	L
Remote/R41 Feedback	04	10 to 250 psig (0.7 to 17 bar)	S		

* Outlet pressure can be adjusted to pressures in excess of, and less than, those specified. Do not use these units to control pressures outside of the specified ranges.

Feedback Pilot Regulator Warning

The feedback line must sense the pilot operated regulator outlet pressure and must be connected before turning on the air supply. If the feedback line is not connected, the pilot operated regulator outlet pressure will rapidly increase to the inlet pressure when the adjusting knob on the pilot regulator is turned clockwise.

Panel mounting hole diameter: 1.89" (48 mm)
Maximum panel thickness: 0.13" (3 mm)

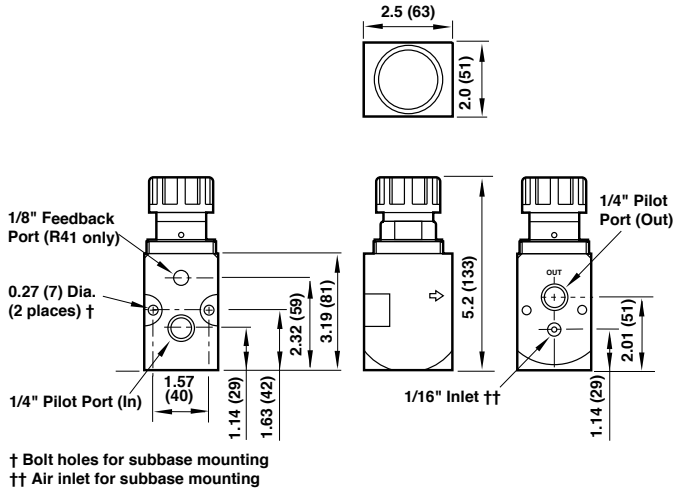

Typical Performance Characteristics

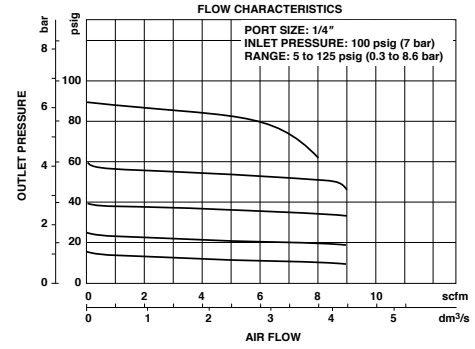

Service Kits

Type	Part number
R40, R41	5945-41

Service kit contains diaphragm, valve spring, guide bushing, valve, valve spring, filter screen, and all o-rings.

Dimensions in inches (mm)