

- > **Port size: G1/8 ... G1**
- > **Prevent the ingress of dirt with minimal flow restriction**
- > **Robust and compact**
- > **Screw directly into the exhaust port**
- > **Wide temperature range**
- > **Shock and vibration resistant to EN 61373, Category 1, class A and B**

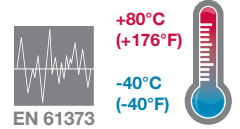

### Technical features

**Medium:**

Compressed air, filtered, lubricated or non-lubricated, inert gases

**Operation:**

Exhaust filter

**Operating pressure:**

10 bar ( 145 psi) max.

**Port size:**

G1/8, G1/4, G1/2, G3/4, G1

**Mounting:**

Directly in the exhaust port

**Ambient/Media temperature:**

-40°C ... +80°C (-40 ... +176°F)

Air supply must be dry enough to avoid ice formation at temperatures below +2°C (+35°F).

**Materials:**

Body: aluminium alloy  
 Element: sintered bronze

### Technical data

Symbol	Port size	Flow factor C *1)	Cv	Kv *2)	Weight (kg)	Model
	G 1/8	2	0,49	0,426	0,006	M/1511
	G 1/4	5,6	1,37	1,19	0,018	M/1512
	G 1/2	11,2	2,75	2,39	0,030	M/1514
	G 3/4	20,6	5,05	4,39	0,050	M/1516
	G 1	26,4	6,47	5,62	0,091	M/1518

\*1) Measured in m<sup>3</sup>/(s. bar)

\*2) Measured in m<sup>3</sup>/h

### Dimensions

Dimensions in mm  
 Projection/First angle

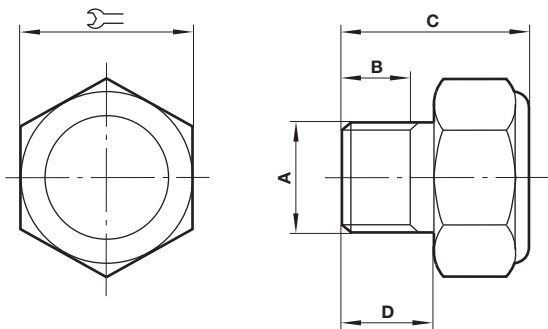

A	B	C	D		Model
G 1/8	6	16	8	15	M/1511
G 1/4	8	22	10	23,5	M/1512
G 1/2	10,5	25	13	30,5	M/1514
G 3/4	14	31	16	42,5	M/1516
G 1	15	35	19	47	M/1518

### Warning

These products are intended for use in industrial compressed air and rail transport systems only. Do not use these products where pressures and temperatures can exceed those listed under »**Technical features/data**«.

Before using these products with fluids other than those specified, for non-industrial applications, life-support systems or other applications not within published specifications, consult IMI Precision Engineering, Norgren Ltd.

Through misuse, age, or malfunction, components used in fluid power systems can fail in various modes.

The system designer is warned to consider the failure modes of all component parts used in fluid power systems and to provide adequate safeguards to prevent personal injury or damage to equipment in the event of such failure.

System designers must provide a warning to end users in the system instructional manual if protection against a failure mode cannot be adequately provided.

System designers and end users are cautioned to review specific warnings found in instruction sheets packed and shipped with these products.