

- > Flange interface
- > High flow performance
- > Adjustment can be locked
- > Captive regulator needle will not blow out when unscrewed
- > Adjusting knob position line
- > Wide temperature range
- > Easy installation and maintenance
- > Shock and vibration resistant to EN 61373, Category 1, Class A and B

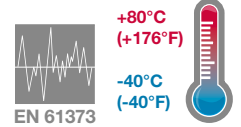

Technical features

Medium:

Compressed air, filtered, lubricated or non-lubricated, inert gas

Operation:

Flow regulators (bi-directional)

Operating pressure:

0 ... 10 bar (0 ... 145 psi)

Mounting:

Flange

Ambient/Media temperature:

-40 ... +80°C max. (-40 ... +176°F)
 Air supply must be dry enough to avoid ice formation at temperatures below +2°C (+35°F)

Materials:

Body: Aluminium alloy
 Seal: Low nitrile
 Needle & internal parts: Brass
 External parts: Aluminium alloy

Technical data

Symbol	Port size	Max. regulated flow factor		Kv *2)	Operating pressure (bar)	Weight (kg)	Model
		C *1)	Cv				
	Flange interface	1,6	0,39	0,34	0 ... 10	0,1	LT1100Z2800

*1) Measured in dm³/(s.bar)

*2) Measured in m³/h

Dimensions

Dimensions in mm
Projection/First angle

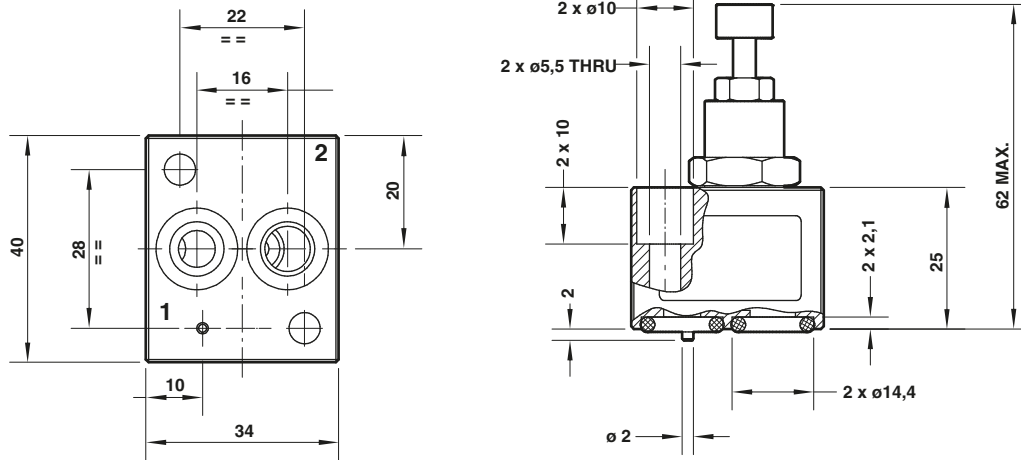

Warning

These products are intended for use in industrial compressed air and rail transport systems only. Do not use these products where pressures and temperatures can exceed those listed under »**Technical features/data**«. Before using these products with fluids other than those specified, for non-industrial applications, life-support systems or other applications not within published specifications, consult IMI Precision Engineering, Norgren Co. Ltd.

Through misuse, age, or malfunction, components used in fluid power systems can fail in various modes. The system designer is warned to consider the failure modes of all component parts used in fluid power systems and to provide adequate safeguards to prevent personal injury or damage to equipment in the event of such failure.

System designers must provide a warning to end users in the system instructional manual if protection against a failure mode cannot be adequately provided.

System designers and end users are cautioned to review specific warnings found in instruction sheets packed and shipped with these products.