

FAS 15 mm MICROSOL MS-E

Media separated solenoid valve

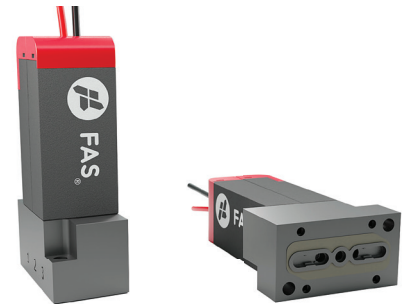

- > 3/2 UNI, media separated
- > For aggressive and sensitive media
- > For medical device, analytical and diagnostic applications
- > For ink jet printing applications
- > Low internal volume
- > Cost effective solution
- > Manifold mounting or barb fittings



Technical features

Medium:

Neutral or aggressive gases and liquids

Operation:

Direct acting 3-way media separated valves

Operating pressure:

-0,95 ... 2,2 bar (-13,8 ... 31,9 psi)

Flow:

kv: 0,5; flow: 33 l/min at $\Delta p = 2$ bar, 20°C (+68°F)

Mounting:

Manifold or barb fittings

Orifice:

1,6 mm

Life expectancy:

≥10 Mio. cycles

Weight:

30 g (1,06 lbs)

Ambient/media temperature:

EPDM: +0 ... +50°C (+32 ... +122°F)

FFPM: +10 ... +50°C (+50 ... +122°F)

Materials:

Body in contact with media: PEEK or PVDF

Seal and diaphragm material in contact with media: FFPM or EPDM

Electrical details

Voltage tolerance:	±5%
Voltage:	24 V.d.c. (>50ms)
Rating:	100% E.D.
Power consumption:	4/0,4W
Pulse width modulation:	Integrated
Revert polarity detection:	Integrated
Electrical connection:	300 mm flying leads AWG24
Electrical insulation:	1500 V.a.c.
Insulation class:	F (155°C)
Protection class:	IP51
Cycle rate:	< 4Hz

Following options on request

Materials
Coil orientation
Voltage
Electrical connection (leads)
Interface design
Pressure
Orifice sizes

Embedded electronics options

Without integrated pulse width modulation

Technical data - standard models

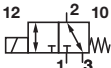
Symbol	Orifice (mm)	Operating pressure (bar)	Operating pressure (psi)	Back pressure max *1) (bar)	Back pressure (psi)	kv *2) (l/)	Voltage [V.d.c.]	Power consumption *3) [W]	Seal / Diaphragm Material	Model	Mounting
	1,6	-0,95 ... 2,2	-13,8 ... 31,9	1,10	15,95	0,5	24	4/0,4	PVDF/EPDM	31-333EB03-55+23A12+AZU	Manifold
	1,6	-0,95 ... 2,2	-13,8 ... 31,9	1,10	15,95	0,5	24	4/0,4	PEEK/EPDM	31-333EB03-B5+23A12+AZU	Manifold
	1,6	-0,95 ... 2,2	-13,8 ... 31,9	1,10	15,95	0,5	24	4/0,4	PEEK/FFPM	31-333EB03-B6+23A12+AZU	Manifold
	1,6	-0,95 ... 2,2	-13,8 ... 31,9	1,10	15,95	0,5	24	4/0,4	PEEK/FFPM	31-333N-03-B6+23A12+AZU	Barb Fittings
	1,6	-0,95 ... 2,2	-13,8 ... 31,9	1,10	15,95	0,5	24	4/0,4	PVDF/EPDM	31-333N-03-55+23A12+AZU	Barb Fittings

*1) Maximum back pressure during commutation: 50% of operating pressure

*2) Cv = 0,07 kv

*3) Power consumption: "boosting power during approx 50 ms" / "holding power"

Dimensions

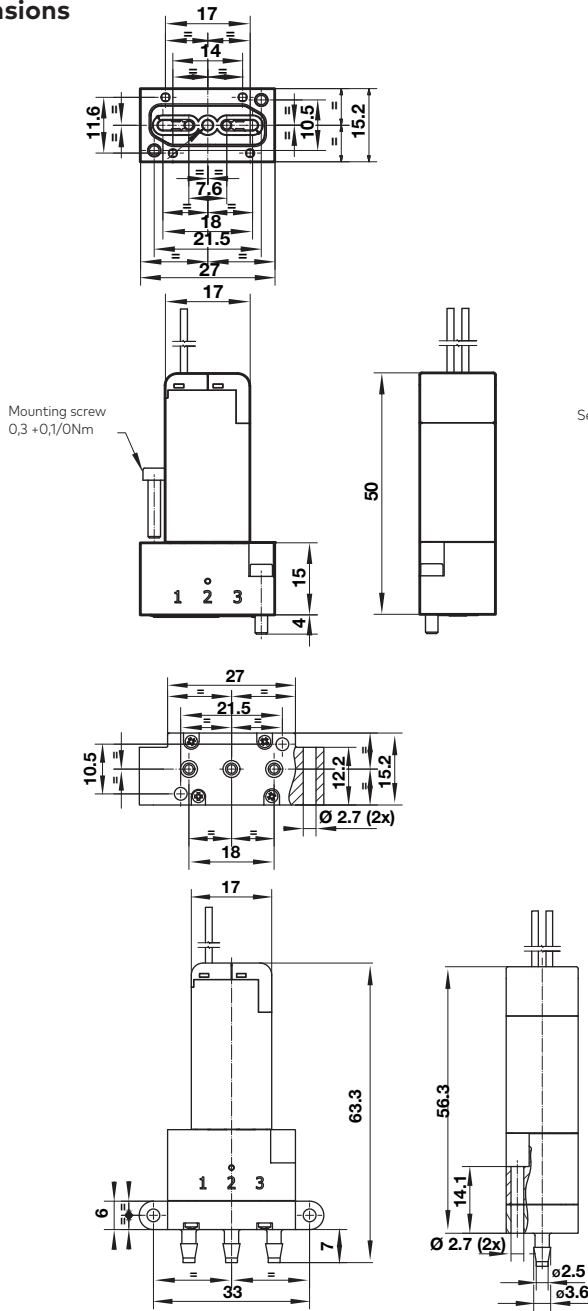

Dimensions shown in mm
Projection/First angle

Connecting area

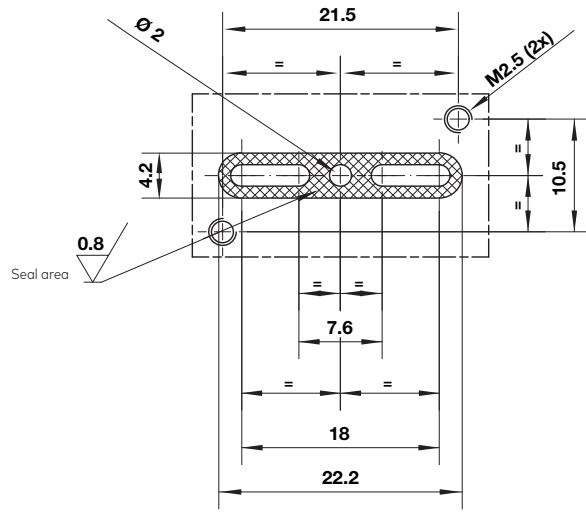

All solenoids are supplied with mounting screws and gasket,

Accessories

**Mounting M5 manifold with M5 threads - 1 position PEEK
Model: S010.2259**

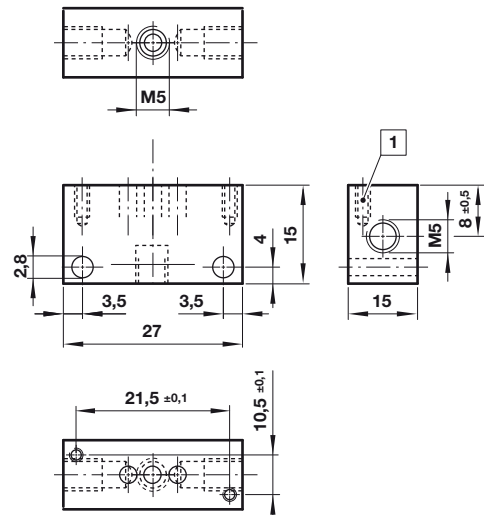

Warning

These products are intended for use with aggressive sensitive media, Please contact FAS Medic SA for more compatibility requests. Do not use these products where pressures and temperatures can exceed those listed under „Technical features/data“. Before using these products with fluids other than those specified, for non-industrial applications, life-support systems or other applications not within published specifications, consult FAS MEDIC SA. Through misuse, age, or malfunction, components used in fluid power systems can fail in various modes.

The system designer is warned to consider the failure modes of all component parts used in fluid power systems and to provide adequate safeguards to prevent personal injury or damage to equipment in the event of such failure. System designers must provide a warning to end users in the system instructional manual if protection against a failure mode cannot be adequately provided. System designers and end users are cautioned to review specific warnings found in instruction sheets packed and shipped with these products.