

- > Port size: DN 15 ... 50
- > High flow rate
- > For robust industry solutions
- > Damped operation
- > Suitable for vacuum
- > Valve operates without differential pressure
- > Solenoid interchangeable without tools (*Click-on*[®])
- > Fluids of Group 2 acc. Pressure Equipment Directive 2014/68/EU
- > International approvals

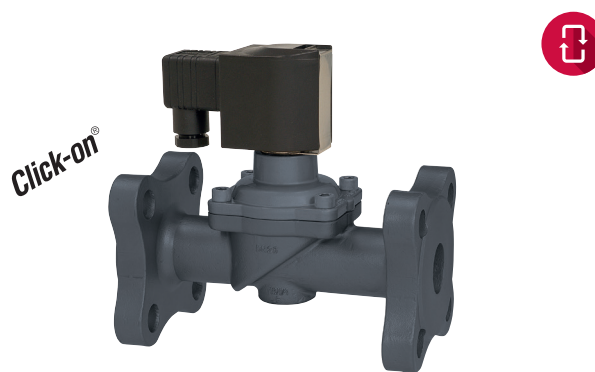

Technical features

Medium:
Neutral gases and liquid fluids

Switching function:
Normally closed

Operation:
Solenoid actuated, with forced lifting

Mounting position:
Optional, preferably solenoid vertical on top

Flow direction:
Determined

Port size:
DN 15, DN 20, DN 25, DN 32, DN 40, DN 50

Operating pressure:
0 ... 10/16 bar (0 ... 145/232 psi)

Fluid temperature:
-10° ... +90°C (+14° ... +194°F)

Ambient temperature:
-10° ... +50°C (+14° ... +122°F)

Material:
Body: Cast steel, Brass
Seat seal: NBR
Internal parts: Stainless steel, PVDF, Brass

For contaminated fluids insertion of a strainer is recommended.

Technical data - standard models

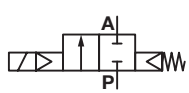
Symbol	Orifice (mm)	Flow kv value *1) (m³/h)	Operating pressure *2) (bar / psi)		Weight (kg)	Model Solenoid in V d.c.	Model Solenoid in V a.c.
	15	3,4	0 ... 10	0 ... 145	1,9	8304200.9151.xxxxx	8304200.9154.xxxxx
	15	3,4	0 ... 16	0 ... 232	2,4	8304200.8301.xxxxx	8304200.8304.xxxxx
	20	5,8	0 ... 10	0 ... 145	2,5	8304300.9151.xxxxx	8304300.9154.xxxxx
	20	5,8	0 ... 16	0 ... 232	3	8304300.8301.xxxxx	8304300.8304.xxxxx
	25	8	0 ... 10	0 ... 145	3	8304400.9151.xxxxx	8304400.9154.xxxxx
	25	8	0 ... 16	0 ... 232	3,5	8304400.8301.xxxxx	8304400.8304.xxxxx
	32	23	0 ... 16	0 ... 232	6,7	8304500.9401.xxxxx	8304500.9404.xxxxx
	40	25	0 ... 16	0 ... 232	7,4	8304600.9401.xxxxx	8304600.9404.xxxxx
	50	41	0 ... 16	0 ... 232	10	8304700.9401.xxxxx	8304700.9404.xxxxx

xxxxx Please insert voltage and frequency codes

*1) Cv-value (US) ≈ kv value x 1,2

*2) For gases and liquid fluids up to 25 mm²/s (cSt)

Option selector

8304★★★★★★.★★★★★★

Port size	Substitute
15	2
20	3
25	4
32	5
40	6
50	7
Valve options	Substitute
Normally open (NO), up to DN 25 with solenoid 9150 max. 10 bar (145 psi), with solenoid 8300 max. 16 bar (232 psi), with solenoid 9300 max. 16 bar (232 psi), from DN 32 only with solenoid 8400 max. 16 bar (232 psi)	01
Manual override	02
Seat seal FPM, Fluid temperature -5 ... +110°C	03
Seat seal EPDM, for hot water, Fluid temperature -10 ... +110°C	14
Normally open (NO), Seat seal FPM, Fluid temperature -5 ... +110°C, from DN 32 only with solenoid 8400	17
Flanges acc.to ASME B 16.5 150 lb/sq.In.	47

Frequency	Substitute
See table frequency codes	xx
Voltage	Substitute
See Voltage codes	xxx
Solenoid options	Substitute
DN 15 ... 25 Operating pressure 0 ... 10 bar Solenoid in V d.c.	9151
DN 15 ... 25 Operating pressure 0 ... 10 bar Solenoid in V a.c.	9154
DN 15 ... 25 Operating pressure 0 ... 16 bar Solenoid in V a.c.	8301
DN 15 ... 25 Operating pressure 0 ... 16 bar Solenoid in V a.c.	8304
DN 32 ... 50 Operating pressure 0 ... 16 bar Solenoid in V d.c.	9401
DN 32 ... 50 Operating pressure 0 ... 16 bar Solenoid in V a.c.	9404

Standard solenoid systems

Voltage and Frequency Solenoid 9151/9154 *3)					
Code Voltage	Code Frequency	Voltage	Frequency	Inrush	Holding
024	00	24 V d.c.	-	18 W	18 W
024	49	24 V a.c. *4)	40 ... 60 Hz	20 VA	20 VA
110	49	110 V a.c.*4)	40 ... 60 Hz	20 VA	20 VA
120	49	120 V a.c.*4)	40 ... 60 Hz	20 VA	20 VA
230	49	230 V a.c. *4)	40 ... 60 Hz	20 VA	20 VA
Voltage and Frequency Solenoid 9401/9404 *3)					
024	00	24 V d.c.	-	38 W	38 W
024	49	24 V a.c. *4)	40 ... 60 Hz	42 VA	42 VA
110	49	110 V a.c. *4)	40 ... 60 Hz	42 VA	42 VA
120	49	120 V a.c. *4)	40 ... 60 Hz	42 VA	42 VA
230	49	230 V a.c. *4)	40 ... 60 Hz	42 VA	42 VA
Voltage and Frequency Solenoid 8301/8304 *3)					
024	00	24 V d.c.	-	22 W	22 W
024	49	24 V a.c. *4)	40 ... 60 Hz	25 VA	25 VA
110	49	110 V a.c. *4)	40 ... 60 Hz	25 VA	25 VA
120	49	120 V a.c. *4)	40 ... 60 Hz	25 VA	25 VA
230	49	230 V a.c. *4)	40 ... 60 Hz	25 VA	25 VA
Voltage and Frequency Solenoid 8401/8404					
024	49	24 V d.c.	-	40 W	40 W
024	49	24 V a.c. *4)	40 ... 60 Hz	45 VA	45 VA
110	49	110 V a.c. *4)	40 ... 60 Hz	45 VA	45 VA
120	49	120 V a.c. *4)	40 ... 60 Hz	45 VA	45 VA
230	49	230 V a.c. *4)	40 ... 60 Hz	45 VA	45 VA

Electrical details for all solenoid systems

Design	DIN VDE 0580
Voltage range	±10%
Duty cycle	100% ED
Protection class	EN 60529 IP65
Socket	Form A acc. to DIN EN 175301-803 (included)

According to DIN VDE 0580 at a solenoid temperature of +20°C. At operating state temperature the input power of a coil decreases by up to ca. 30% due to physical reasons.

Additional solenoid systems for hazardous areas

ATEX category	ATEX protection class	IP protection class	Solenoid	Standard voltages
II 2G II 2D	Ex eb mb IIC T3 Gb Ex mb tb IIIB T140°C Db	IP66	6120	24 V d.c., 110 V a.c., 230 V a.c.
II 2G II 2D	Ex eb mb IIC T3 Gb Ex mb tb IIIB T140°C Db	IP66	6240	24 V d.c., 110 V a.c., 230 V a.c.
II 3G II 3D	Ex ec IIC T4 Gc Ex tc IIIC T130°C DC	IP65	8426 *5)	24 V d.c.
II 3G II 3D	Ex ec IIC T4 Gc Ex tc IIIC T130°C DC c	IP65	9176 *5)	24 V d.c.
II 3G II 3D	Ex ec IIC T4 Gc Ex tc IIIC T130°C DC	IP65	9426 *5)	24 V d.c.

Attention!

The conditions imposed on the Ex approvals lead to reduction of the permissible standard temperature ranges in the cases of explosion protected solenoids.

*5) D.c. only, for a.c. solenoids with design inspection certificate acc. to category 2, e. g. 6120 or 6240

*3)  coil only (with the exception of solenoid 94xx up to 41 V a.c.)
*4) A.c. only with rectifier plug

Further versions on request!

Section View and Dimensions
DN 15 ... 25 with solenoid 915x (10 bar)

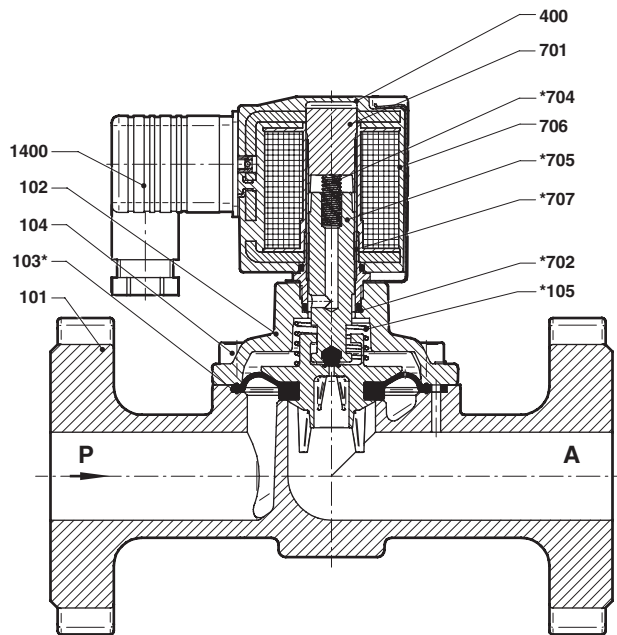

No.	Description
101	Valve body
102	Valve cover
*103	Diaphragm
104	Straight pin
*105	Pressure spring
400	Solenoid
701	Core tube
*702	O-ring
*704	Pressure spring
*705	Core
706	Spring clip
*707	O-ring
1400	Socket (included)

* These individual parts form a complete wearing unit.
 When ordering spare parts please state Cat. No. and Series No.

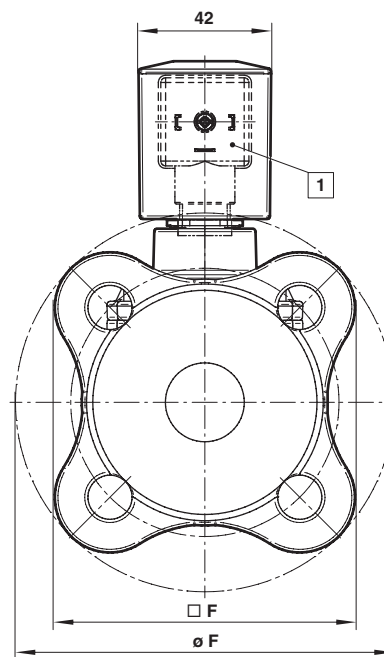
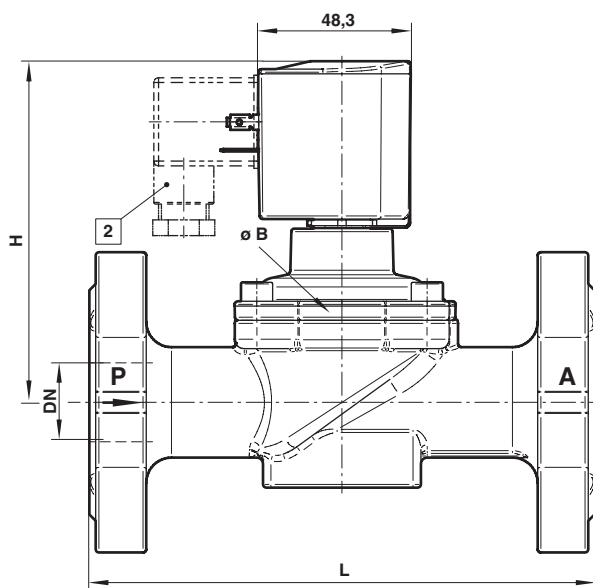

Dimensions in mm
 Projection/First angle



- 1 Solenoid rotatable 360°
- 2 Socket turnable 4 x 90°
 (Socket included)

Orifice (mm)	ø B	ø F	F	H	L	Model
15	44	96	77	97	130	8304200.915x.xxxxx
20	50	110	86,6	105	150	8304300.915x.xxxxx
25	62	120	95,1	108	160	8304400.915x.xxxxx

Contact face acc to. DIN EN 1092-1/B

Section View and Dimensions
DN 15 ... 25 with solenoid 830x (16 bar)

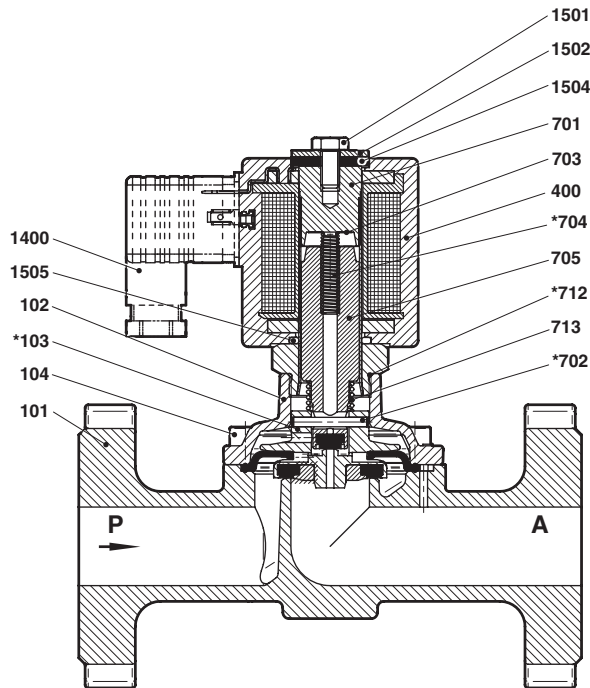

No.	Description
101	Valve body
102	Valve cover
*103	Diaphragm
104	Socket head cap screw
*105	Pressure spring
400	Solenoid
701	Core tube
*702	Straight pin
703	Round plate
*704	Pressure spring
*705	Core
*712	O-ring
*713	Pressure spring
1400	Socket (included)
1501	Hexagon screw
1502	Round plate
1504	Gasket
1505	O-ring

* These individual parts form a complete wearing unit.
When ordering spare parts please state Cat. No. and Series No.

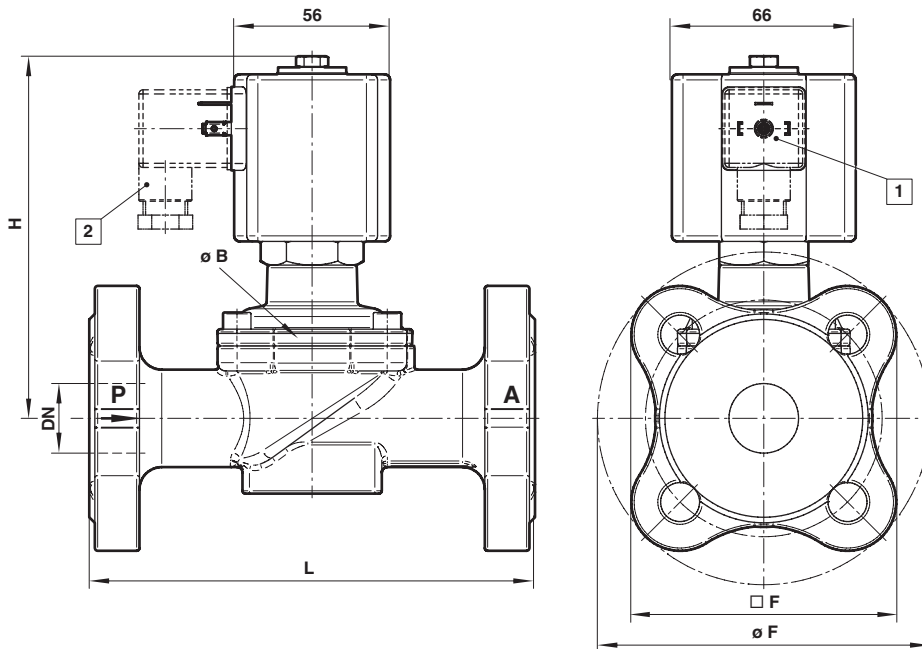

Dimensions in mm
Projection/First angle



- 1 Solenoid rotatable 360°
- 2 Socket turnable 4 x 90°
(Socket included)

Orifice (mm)	ø B	ø F	~ F	H	L	Model
15	44	96	77	157,5	130	8304200.830x.xxxxx
20	50	110	86,6	170	150	8304300.830x.xxxxx
25	62	120	95,1	175	160	8304400.830x.xxxxx

Contact face acc to. DIN EN 1092-1/B

**Section View and Dimensions
DN 32 ... 50 with solenoid 940x (16 bar)**

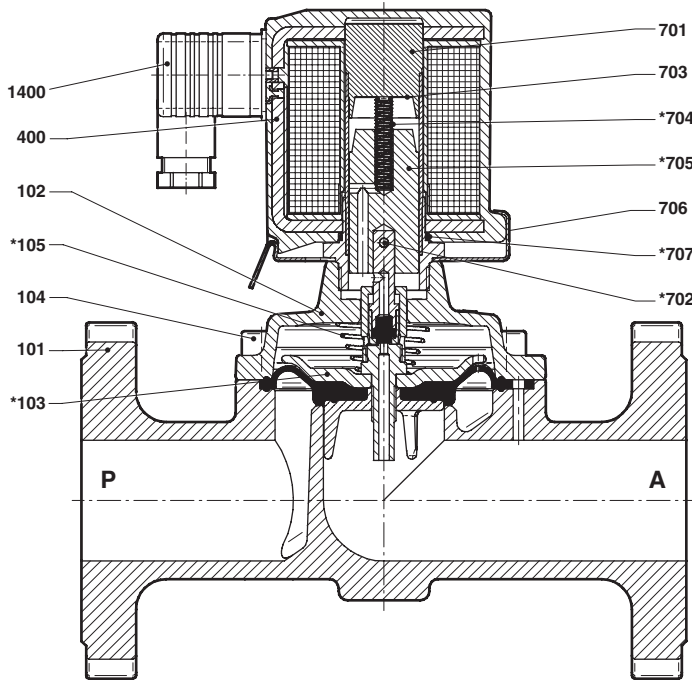

No.	Description
101	Valve body
102	Valve cover
*103	Diaphragm
104	Straight pin
*105	Pressure spring
400	Solenoid
701	Core tube
*702	Straight pin
703	Round plate
*704	Pressure spring
*705	Core
706	Spring clip
*707	O-ring
1400	Socket (included)

* These individual parts form a complete wearing unit.
When ordering spare parts please state Cat. No. and Series No.

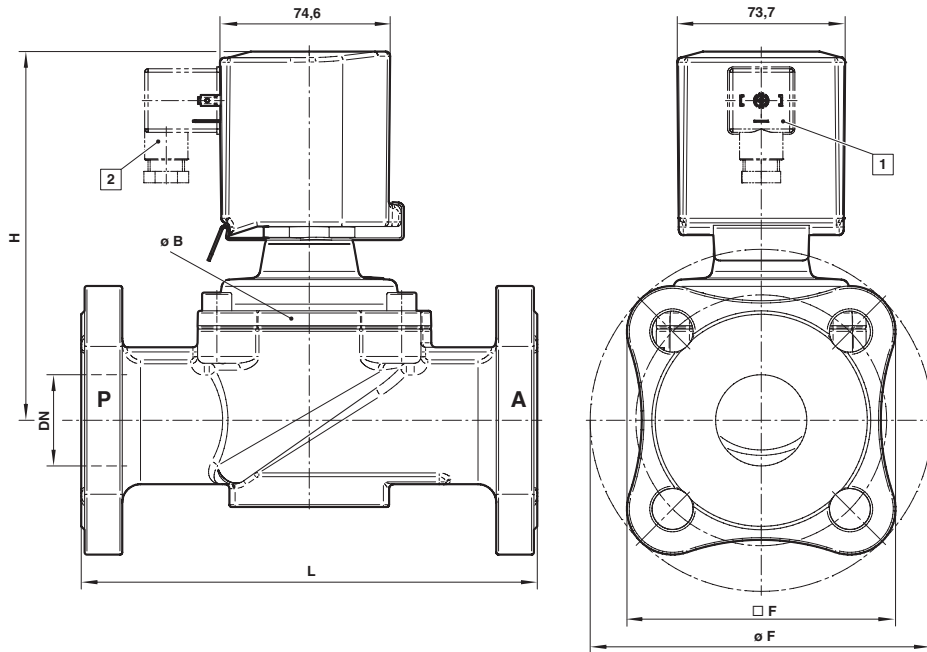

1 Solenoid rotatable 360°
2 Socket turnable 4 x 90°
(Socket included)

Orifice (mm)	ø B	ø F	□ F	H	L	Model
32	92	140	110,7	158	180	8304500.940x.xxxxx
40	92	150	117,8	162	200	8304600.940x.xxxxx
50	109	165	128,4	171	230	8304700.940x.xxxxx

Contact face acc to. DIN EN 1092-1/B

Note to Pressure Equipment Directive (PED):

The valves of this series up to and including DN 25 (G1) are according to Art. 4 § 3 of the Pressure Equipment Directive (PED) 2014/68/EU. This means interpretation and production are in accordance to engineers practice wellknown in the member countries. The CE-sign at the valve does not refer to the PED. Thus the declaration of conformity is not longer applicable for this directive.

For valves > DN 25 (G1) Art. 4 § (1) Letter d) applies:

The basic requirements of the Enclosure I of the PED must be fulfilled. The CE-sign at the valve includes the PED. A certificate of conformity of this directive will be available on request.

Note to Electromagnetic Compatibility Guideline (EEC):

The valves shall be provided with an electrical circuit which ensures the limits of the harmonised standards EN 61000-6-3 and EN 61000-6-1 are observed, and hence the requirements of the Electromagnetic Compatibility Guideline (2014/30/EU) satisfied.

Note to EAC marking:

The EAC-marked products comply with the applicable requirements stated in the technical regulations of the Eurasian Economic Union.