

- > Port size: DN 8 ... 50, G1/4 ... 2, 1/2 ... 2 NPT
- > High flow rate
- > For robust industry applications
- > Damped operation
- > For systems with low or fluctuating pressure
- > Valve operates without differential pressure
- > International approvals

Stainless Steel



Technical features

Medium:
Air, water, gases according to DVGW data sheet G 260 with seat seal FPM, oils and other fluids on request

Switching function:
Normally closed

Operation:
Solenoid operated, with forced lifting

Mounting:
Preferably solenoid vertical on top

Flow direction:
Determined

Port size:
G1/4, G3/8, G1/2, G3/4, G1, G1 1/4, G1 1/2, G2
1/4 NPT, 3/8 NPT, 1/2 NPT, 3/4 NPT, 1 NPT, 1 1/4 NPT, 1 1/2 NPT, 2 NPT

Operating pressure:
0 ... 25 bar (0 ... 362 psi)

Fluid temperature:
-10 ... +60°C (+14 ... +140°F)

Ambient temperature:
-10 ... +50°C (+14 ... +122°F)

Qualification approval:
Single-channel safety-related systems in 85840 accordance with DIN EN 61508 / 61511 up to and including SIL 2 and up to and including SIL 3 in multi-channel systems.

Materials:
Body: Stainless steel (1.4408)
Seat seal: NBR
Internal parts: Stainless steel, PTFE/carbon

Technical data - standard models

Symbol	Port size	Orifice (mm)	Flow kv value *1) (m³/h)	Operating pressure *2) (bar)	(psi)	Weight (kg)	Model Solenoid in V d.c.	Model Solenoid in V a.c.
	G1/4	8	2	0 ... 25	0 ... 362	2,7	8584000.8401.xxxxx	8584000.8404.xxxxx
	1/4 NPT	8	2	0 ... 25	0 ... 362	2,7	8585000.8401.xxxxx	8585000.8404.xxxxx
	G3/8	10	3,2	0 ... 25	0 ... 362	2,7	8584100.8401.xxxxx	8584100.8404.xxxxx
	3/8 NPT	10	3,2	0 ... 25	0 ... 362	2,7	8585100.8401.xxxxx	8585100.8404.xxxxx
	G1/2	12	3,6	0 ... 25	0 ... 362	2,8	8584200.8401.xxxxx	8584200.8404.xxxxx
	1/2 NPT	12	3,6	0 ... 25	0 ... 362	2,8	8585200.8401.xxxxx	8585200.8404.xxxxx
	G3/4	20	6	0 ... 25	0 ... 362	3	8584300.8401.xxxxx	8584300.8404.xxxxx
	3/4 NPT	20	6	0 ... 25	0 ... 362	3	8585300.8401.xxxxx	8585300.8404.xxxxx
	G1	25	8,9	0 ... 25	0 ... 362	3,4	8584400.8401.xxxxx	8584400.8404.xxxxx
	1 NPT	25	8,9	0 ... 25	0 ... 362	3,4	8585400.8401.xxxxx	8585400.8404.xxxxx
	G1 1/4	32	22	0 ... 25	0 ... 362	5,6	8584500.8401.xxxxx	8584500.8404.xxxxx
	1 1/4 NPT	32	22	0 ... 25	0 ... 362	5,6	8585500.8401.xxxxx	8585500.8404.xxxxx
	G1 1/2	40	22,3	0 ... 25	0 ... 362	5,4	8584600.8401.xxxxx	8584600.8404.xxxxx
	1 1/2 NPT	40	22,3	0 ... 25	0 ... 362	5,4	8585600.8401.xxxxx	8585600.8404.xxxxx
	G2	50	35	0 ... 25	0 ... 362	6,8	8584700.8401.xxxxx	8584700.8404.xxxxx
	2 NPT	50	35	0 ... 25	0 ... 362	6,8	8585700.8401.xxxxx	8585700.8404.xxxxx

xxxxx Please insert voltage and frequency codes
 *1) Cv-value (US) ≈ kv value x 1,2
 *2) For gases and liquid fluids up to 25 mm²/s (cSt)

Option selector

858*****.840*.******

Thread form	Substitute
ISO G	4
NPT	5
Port size	Substitute
1/4	0
3/8	1
1/2	2
3/4	3
1	4
1 1/4	5
1 1/2	6
2	7

Frequency	Substitute
See table frequency codes	xx
Voltage	Substitute
See Voltage codes	xxx
Valve options	Substitute
Normally open	01
Seat seal FPM, fluid temperature -10 ... +60°C (+14 ... +140°F)	03
Normally open, Seat seal FPM fluid temperature -10 ... +60°C (+14 ... +140°F)	17
Double position indicator with safety barge and HAN® 7D-connector (metal design)	50

Standard solenoid systems

Voltage and Frequency Solenoid 8401/8404					
Code Voltage	Code Frequency	Voltage	Frequency	Power consumption	
				Inrush	Holding
024	00	24 V d.c.	-	40 W	40 W
024	49	24 V a.c. *3)	40 ... 60 Hz	45 VA	45 VA
110	49	110 V a.c. *3)	40 ... 60 Hz	45 VA	45 VA
120	49	120 V a.c. *3)	40 ... 60 Hz	45 VA	45 VA
230	49	230 V a.c. *3)	40 ... 60 Hz	45 VA	45 VA

*3) a.c. with rectifier plug

Electrical details for all solenoid systems

Design	DIN VDE 0580
Voltage range	±10%
Duty cycle	100% ED
Protection class	EN 60529 IP65
Socket	Form A acc. to DIN EN 175301-803 (included)

According to DIN VDE 0580 at a solenoid temperature of +20°C.

At operating state temperature the input power of a coil decreases by up to ca. 30% due to physical reasons.

Additional solenoid systems for hazardous areas

ATEX category	ATEX protection class	IP protection class	Solenoid	Standard voltages
II 2G II 2D	Ex de IIC T4/T5 Ex tD A21 IP65 T130°C resp. T95°C	IP65	8900	24 V d.c., 110 V a.c., 230 V a.c.
II 2G II 2D	Ex d IIC T4/T5 Ex tD A21 IP65 T130°C resp. T95°C	IP65	8920	24 V d.c., 110 V a.c., 230 V a.c.
II 3G II 3D	Ex ec IIC T4 Gc Ex tc IIIC T130°C DC	IP 65	8426 *4)	24 V d.c.
II 2G II 2D	Ex eb mb IIC T3 Gb Ex mb tb IIIB T140°C Db	IP66	6240	24 V d.c., 110 V a.c., 230 V a.c.

Attention!

The conditions imposed on the Ex approvals lead to reduction of the permissible standard temperature ranges in the cases of explosion protected solenoids.

*4) only DC, for AC solenoids with design inspection certificate acc. to category 2, e.g. 8900/ 8920/ 6240

Inspection certificate DIN EN 10204 - 3.1

1237463.0000

up to G1: material quality proof for:

- Function and seal test (DIN EN 12266)
- Pressure test (DIN EN 12266)
- Voltage test (DIN, VDE 580 § 38)
- Material from parts list with material-no. acc. to DIN EN 10204-2.2

1272888.0000

from G1 1/4: same as 1237463 but with additional:

- Valve body, cover, body screws acc. to DIN EN 10204 - 3.1
- Material quality proof for fluid contacted parts acc. to DIN EN 10204 2.2
- Function and leak test acc. to DIN EN 10204 - 3.1 leakage A acc. to DIN EN 12266-1

Dimensions

G1/4 ... 1
1/4 ... 1 NPT

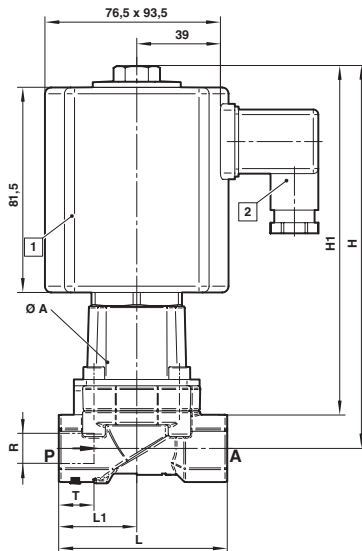

G1 1/4 ... 2
1 1/4 ... 2 NPT

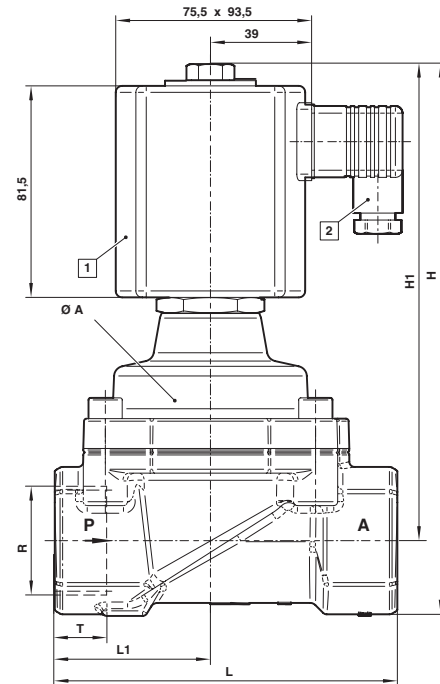

1 Solenoid rotatable 360°
 Socket turnable 4 x 90°
 (Socket included)

Port size R	A	H	H1	L	L1	T	Model
G1/4	44	163,5	152,5	60	27	12	8584000.840.xxxxx
1/4 NPT	44	163,5	152,5	60	27	10	8585000.840.xxxxx
G3/8	44	163,5	152,5	60	27	12	8584100.840.xxxxx
3/8 NPT	44	163,5	152,5	60	27	10,5	8585100.840.xxxxx
G1/2	44	166	152	67	31	14	8584200.840.xxxxx
1/2 NPT	44	166	152	67	31	13,5	8585200.840.xxxxx
G3/4	50	174	157,5	80	35,5	16	8584300.840.xxxxx
3/4 NPT	50	174	157,5	80	35,5	14	8585300.840.xxxxx
G1	62	184,5	164	95	44	18	8584400.840.xxxxx
1 NPT	62	184,5	164	95	44	17	8585400.840.xxxxx
G1 1/4	92	212,5	183,5	132	60	20	8584500.840.xxxxx
1 1/4 NPT	92	212,5	183,5	132	60	17	8585500.840.xxxxx
G1 1/2	92	212,5	183,5	132	60	22	8584600.840.xxxxx
1 1/2 NPT	92	212,5	183,5	132	60	17	8585600.840.xxxxx
G2	109	226,5	192	160	74	24	8584700.840.xxxxx
2 NPT	109	226,5	192	160	74	17,5	8585700.840.xxxxx

Note to Pressure Equipment Directive (PED):

The valves of this series up to and including DN 25 (G1) are according to Art. 4 § 3 of the Pressure Equipment Directive (PED) 2014/68/EU. This means interpretation and production are in accordance to engineers practice wellknown in the member countries. The CE-sign at the valve does not refer to the PED. Thus the declaration of conformity is not longer applicable for this directive.

For valves > DN 25 (G1) Art. 4 § (1) Letter d) applies:

The basic requirements of the Enclosure I of the PED must be fulfilled. The CE-sign at the valve includes the PED. A certificate of conformity of this directive will be available on request.

Note to Electromagnetic Compatibility Guideline (EEC):

The valves shall be provided with an electrical circuit which ensures the limits of the harmonised standards EN 61000-6-3 and EN 61000-6-1 are observed, and hence the requirements of the Electromagnetic Compatibility Guideline (2014/30/EU) satisfied.

Functional safety according to DIN EN 61508 (VDE0803) SIL:

Suitable for certain applications can only be evaluated through examination of each safety-related overall system with regard to the requirements of IEC 61508 / 61511.

Note to EAC marking:

The EAC-marked products comply with the applicable requirements stated in the technical regulations of the Eurasian Economic Union.