

- > **Port size: DN 8, G1/4 ... 1/2**
- > **High pressure solenoid valves**
- > **Solenoid interchangeable without tools (*Click-on*®)**
- > **Further customized**

solutions available upon request

Click-on®



8590178.9186



8590185.9841



Technical features

Medium:

For compressed natural gas (CNG)

Switching function:

Normally closed

Operation:

Indirectly solenoid actuated

Mounting position:

Optional, preferably solenoid vertical on top

Flow direction:

Determined

Port size:

G1/4, G3/8, G1/2

Operating pressure:

10 ... 320 bar (145 ... 4640 psi)

Leakage:

Internal Leakage acc. to DIN EN 12266-1 Leakage "C"
 External Leakage acc. to DIN EN 12266-1 Leakage "A"

Fluid temperature:

Solenoid 9841:

-20° ... +60°C (-4° ... +140°)

Solenoid 9186:

-20° ... +60°C (-4° ... +140°)

Ambient temperature:

Solenoid 9841:

-20° ... +50°C (-4° ... +122°)

Solenoid 9186:

-20° ... +40°C (-4° ... +104°)

Material:

Body: Brass

Seat seal: Polymer

Internal parts: Brass,

Stainless steel, Polymer

Installation of a 40 µm filter in front of the valve is required!

Technical data - standard models

Port size	Orifice (mm)	Flow kv value *1) (m³/h)	Operating pressure *2) *3) (bar)	Weight (kg)	Model Solenoid in V d.c./a.c.
G1/4	8	1,2	10 ... 320	2,2	8590371.9841.xxxxx
G1/4	8	1,2	10 ... 320	2,2	8590371.9186.xxxxx
G3/8	8	1,2	10 ... 320	2,2	8590185.9841.xxxxx
G3/8	8	1,2	10 ... 320	2,2	8590178.9186.xxxxx
G1/2	8	1,2	10 ... 320	2,2	8590337.9841.xxxxx
G1/2	8	1,2	10 ... 320	2,2	8590337.9186.xxxxx

xxxxx Please insert voltage and frequency codes

*1) Cv-value (US) ≈ kv value x 1,2

*2) Static test pressure PT = 480 bar

*3) Max. Differential pressure = 320 bar

Acc. to PED 97/23/EC and ATEX 94/9/EC!

Option selector

8590★★★★.★★★★.★★★★

Port size	Substitute
1/4	371
3/8	185*1) / 178*2)
1/2	337

*1) Only with Solenoid 9841.xxxxx
*2) Only with Solenoid 9186.xxxxx

Frequency	Substitute
See table frequency codes	xx
Voltage	Substitute
See Voltage Codes	xxx
Solenoid options	Substitute
Solenoid with 10 m cable ends Protection class according to - II 2 G Ex mb IIC T4 Gb - II 2 D Ex mb tb IIIC T130°C Db	9845
For d.c. with 1/2 - 14 NPT female thread and 460 mm flying leads Protection class acc. to ANSI/NEMA USA: FM approved (File-No. 2Z2A6.AE) Canada: CSA certified (File-No. LR 57643-6) Solenoids in temperature class T3C (160°C) are useable in Ex-areas (see table Ex-areas)	3826
For a.c. with integrated rectifier with 1/2 - 14 NPT female thread and 460 mm flying leads Protection class acc. to ANSI/NEMA USA: FM approved (File-No. 2Z2A6.AE) Canada: CSA certified (File-No. LR 57643-6) Solenoids in temperature class T3C (160°C) are useable in Ex-areas (see table Ex-areas)	3827
Solenoid with terminal box cable gland M20 x 1,5 cable clamp ø 5 ... 8 mm Protection class according to - II 2 G Ex e mb IIC T4/T5 Gb - II 2 D Ex tb IIIC T 130°C Db IP66 Ambient temperature: T4 -40 ... +50°C T5 -40 ... +40°C	428x
Solenoid with terminal box cable gland M20 x 1,5 (cable clamp ø 10 ... 14 mm) 1/2 ... 1/4 NPT (cable clamp ø 7,5 ... 11,9 mm) Protection class according to - II 2 G Ex d mb IIC T4/T5 Gb - II 2 D Ex tb IIIC T 130°C Ambient temperature: T4 -40 ... +50°C T5 -40 ... +40°C	468x

Standard solenoid systems

Voltage and Frequency Solenoid 9841					
Code Voltage	Code Frequency	Voltage	Frequency	Power consumption Inrush	Power consumption Holding
024	00	24 V d.c.	-	10,1 W	10,1 W
230	59	230 V a.c.	50 ... 60 Hz	9,2 VA	9,2 VA
Voltage and Frequency Solenoid 9186					
024	00	24 V d.c.	-	14 W	14 W
230	49	230 V a.c.	40 ... 60 Hz	16 VA	16 VA

Solenoid systems

ATEX category	Protection class	Solenoid	Standard voltages
II2GD	Ex mb IIC T4 Gb Ex mb tb IIIC T 130°C Db with 3 m connection cable	9841	24 V d.c., 110 V a.c., 230 V a.c.
II2GD	EEx me II T4, IP 65 Ex II 2 GD Junction box for cable diameter 5-10 mm cable entry M16 x 1,5	9186	24 V d.c., 110 V a.c., 230 V a.c.

Ex-areas

	Class	Division	Groups
Gases + fumes	I	1 and 2	A ... D
Dusts	II	1 and 2	E ... G
Fibres + fluffs	III	1 and 2	-

Electrical details for all solenoid systems

Voltage range	±10%
Duty cycle	100% ED
Protection class	EN 60529 IP65

According to DIN VDE 0580 at a solenoid temperature of +20°C.
At operating state temperature the input power of a coil decreases by up to ca. 30% due to physical reasons.

Dimensions

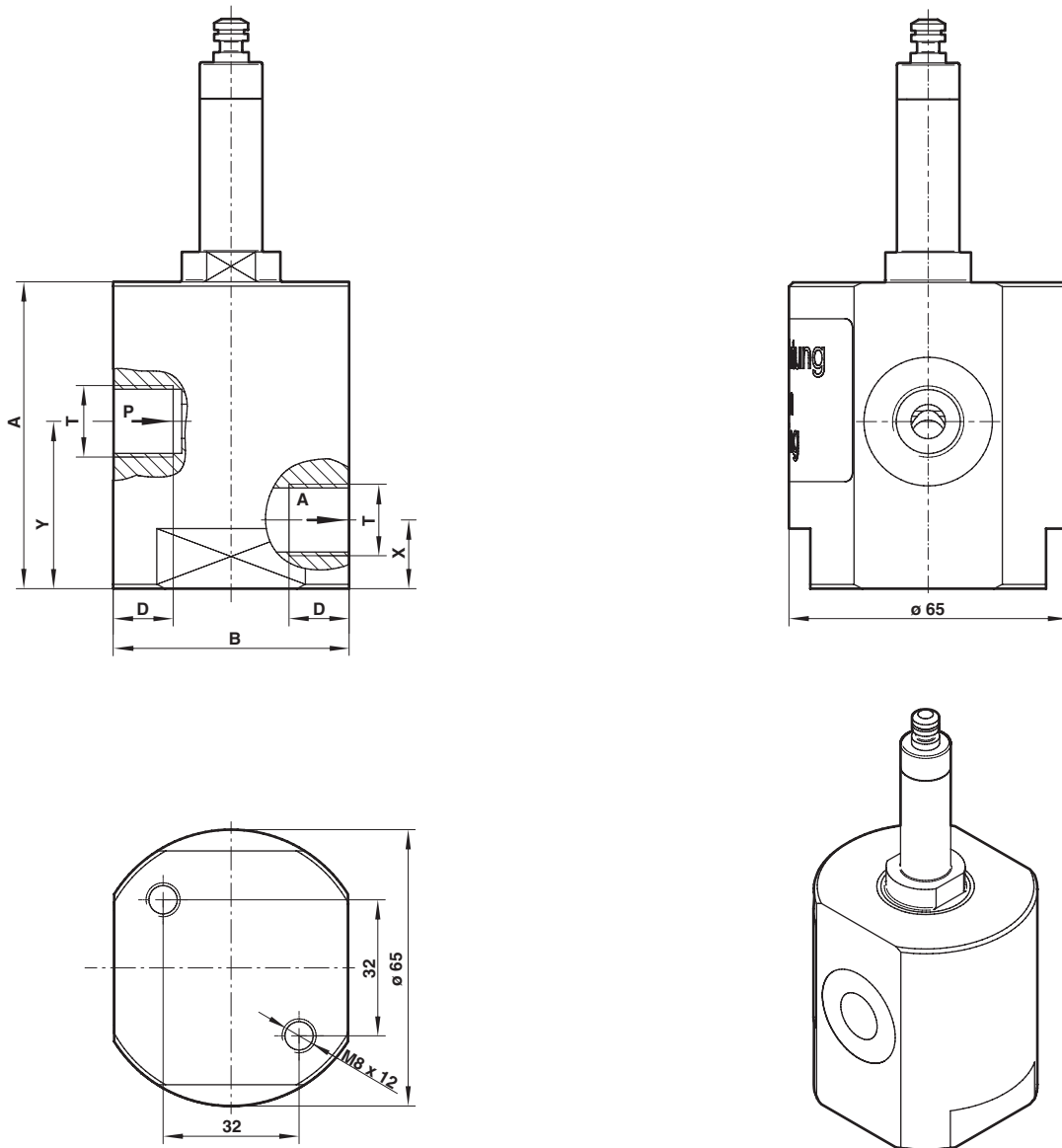
 Dimensions in mm
 Projection/First angle

Port size T	A (Block size)	B (Footage)	D (Depth of thread)	X (Distance from the bottom port A)	Y (Distance from the bottom port P)	Model
G1/4	74,5	55	13	16	42	8590371.xxxx.xxxxx
G3/8	71,5	55	14	16	39	8590178.9186.xxxxx
G3/8	71,5	55	14	16	39	8590185.9841.xxxxx
G1/2	74,5	57	15	16	42	8590337.xxxx.xxxxx

Dimensions Solenoids

Dimensions in mm
Projection/First angle



38xx

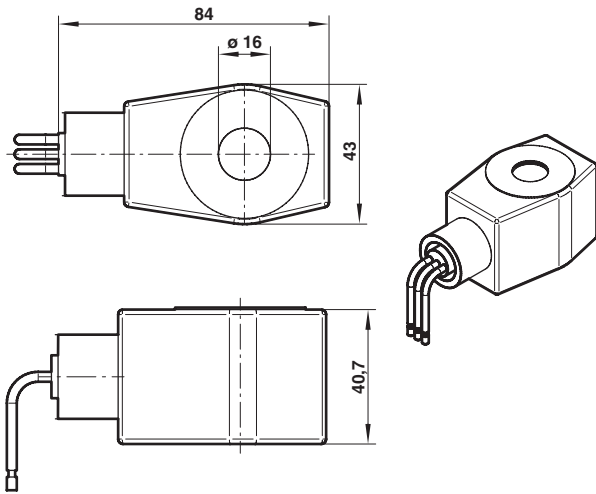

42xx

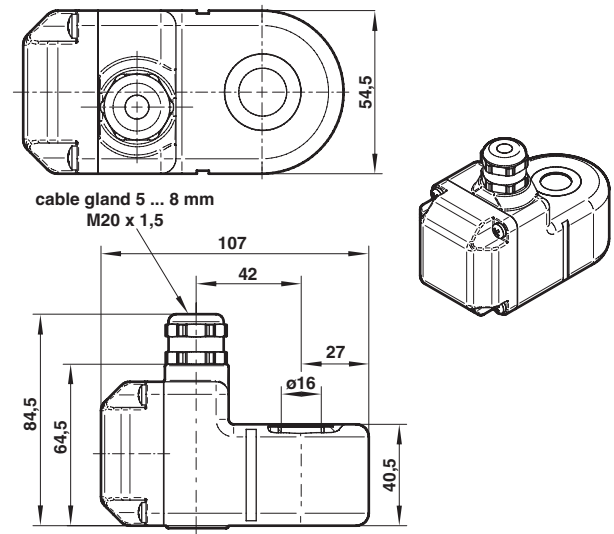

46xx

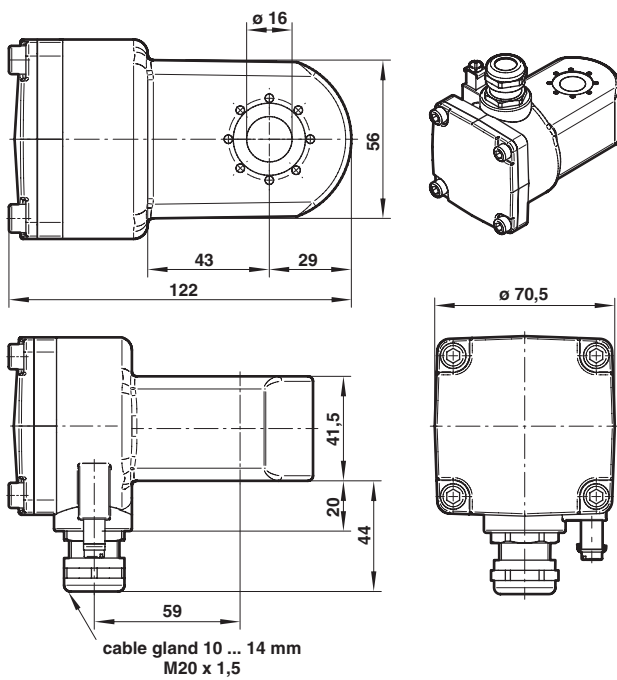

98xx

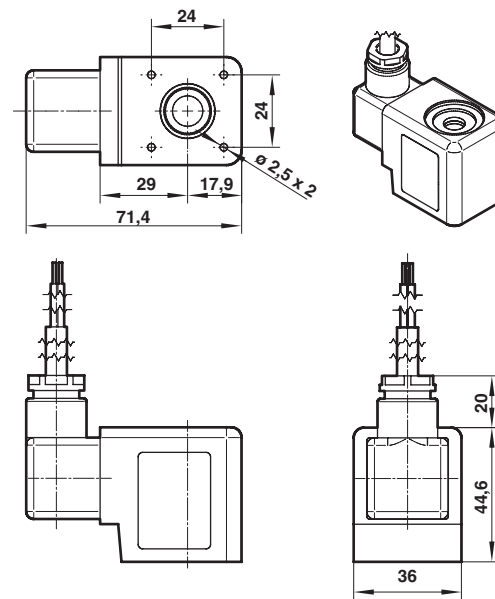

9186

