

Operation Manual
Electronic Pressure Sensor
54D-xxxxx-DD0-xx 2 x PNP



Content

1. Preliminary note	4
1.1 Symbols used	4
2 Safety information	4
3. Functions and features	4
4. Function	5
4.1 Processing of the measured signals	5
4.2 Switching function	5
4.3 Diagnostic function	6
5. Installation	6
5.1 Mounting accessories	6
5.2 DIN rail mounting	7
5.3 Panel mounting	7
6 Electrical connection	8
7. Operating and display elements	9
8. Menu	10
8.1 Menu structure	10
8.2 Explanation of the menu	11
9. Parameter setting	12
9.1 Parameter setting in general	12
9.2 Set output signals	14
9.2.1 Set the unit of measurement for system pressure	14
9.2.2 Set the output function	14
9.2.3 Set the switching limits (hysteresis function)	14
9.2.4 Set the switching limits (window function)	14
9.3 User settings (optional)	14
9.3.1 Set delay for the switching outputs	14
9.3.2 Set damping for the switching outputs	15
9.3.3 Configuration of the display	15
9.3.4 Zero-point calibration	16

9.4 Service functions	17
9.4.1 Read min/max values for the system pressure	17
9.4.2 Reset all parameters to factory setting	17
10. Operation	17
10.1 Read set parameters	17
10.2 Error indications	17
10.3 Setting ranges	18
11. Factory setting	18

1. Preliminary note

1.1 Symbols used

- ▶ Instructions
- > Reaction, result
- [...] Designation of keys, buttons or indications
- Cross-reference
-  Important note
Non-compliance can result in malfunction or interference.

2. Safety instructions

- *Please read this document prior to set-up of the unit. Ensure that the product is suitable for your application without any restrictions.*
- *If the operating instructions or the technical data are not adhered to, personal injury and/or damage to property can occur.*
- *Check the compatibility of the product materials with the media to be measured in all applications.*

3. Functions and features

The unit monitors the system pressure/differential pressure in compressed air networks and pneumatic systems of machines and plants.

-  Avoid static and dynamic overpressure exceeding the specified overload pressure by taking appropriate measures.

The indicated bursting pressure must not be exceeded.

Even if the bursting pressure is exceeded only for a short time, the unit may be destroyed.

ATTENTION: Risk of injury!

-  **Pressure Equipment Directive (PED):** The units comply with section 3, article (3) of the Directive 97/23/EC and are designed and manufactured for media of fluid group 2 (stable gases and non-superheated liquids) in accordance with the sound engineering practice.

Type of pressure: relative pressure

Order number	Measuring range		Permissible overpressure		Bursting pressure	
	bar	PSI	bar	PSI	bar	PSI
54D-V101...	-1...1	-14,5 ... 14,5	20	290	30	435
54D-V110...	-1 ... 10	-14,5 ... 145	20	290	30	435
54D-P016...	0 ... 16	0 ... 232	20	290	30	435

4. Function

4.1 Processing of the measured signals

- The unit displays the current system pressure.
- It generates 2 output signals according to the parameter setting.

OUT1	Switching signal for limit value
OUT2	2 options <ul style="list-style-type: none"> • Switching signal for system pressure limit value. • Diagnostic signal (output 1 is inactive in case of a fault).

4.2 Switching function

OUT1 changes its switching state if it is above or below the set switching limits (SP1, rP1). The following switching functions can be selected:

- Hysteresis function / normally open: $[ou1] = [Hno]$ (→ fig. 1)
- Hysteresis function / normally closed: $[ou1] = [Hnc]$ (→ fig. 1)

First the set point (SP1) is set, then the reset point (rP1) with the requested difference.

- Window function / normally open: $[ou1] = [Fno]$ (→ fig. 2).
- Window function / normally closed: $[ou1] = [Fnc]$ (→ fig. 2).

The width of the window can be set by means of the difference between FH1 and FL1. FH1 = upper value, FL1 = lower value.

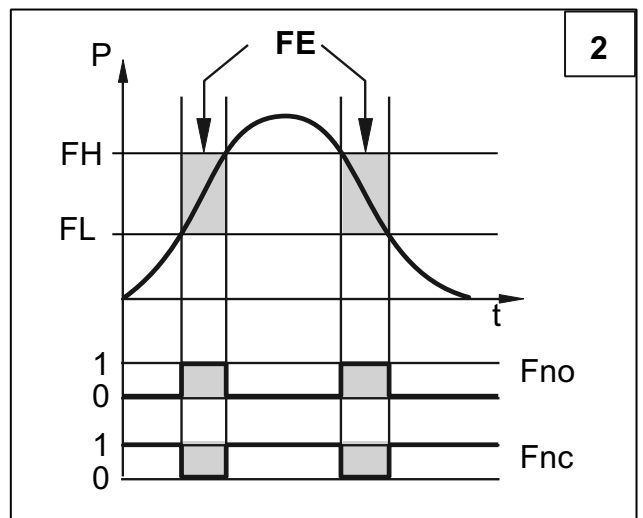
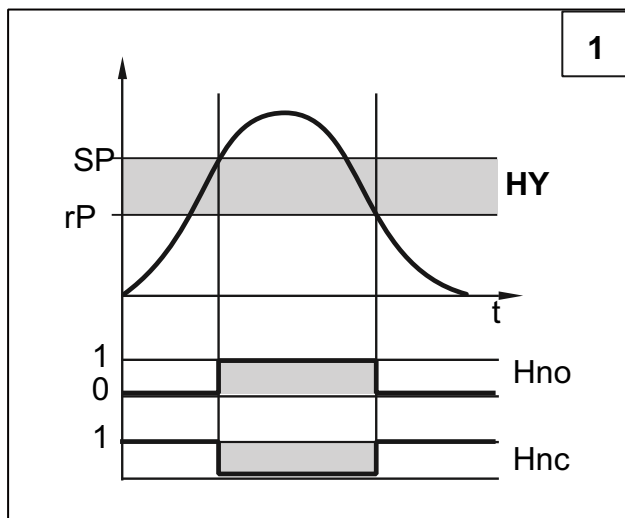

P = system pressure / differential pressure; HY = hysteresis; FE = window

4.3 Diagnostic function

Output 2 is used as diagnostic output based on the DESINA specification if [ou2] = [diA].

- If there is no fault, the output is switched and carries U_{b+} .
- In case of malfunctions in the following areas, the output is inactive:
 - short circuit in output 1.
 - EPROM function.
 - RAM function.
 - parameter setting.
 - processor function.

5. Installation

! Before installing and removing the unit: Make sure that no pressure is applied to the system.

▶ Screw the pressure connection or adapter G1/8 to the main pressure connection (1) and tighten:

➤ *Maximum tightening torque: 8 Nm.*

➤ *Maximum thread length: 7.5mm*

▶ If required: Screw the pressure connection or adapter M5 to the auxiliary pressure connection (2) and **slightly tighten** to avoid damage to the thread:

➤ *Maximum tightening torque: 2.5 Nm.*

➤ *Maximum thread length: 7.5mm*

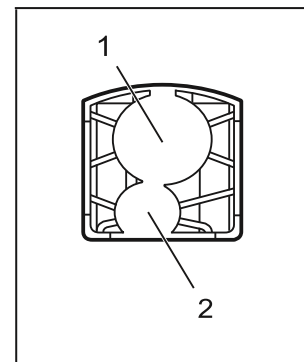

5.1 Mounting accessories

The following components can be supplied as accessories:

Mounting set for DIN rail mounting
(DIN rail TH 35-7.5 to EN 60715)

Order no.

54D-DINRAIL-CLIP

5.2 DIN rail mounting

DIN rail TH 35-7.5 to EN 60715

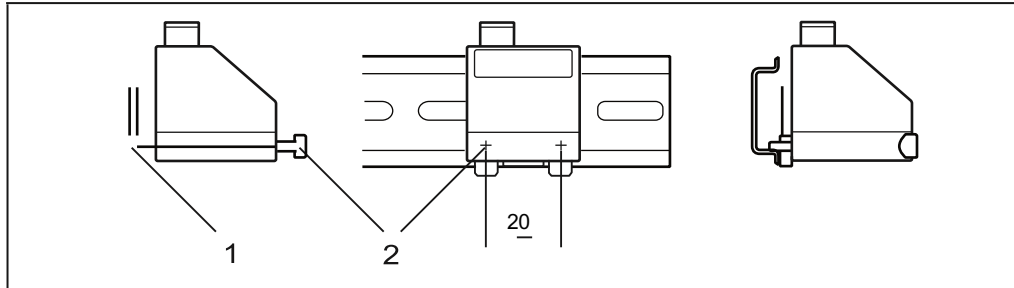

► Fix the mounting clip (1) with the M4 x 35 screws (2) to the flange.
Maximum tightening torque: 0,5 Nm.

► Hook the unit into the DIN rail and clip it into place.

Removal:

► Lever out the mounting clip with a screwdriver at the top or at the bottom and remove the unit.

5.3 Panel mounting

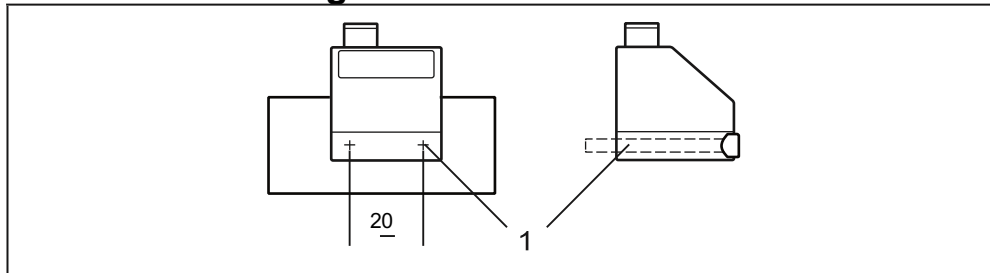

► Fix the unit with 2 M4 x 35 screws (1) (not included) to the rear panel. Maximum tightening torque: 0.5 Nm.

6. Electrical connection



The unit must be connected by a qualified electrician.

The national and international regulations for the installation of electrical equipment must be adhered to.

Voltage supply according to EN 50178, SELV, PELV.

- ▶ Disconnect power.
- ▶ Connect the unit as follows:

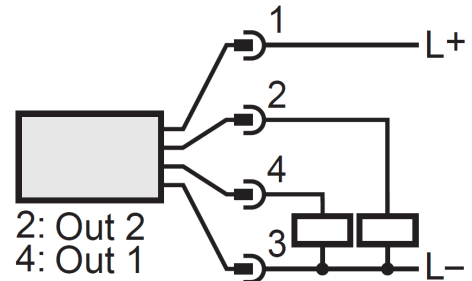

Pin 1	Ub+
Pin 3	Ub-
Pin 4 (OUT1)	Binary switching output pressure monitoring
Pin 2 (OUT2)	<ul style="list-style-type: none"> • binary switching output if [ou2] = [Hno], [Hnc], [Fno] or [Fnc] • diagnostic output if [ou2] = [diA]

7. Operating and display elements

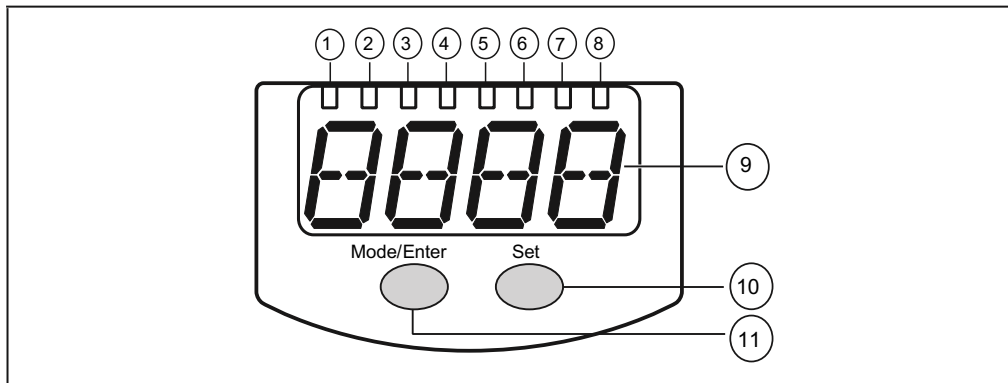

1 to 8: Indicator LEDs

LED 1 to LED 4	system pressure / differential pressure in the unit of measurement which is indicated on the label.
LEDs 5, 6	not used.
LED 7, 8	switching status of the corresponding output

9: Alphanumeric display, 4 digits

Display of the current system pressure.
Indication of the parameters and parameter values.

10: Set button

Setting of the parameter values (scrolling by holding pressed; incrementally by pressing once)

11: Mode/Enter button

Selection of the parameters and acknowledgement of the parameter values.

8. Menu

8.1 Menu structure

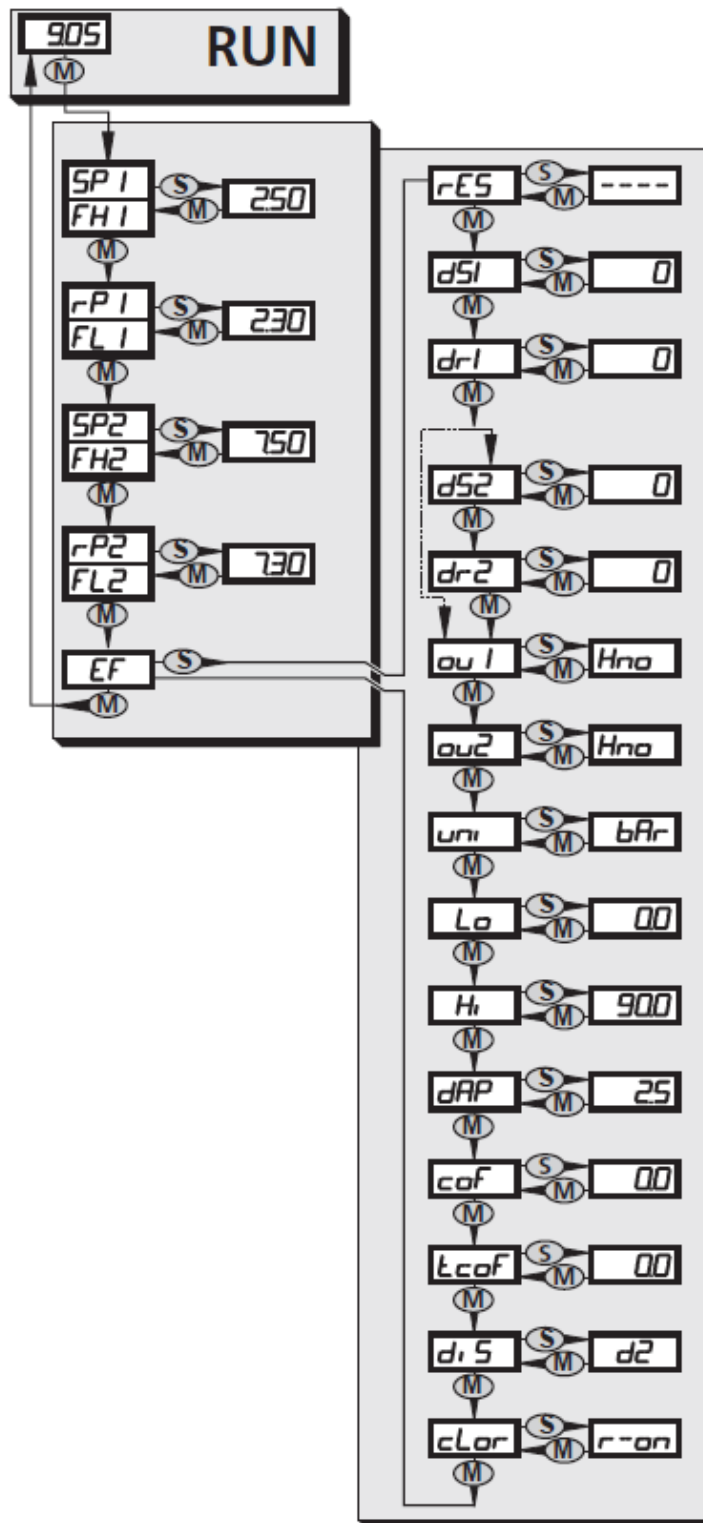

8.2 Explanation of the menu

SP1/rP1	Upper / lower limit value for system pressure at which OUT1 switches.
FH1/FL1	Upper / lower limit for the acceptable range (monitored by OUT1).
SP2/rP2	Upper / lower limit value for system pressure at which OUT2 switches.
FH2/FL2	Upper / lower limit for the acceptable range (monitored by OUT2).
EF	Extended functions / opening of menu level 2.
rES	Restore factory setting.
dS1	Time delay for SP1 / FH1.
dS2	Time delay for SP2 / FH2.
dr1	Time delay for rP1 / FL1
dr2	Time delay for rP2 / FL2
ou1	Output function for OUT1: Switching signal for the pressure limit values: hysteresis function [H ..] or window function [F ..], either normally open [. no] or normally closed [. nc].
ou2	Output function for OUT2: <ul style="list-style-type: none"> • Switching signal for the pressure limit values: hysteresis function [H ..] or window function [F ..], either normally open [. no] or normally closed [. nc]. • Diagnostic signal [ou2] = diA.
uni	Standard unit of measurement for system pressure.
Lo	Minimum value memory for system pressure.
Hi	Maximum value memory for system pressure.
dAP	Damping for the switching outputs.
coF	Manually enter the zero point calibration.
tcoF	Teach zero-point calibration.
SySP	Setting of the system pressure for optimised differential pressure measurement.
diS	Update rate and orientation of the display.
cLor	Colour of the digital display (permanent or alternating with switching status OUT1).

9. Parameter setting

During parameter setting the unit remains in the operating mode. It continues to monitor with the existing parameters until the parameter setting has been completed.

9.1 Parameter setting in general

Each parameter setting requires 3 steps:

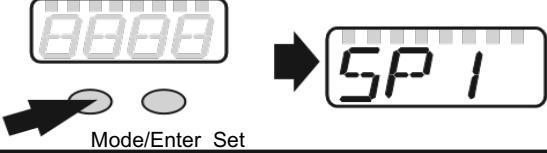
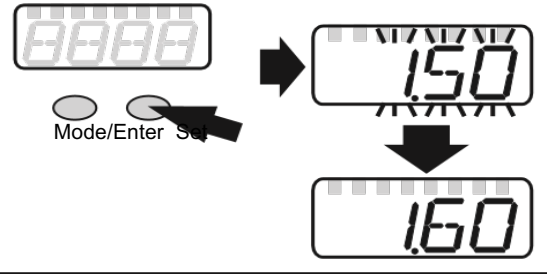
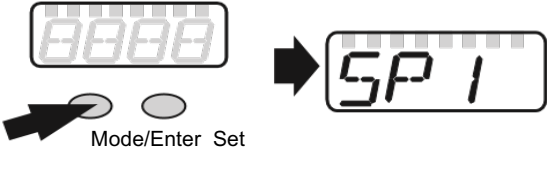
1	Select parameter ► Press [Mode/Enter] until the requested parameter is displayed.	
2	Set parameter value ► Press [Set] and keep it pressed. > Current setting value of the parameter flashes for 5 s. > After 5 s: setting value is changed: incrementally by pressing the button once or continuously by keeping the button	
Numerical values are incremented continuously. For reducing the value: let the display move to the maximum setting value. Then the cycle starts again at the minimum setting value.		
3	Acknowledge parameter value ► Briefly press [Mode/Enter]. > The parameter is displayed again. The new setting value is saved.	
Set other parameters: Start again with step 1.		
Finish parameter setting: ► Press [Mode/Enter] several times until the current measured value is displayed or wait for 15 s. > The unit exits the parameter setting mode.		

- If [C.Loc] is displayed when an attempt is made to modify a parameter value, parameters are read or written via the IO-Link interface (temporary locking).
- If [S.Loc] is displayed when an attempt is made to modify a parameter value, the sensor is locked via software. This locking cannot be removed on the sensor but unlocking has to be made via the IO-Link interface.

➔ *Change from menu level 1 to menu level 2:*

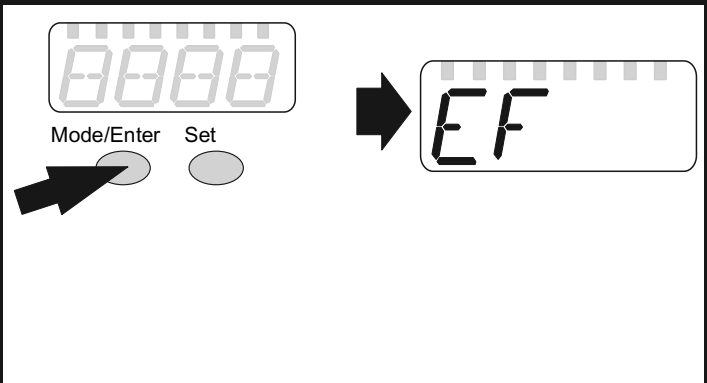
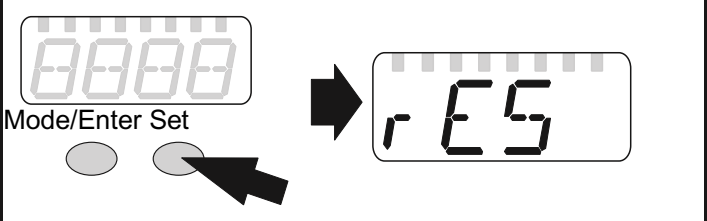
<ul style="list-style-type: none"> ▶ Press [Mode/Enter] until [EF] is displayed.. <p>If the submenu is protected with an access code, [cod1] is displayed.</p> <ul style="list-style-type: none"> ▶ Press [Set] and keep it pressed until the valid code no. is displayed. ▶ Briefly press [Mode/Enter]. <p>When delivered by ifm electronic: no access restriction.</p>	 <p>The diagram shows a sequence of two steps. In the first step, a digital display shows '0000'. Below it are two buttons labeled 'Mode/Enter' and 'Set'. An arrow points to the 'Mode/Enter' button. In the second step, the display shows 'EF'. An arrow points from the first step to the second.</p>
<ul style="list-style-type: none"> ▶ Briefly press [Set]. <p>> The first parameter of the submenu is displayed (here: [rES])</p>	 <p>The diagram shows a sequence of two steps. In the first step, a digital display shows '0000'. Below it are two buttons labeled 'Mode/Enter' and 'Set'. An arrow points to the 'Set' button. In the second step, the display shows 'rES'. An arrow points from the first step to the second.</p>

➔ *Locking / unlocking*

The unit can be locked electronically to prevent unintentional settings. Locking is also possible via an IO-Link capable parameter setting tool.

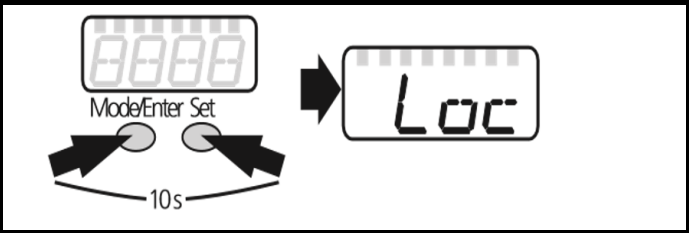
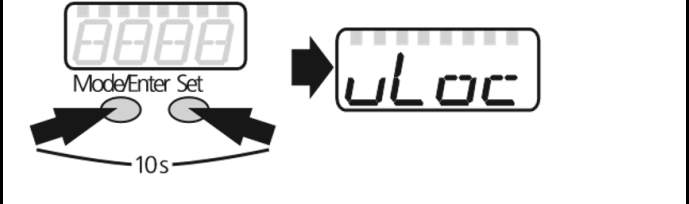
<ul style="list-style-type: none"> ▶ Make sure that the unit is in the normal operating mode. ▶ Press [Mode/Enter] + [Set] for 10 s. <p>> [Loc] is displayed.</p>	 <p>The diagram shows a sequence of two steps. In the first step, a digital display shows '0000'. Below it are two buttons labeled 'Mode/Enter' and 'Set'. Arrows point to both buttons, with a bracket underneath labeled '10s'. In the second step, the display shows 'Loc'. An arrow points from the first step to the second.</p>
<p>During operation: [Loc] is displayed for 15 s if you try to change parameter values.</p>	
<p>For unlocking:</p> <ul style="list-style-type: none"> ▶ Press [Mode/Enter] + [Set] for 10 s. <p>> [uLoc] is displayed.</p>	 <p>The diagram shows a sequence of two steps. In the first step, a digital display shows '0000'. Below it are two buttons labeled 'Mode/Enter' and 'Set'. Arrows point to both buttons, with a bracket underneath labeled '10s'. In the second step, the display shows 'uLoc'. An arrow points from the first step to the second.</p>

On delivery: not locked.

➔ *Timeout:*

If during parameter setting no pushbutton is pressed for 15 s, the unit exits the parameter

9.2 Set output signals

9.2.1 Set the unit of measurement for system pressure

▶ Select [Uni] and set the unit of measurement: [bAr], [kPa], [PSi], [inHg]	U71
---	-----

9.2.2 Set the output function

▶ Select [OU1] and set the function: [Hno] = hysteresis function/NO, [Hnc] = hysteresis function/NC, [Fno] = window function/NO, [Fnc] = window function/NC.	ou 1
--	------

9.2.3 Set the switching limits (hysteresis function)

▶ Make sure that for [ou1] the function [Hno] or [Hnc] is set.	SP 1
▶ Select [SP1] and set the value at which the output switches.	
▶ Select [rP1] and set the value at which the output switches off. rP1 is always smaller than SP1. The unit only accepts values which are lower than SP1.	rP 1

9.2.4 Set the switching limits (window function)

▶ Make sure that for [ou1] the function [Fno] or [Fnc] is set.	FH 1
▶ Select [FH1] and set the upper limit of the acceptable range.	
▶ Select [FL1] and set the lower limit of the acceptable range. FL1 is always lower than FH1. The unit only accepts values which are lower than the value for FH1.	FL 1

9.3 User settings (optional)

9.3.1 Set delay for the switching outputs

[dS1] = time delay for SP1 / FH1. If the system pressure exceeds SP1 or if the system pressure enters the acceptable range (window), the output changes the switching status when the time dS1 has elapsed.	dS 1
[dr1] = time delay for rP1 / FL1. If the system pressure falls below rP1 or if the system pressure leaves the acceptable range (window), the output changes the switching status when the time dr1 has elapsed.	dr 1
▶ Select [dS1] or [dr1] and set the value between 0 and 5000 ms in steps of 2 ms (at 0 the time delay is not active).	



9.3.2 Set damping for the switching outputs

<p>► Select [dAP] and set the value. dAP value = response time between pressure change and change of the switching status in milliseconds. The following fixed values can be set; they define the switching frequency (f in Hz) of the output:</p>										
dAP	6	10	30	60	100	250	500	1000	2000	
f	80	50	16	8	5	2	1	0,5	0,25	

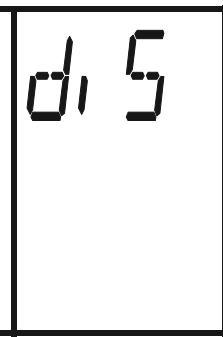
9.3.3 Configuration of the display

<p>► Select [diS] and set the update rate and orientation of the display: [d1]: update of the measured values every 50 ms. [d2]: update of the measured values every 200 ms. [d3]: update of the measured values every 600 ms. [Ph]: display of the pressure peaks remains for a short time (peak hold). [rd1], [rd2], [rd3]: display as for d1, d2, d3; rotated by 180°. [OFF]: the display is switched off in the operating mode.</p>		
<p>► Select [cLor] and define the colour of the digital display: [r-on]: display = red if output 1 is switched; display = green if output 1 is not switched. [G-on]: display = green if output 1 is switched; display = red if output 1 is not switched. [red]: the colour of the display is red / does not change. [Gren]: the colour of the display is green / does not change.</p>		

9.3.4 Zero-point calibration

<p>▶ Select [coF] and set a value between -2 % and 2 % of the measuring span. The internal measured value "0" is shifted by this value.</p>	
<p>As an alternative: Automatic adjustment of the offset in the range 0 bar \pm 2 % of the measuring span.</p> <p>▶ Make sure that there is no system pressure or that there is a differential pressure of 0 bar or that it is as close as possible to the 0 bar mark.</p> <p>▶ Press [Mode/Enter] until [tcoF] appears.</p> <p>▶ Press [Set] and keep it pressed.</p> <p>> The current offset value (in %) flashes briefly.</p> <p>▶ Release [Set].</p> <p>▶ Briefly press [Mode/Enter] (= to confirm the new offset value).</p> <p>Reset of the taught value:</p> <p>▶ Select [coF] and set the value [0].</p>	

9.4 Service functions

9.4.1 Read min/max values for the system pressure

- ▶ Select [Hi] or [Lo], briefly press [Set].
[Hi] = maximum value, [Lo] = minimum value.
- Delete memory:
 - ▶ Select [HI] or [LO].
 - ▶ Press [Set] and keep it pressed until [----] is displayed.
 - ▶ Briefly press [Mode/Enter].



9.4.2 Reset all parameters to factory setting

- ▶ Select [rES].
 - ▶ Press [Set] and keep it pressed until [----] is displayed.
 - ▶ Briefly press [Mode/Enter].
- We recommend noting down your own settings before carrying out a reset
(→ 11 Factory setting).



10. Operation

After power on, the unit is in the Run mode (= normal operating mode). It carries out its measurement and evaluation functions and provides output signals according to the set parameters. Operation indication → chapter 7 Operating and display elements.

10.1 Read set parameters

- ▶ Press [Mode/Enter] until the requested parameter is displayed.
- ▶ Briefly press [Set].

> The unit displays the corresponding parameter value for approx. 15 s. After another 15 s it returns to the Run mode.

10.2 Error indications

[OL]	Overload pressure (measuring range exceeded)
[UL]	Underload pressure (below measuring range)
[SC1]	Short circuit in OUT1*
[SC2]	Short circuit in OUT2*
[SC]	Short circuit in both outputs*
[CLoc]	Active IO-Link communication, setting buttons locked, parameter change is rejected.
[CLoc]	Setting buttons locked, parameter change is rejected, unlocking only possible via IO-Link interface.
[Err]	Flashing: internal fault

*The output concerned is switched off as long as the short circuit exists. The messages SC1 and Err are shown even if the display is switched off.

10.3 Setting ranges

		SPx / FHx		rPx / FLx		AP
		min	max	min	max	
54D-V101...	bar	-0,98	1,00	-0,99	0,99	0,01
	kPa	-98	100	-99	99	1
	PSI	-14,2	14,6	-14,4	14,4	0,2
	inHG	-28,8	29,7	-29,1	29,4	0,3
54D-V110...	bar	-0,90	10,00	-0,95	9,95	0,05
	kPa	-90	1000	-95	995	5
	PSI	-13	145	-14	144	1
	inHG	-26	296	-28	294	2
54D-P016...	bar	0,1	16	0,05	15,95	0,05
	kPa	10	160	0,5	159,5	5
	PSI	1,45	232	0,7	230	1
	inHG	2,9	472	1,47	471	2

11. Factory setting

	Werkseinstellung	Benutzer-Einstellung / Kommentare
SP1 / FH1	25% VMR*	
rP1 / FL1	23% VMR*	
ou1	Hno	
ou2	Hno	
SP2/FH2	75% VMR*	
rP2/FL2	73% VMR*	
coF	0,0	
SySP	0,0	
dS1	0	
dr1	0	
dS2	0	
dr2	0	
dAP	6	
diS	d2	
uni	bAr	
cLor	r-on	

* = the indicated percentage of the final value of the measuring range (VMR) of the corresponding sensor is set in bar

The data specified above only serve to describe the product.

No statements concerning a certain condition or suitability for a certain application can be derived from our information.

The given information does not release the user from the obligation of own judgement and verification.

It must be remembered that our products are subject to a natural process of wear and aging.

© This document, as well as the data, specifications and other informations set forth in it, are the exclusive property of Norgren GmbH.

Without their consent it may not be reproduced or given to third parties.

Subject to modifications.

Printed in Germany.

These instructions were originally generated in German. These instructions were originally generated in German.

Order no. **7503761000000050**