

- Non-relieving models for air and water service
- Relieving models for air service allow reduction of outlet pressure even when the system is dead-ended
- R14 has aluminum body and bonnet
- R16 has brass body and bonnet
- Factory preset, tamper resistant pressure setting
- Non-repairable

Ordering Information. Models listed are relieving type for compressed air service with PTF threads and with gauge ports

Port	Model	Flow [†] scfm (dm ³ /s)	Flow ^{††} U.S. gpm (lpm)	Weight lb (kg)
1/8" PTF	R14-100-R** A	12 (5.7)	1.3 (4.9)	0.2 (0.09)
1/8" PTF	R16-100-R** A	12 (5.7)	1.3 (4.9)	0.7 (0.32)
1/4" PTF	R14-200-R** A	12 (5.7)	1.3 (4.9)	0.2 (0.09)
1/4" PTF	R16-200-R** A	12 (5.7)	1.3 (4.9)	0.7 (0.32)

† Approximate flow with 100 psig (7 bar) inlet pressure, 80 psig (5.5 bar) set pressure and a 15 psig (1 bar) droop from set.

†† Approximate flow with 100 psig (7 bar) inlet pressure, 60 psig (4 bar) set pressure and a 15 psig (1 bar) droop from set.

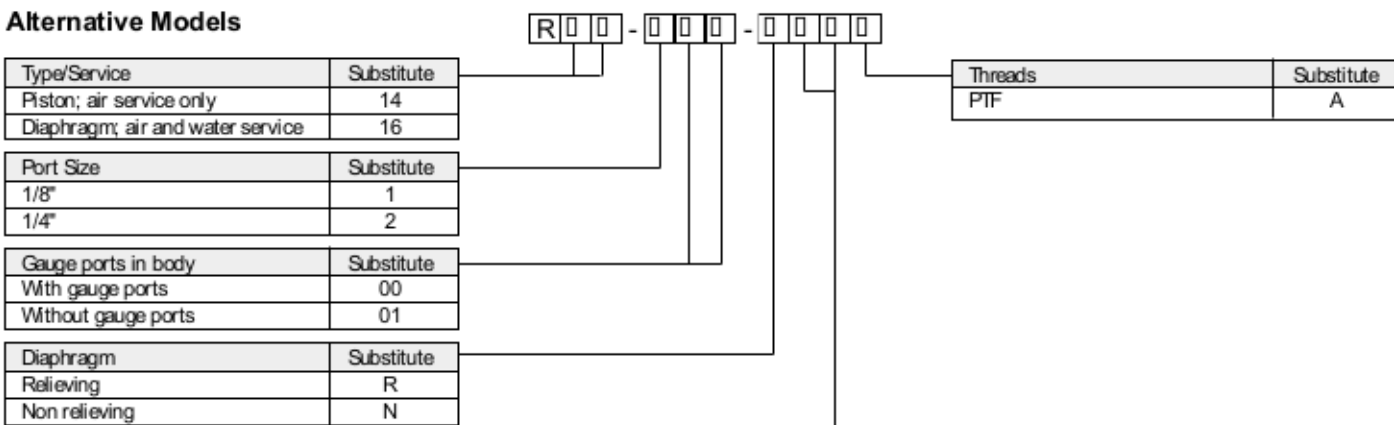
Alternative Models

** The 8th and 9th positions of the model number contain the **Modified Outlet Pressure Setting**. The **Modified Outlet Pressure Setting** is the desired outlet pressure, modified to allow for inlet pressures other than 100 psig, and for flows other than zero. Insert the modified outlet pressure setting in positions 8 and 9 as described below.

1. Write down the desired outlet pressure and the flow through the regulator. EXAMPLE 30 psig outlet pressure at 10 scfm flow.

2. Modifications for inlet pressures other than 100 psig:

If inlet pressure exceeds 100 psig*, add 1 psig to the desired outlet pressure for each 20 psig the inlet pressure is above 100 psig*.

EXAMPLE: If the inlet pressure is 180 psig, add 4 to the desired outlet pressure. Following through with the example in step 1, add 4 to 30 for a modified outlet pressure setting of 34 psig.

If inlet pressure is less than 100 psig*, subtract 1 psig from the desired outlet pressure for each 20 psig the inlet pressure is below 100 psig*.

EXAMPLE: If the inlet pressure is 60 psig, subtract 2 from the desired outlet pressure. Following through with the example in step 1, subtract 2 from 30 for a modified outlet pressure setting of 28 psig.

3. Modifications for flows other than zero:

Determine the pressure drop from the appropriate flow curve above. Add the pressure drop to the modified outlet pressure setting.

EXAMPLE: If the desired outlet pressure is 30 psig at a flow of 10 scfm, add 10 to the modified outlet pressure setting. The quantity of 10 is the difference between the outlet pressure (30 psig) at the desired flow (10 scfm) and outlet pressure (40 psig) at no flow. See dashed lines on the air flow curve for example. Following through with the first example in Step 2 above, add 10 to the 34 to obtain a modified outlet pressure setting of 44. Enter 44 in the 8th and 9th positions of the model number.

* 125 psig for outlet pressure settings of 95 through 99 psig.



Technical Data

Fluid

- R14: Compressed air
- R16: Water and compressed air

Maximum pressure: 400 psig (27 bar)

Operating temperature

- Water service: 35° to 175°F (2° to 79°C)†
- Air service: -30° to 175°F (-34° to 79°C) *†

* Air supply must be dry enough to avoid ice formation at temperatures below 35°F (2°C).

Type

- R14: Piston, relieving or non-relieving
- R16: Diaphragm, relieving or non-relieving

Typical flow for water service at 100 psig (7 bar) inlet pressure, 60 psig (4 bar) set pressure and a droop of 15 psig (1 bar) from set: 1.3 U.S. gpm (4.9 liters per minute)

Typical flow for compressed air service at 100 psig (7 bar) inlet pressure, 80 psig (5.5 bar) set pressure and a droop of 15 psig (1 bar) from set: 12 scfm (5.7 dm³/s)

Gauge ports: 1/8" PTF

Factory preset outlet pressure settings: 0,2 to 6,8 bar (3 to 99 psig)

Outlet pressure tolerance:

Outlet pressure setting - psig (bar)	Tolerance - psig (bar) **
3 to 20 psig (0.21 to 1.38 bar)	± 1.0 psig (0.07 bar)
21 to 50 psig (1.45 to 3.45 bar)	± 2.0 psig (0.14 bar)
51 to 99 psig (3.52 to 6.84 bar)	± 3.0 psig (0.21 bar)

** When outlet pressure is preset at the factory, the following conditions exist

Flow thru regulator: No flow

Inlet pressure:

- 100 psig (6.9 bar) for outlet pressures up through 95 psig (6.6 bar)
- 125 psig (8.6 bar) for outlet pressures of 96 through 99 psig (6.7 through 6.8 bar)

Materials

- Body and bonnet
- R14: Aluminum
- R16: Brass
- Valve: Brass
- Valve seat: Acetal resin
- Elastomers: Nitrile

Typical Performance Characteristics

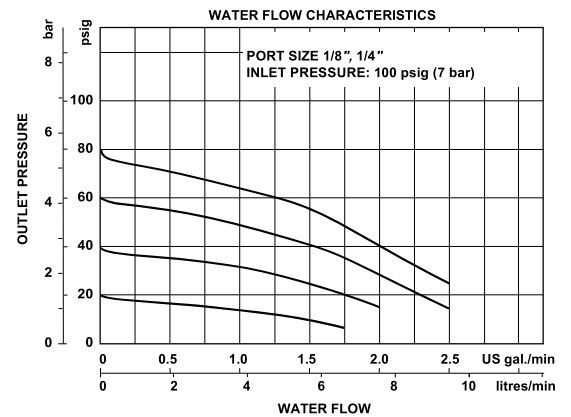
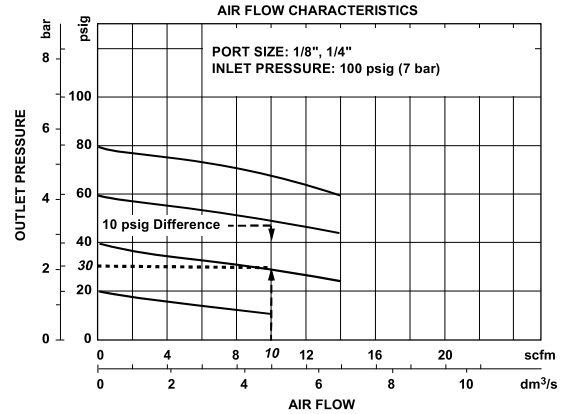

All Dimensions in Inches (mm)

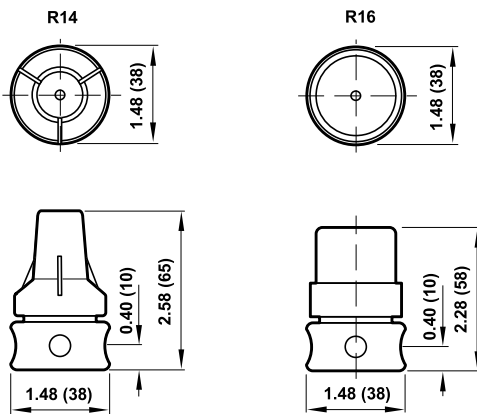

ISO Symbols

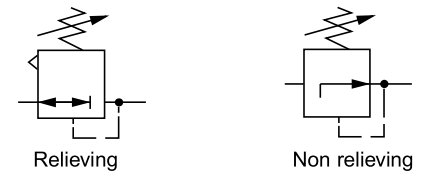

† R16 brass bonnet & body combination max temperature 200°F

See Section ALE-24 for Accessories