

2/2-way valves ND 15 to 100



For aggressive fluids
 Pressure actuated by external fluid
 Diaphragm valves
 Connection adhesive / welded ends
 Operating pressure 0 to 10 bar, see characteristic data



Publication 7501576.06.06.96
 Catalogue index
A13
 83 510 series

Description (standard valve)

Solenoid valve for acid resp. base aggressive gaseous and liquid fluids

Flow direction: Optional
 Mounting position: Optional

Flow fluid range
 Fluid temperature: max +60°C
 Ambient temperature: max +40°C
 Material Body: PVC
 Seat seal: EPDM

Pilot fluid: gaseous and liquid neutral fluids
 Viscosity max. 40 mm²/s (cSt)
 Temperature max. +40°C

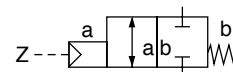

Features

- Suitable for high viscosity and contaminated flow fluids
- High flow rate
- Special seal for oil

Switching function:
 Normally closed

Characteristic data

ND [mm]	Operating pressure with gaseous and liquid fluids up to 400 mm ² /s (cSt) [bar]		Pilot pressure [bar]		k _v -value ¹⁾ (Base m ³ /h)	Weight [kg]	Section no	Dimension table no	Cat. no. XX XXX XX.XXXX
	min.	max.	min.	max.					
15	0	10	3	6	5.6	1.8	01	01	83 512 00.0000
20	0	10	3	6	8.2	1.8	01	02	83 513 00.0000
25	0	10	3	6	10.5	1.8	01	03	83 514 00.0000
32	0	10	3	6	18.0	4.0	01	04	83 515 00.0000
40	0	10	3	6	25.0	4.0	01	05	83 516 00.0000
50	0	10	3	6	46.0	7.4	01	06	83 517 00.0000
65	0	6	3	6	78.0	16.3	02	07	83 518 00.0000
80	0	6	3	6	120.0	16.3	02	08	83 519 00.0000
100	0	6	3	6	189.0	24.5	03	09	83 520 00.0000

IMI Norgren Buschjost GmbH + Co. KG

PO Box 10 02 52-53
 D-32502 Bad Oeynhausen

Tel +49 (0) 57 31 79 10
 Fax +49 (0) 57 31 79 11 79

<http://www.buschjost.com>
 e-mail:mail@buschjost.de

Further models

available at extra cost

- XX XXX **01**.XXXX Normally open,
operating pressure 5 to 6 bar
- XX XXX **03**.XXXX Seat seal FPM
- XX XXX **06**.XXXX Seat seal PTFE
- XX XXX **57**.XXXX Electrical position indicator
for AC/DC

- XX XXX **58**.XXXX Electrical position indicator only
up to 30 V DC
- **On request** Further versions,
screw boot or adhesive flanges

A 3/2 way solenoid valve can be fitted at the pilot connection Z.

Required parts ND 15 to 50	Cat. no.
1 pc. 3/2 way solenoid valve	84 954 75.0164 DC 84 954 75.0165 AC

Technical details see publication
7502723.06.XX.XX

Required parts ND 65 to 100	Cat.no.
1 pc. 3/2 way solenoid valve for gaseous fluids or 1 pc. 3/2 way solenoid valve for liquid fluids	80 207 50.0201 24 011 03.0801
1 pc. connection complete	05 626 10.0000

Technical details see publication
7501049.06.XX.XX resp. 750 0189.06.XX.XX

Sections

01

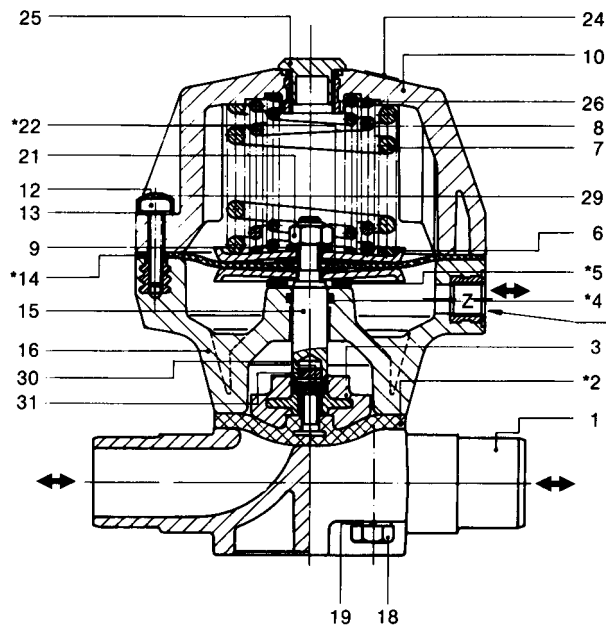

- | | |
|----------------------------|--------------------|
| 1 Valve body | *14 Diaphragm |
| *2 Shut diaphragm | 15 Spindle |
| 3 Thrust collar | 16 Base complete |
| *4 Quad-seal-ring | 18 Screw |
| *5 Rubber washer | 19 Spring washer |
| 6 Diaphragm disk | 21 Uni-stop-nut |
| 7 Pressure spring | *22 Gasket |
| 8 Pressure spring | 24 Material plate |
| 9 Washer | 25 Sealing cap |
| 10 Hood complete | 26 Pressure spring |
| 12 Oval head
cap screw | 29 Cover |
| 13 Fan type lock
washer | 30 Straight pin |
| | 31 Tappet |

02

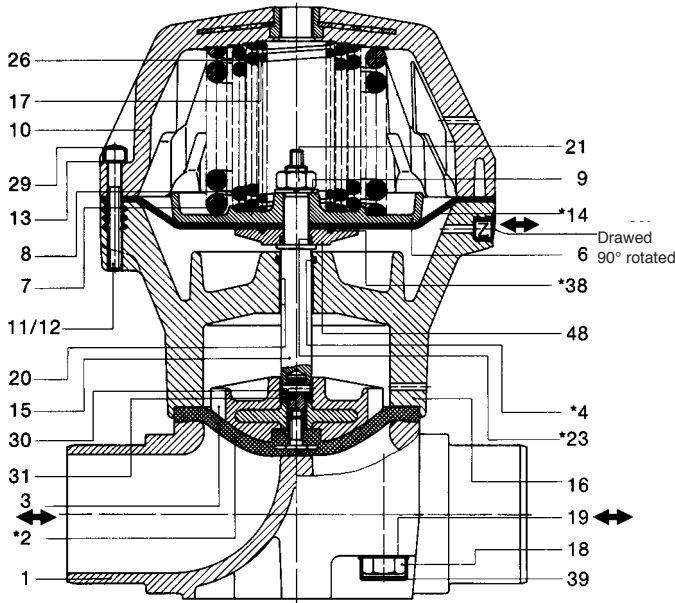

- | | |
|---------------------|--------------------|
| 1 Valve body | 17 Pressure spring |
| *2 Shut diaphragm | 18 Hexagon screw |
| 3 Thrust collar | 19 Washer |
| *4 Quad-seal-ring | 20 DU bushing |
| 6 Diaphragm plate | 21 Hexagon nut |
| 7 Pressure spring | 22 Gasket |
| 8 Pressure spring | *23 O-ring |
| 9 Washer | 26 Pressure spring |
| 10 Cover complete | 29 Cap |
| 11 Hexagon screw | 30 Straight pin |
| 12 Hexagon screw | 31 Tappet |
| 13 Washer | *38 O-ring |
| *14 Diaphragm | 39 Cap |
| 15 Spindle complete | 48 Washer |
| 16 Base complete | |

03

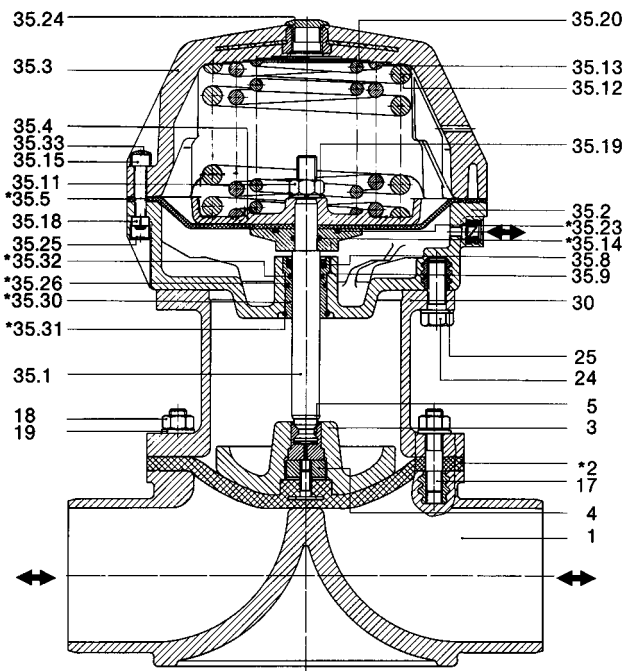

- | | |
|-------------------------|-----------------------|
| 1 Valve body | 35.11 Hexagon nut |
| *2 Shut diaphragm | 35.12 Pressure spring |
| 3 Thrust collar | 35.13 Pressure spring |
| 4 Tension nut | *35.14 O-ring |
| 5 Shell | 35.15 Hexagon screw |
| 17 Stud | 35.18 Hexagon nut |
| 18 Hexagon nut | 35.19 Plain washer |
| 19 Plain washer | 35.20 Pressure spring |
| 24 Hexagon nut | *35.23 O-ring |
| 25 Plain washer | 35.24 Sealing cap |
| 30 Adaptor | 35.25 Sealing cap |
| 35.1 Spindle | *35.26 O-ring |
| 35.2 Base | *35.30 Guide bush |
| 35.3 Upper part | *35.31 Snap ring |
| 35.4 Diaphragm disk | *35.32 Quad-seal-ring |
| *35.5 Control diaphragm | 35.33 Cover |
| 35.8 Lip ring | |
| 35.9 Washer | |

* These individual parts form a complete wearing unit.
When ordering spare parts please state Cat.no. and series no.

Dimensions

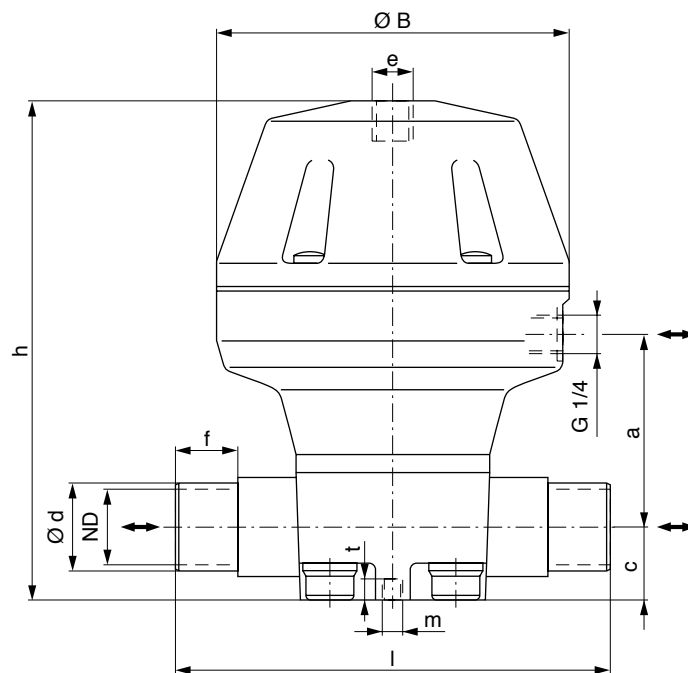

ND 15 to 80 = 2 fastening threads „m“
 ND 100 = 4 fastening threads „m“

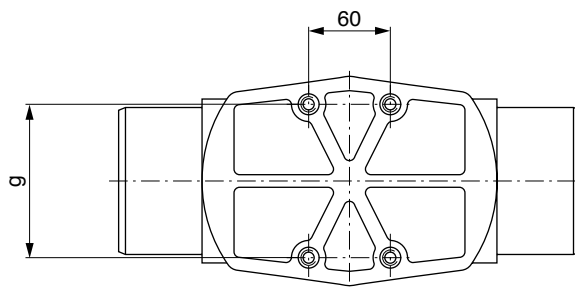

Filling volume of actuator:

Ø B 126 = 0.15 NI

Ø B 155 = 0.35 NI

Ø B 210 = 1.20 NI

Ø B 258 = 2.10 NI (ND 65 resp. 80)

Ø B 258 = 2.40 NI (ND 100)

Dimension table no.	ND	a	Ø B	c	Ø d	e	f	g	h	l	m	t
01	15	66	126	26	20	M 16x1	16	25	148	124	M 6	12
02	20	66	126	26	25	M 16x1	19	25	148	144	M 6	12
03	25	66	126	26	32	M 16x1	22	25	148	154	M 6	12
04	32	103	155	40	40	M 16x1	26	44.5	203	174	M 8	18
05	40	103	155	40	50	M 16x1	31	44.5	203	194	M 8	18
06	50	125	210	40	63	M 16x1	38	44.5	254	224	M 8	18
07	65	187	258	55	75	M 22x1.5	44	100	325	284	M 12	22
08	80	187	258	55	90	M 22x1.5	51	100	325	300	M 12	22
09	100	268	258	65	110	M 22x1.5	61	120	416	340	M 10	20