



- > Port size: DN 65 ... 100, flange connection PN 16
- > Flat piston valve
- > High flow rate
- > Damped operation
- > Valve works without minimum pressure differential



OBSOLETE DOCUMENT
Technical Reference Only



Technical features

Medium:

Air, water, oil

Switching function:

Normally closed

Operation:

Solenoid actuated, with forced lifting

Mounting:

Solenoid vertical on top

Flow direction:

Determined

Port size:

Flange PN 16, DN 65 ... DN 100

Operating pressure:

0 ... 16 bar (0 ... 232 psi)

Fluid temperature:

-10 ... +90°C (+14 ... +194°F)

Ambient temperature:

-10 ... +50°C (+14 ... +122°F)

Material:

Body: Grey cast iron

Seat seal: NBR

Cover: Grey cast iron

Internal parts: Stainless steel, brass, gun metal

For contaminated fluids insertion of a strainer is recommended.

Technical data - standard models

Symbol	Orifice (mm)	Flow kv value *1) (m³/h)	Operating pressure *2) (bar)	Weight (kg)	Model Solenoid in V d.c.	Model Solenoid in V a.c.
	65	67	0 ... 16	34	8410800.9501.xxxxx	8410800.9504.xxxxx
	80	94	0 ... 16	42,4	8410900.9501.xxxxx	8410900.9504.xxxxx
	100	144	0 ... 16	61,2	8411000.9501.xxxxx	8411000.9504.xxxxx

xxxxx Please insert voltage and frequency codes

*1) Cv-value (US) ≈ kv value x 1,2

*2) For gases and liquid fluids up to 40 mm²/s (cSt)

Option selector

8410★★★★★★★★

Port size	Substitute
DN 65	8
DN 80	9
DN 100	10
Valve options	Substitute
Normally open (NO)	01
Manual override	02
Seat seal FPM, Fluid temperature -10 ... +110°C (+14 ... 230°F)	03
Seat seal PTFE, Fluid temperature -10 ... +110°C (+14 ... 230°F), Leakage rate E acc. to EN 12266-1	06
Seat seal EPDM, Fluid temperature -10 ... +110°C (+14 ... 230°F)	14
Normally open (NO), Seat seal FPM, Fluid temperature -10 ... +110°C (+14 ... 230°F)	17
Electrical position indicator with two solenoid switches, Ex	40
Electrical position indicator with two solenoid switches	41

Frequency	Substitute
See table frequency codes	xx
Voltage	Substitute
See Voltage codes	xxx
Solenoid options	Substitute
DN 65 ... 100 Solenoid in V d.c.	9501
DN 65 ... 100 Solenoid in V a.c.	9504

Standard solenoid systems

Voltage and Frequency Solenoid 9501/9504					
Code Voltage	Code Frequency	Voltage	Frequency	Power consumption	
				Inrush	Holding
024	00	24 V d.c.	-	80 W	80 W
024	49	24 V a.c. *1)	40 ... 60 Hz	89 VA	89 VA
42	49	42 V a.c. *1)	40 ... 60 Hz	89 VA	89 VA
110	49	110 V a.c. *1)	40 ... 60 Hz	89 VA	89 VA
230	49	230 V a.c. *1)	40 ... 60 Hz	89 VA	89 VA

*1) AC only with rectifier plug

Electrical details for all solenoid systems

Design	DIN VDE 0580
Voltage range	±10%
Duty cycle	100% ED
Protection class	EN 60529 IP65
Socket	Form A acc. to DIN EN 175301-803 (included)

According to DIN VDE 0580 at a solenoid temperature of +20°C.
At operating state temperature the input power of a coil decreases by up to ca. 30% due to physical reasons.



Additional solenoid systems

ATEX category	Protection class	Solenoid	Standard voltages
II2GD	II 2 G Ex e mb II T3...T4 II 2 D Ex tD A21 IP65 T140°C	9540	24 V d.c., 110 V a.c., 230 V a.c.

Attention!

The conditions imposed on the Ex approvals lead to reduction of the permissible standard temperature ranges in the cases of explosion protected solenoids.

Further versions on request!

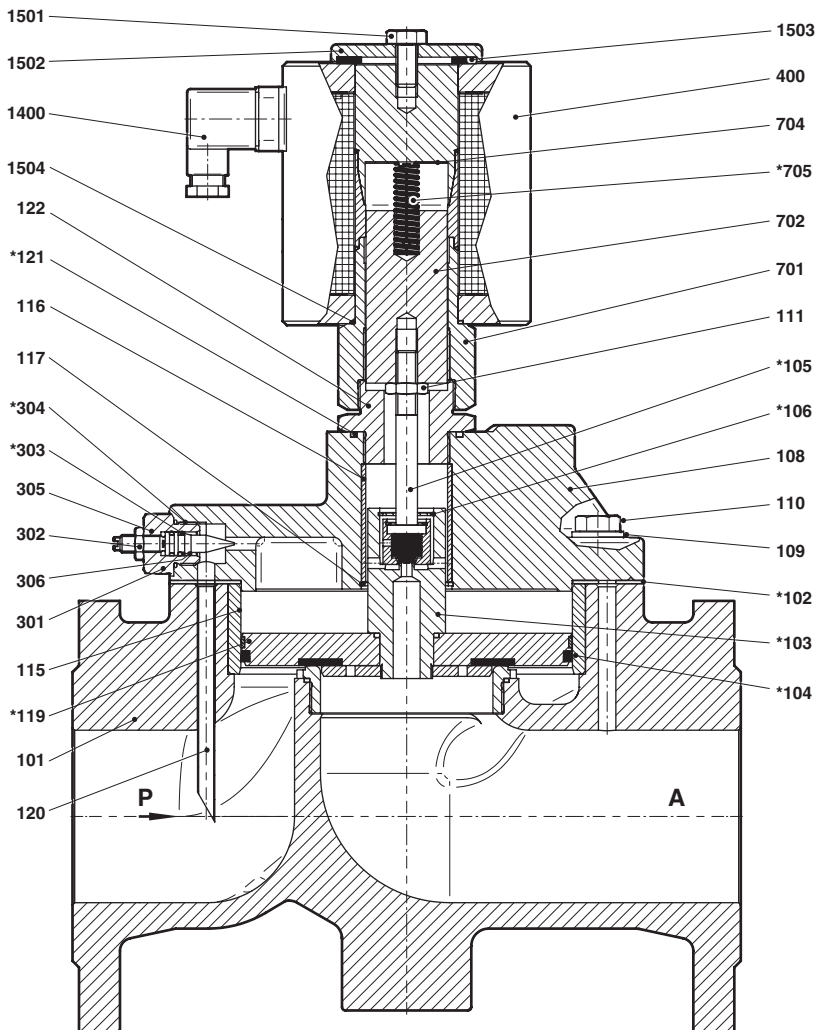
Section View
DN 65 ... 100

No.	Description
101	Valve body
*102	Gasket
*103	Valve piston
*104	Grooved ring
*105	Valve spindle
*106	Locking ring
108	Body cover
109	Spring washer
110	Hexagon screw
111	Hexagon nut
115	Bushing
116	Bushing
117	Snap ring
*119	Guide foil
120	Tube
*121	O-ring
122	Screw piece
301	Screw piece
302	Valve spindle
*303	O-ring
*304	O-ring
305	Hexagon nut
400	Solenoid
701	Core tube
702	Core
704	Round plate
*705	Pressure spring
1400	Socket (included)
1501	Hexagon screw
1502	Round plate
1503	Gasket
1504	O-ring

* These individual parts form a complete wearing unit. When ordering spare parts please state Model No. and Series No.

To avoid high shock pressure, you can control the closing time with the adjusting stem pos. 301.

Turning clockwise increase restriction and slows down closing time. A totally closed restriction would result in an malfunction.

Dimensions

DN 65 ... 100

Dimensions in mm
Projection/First angle

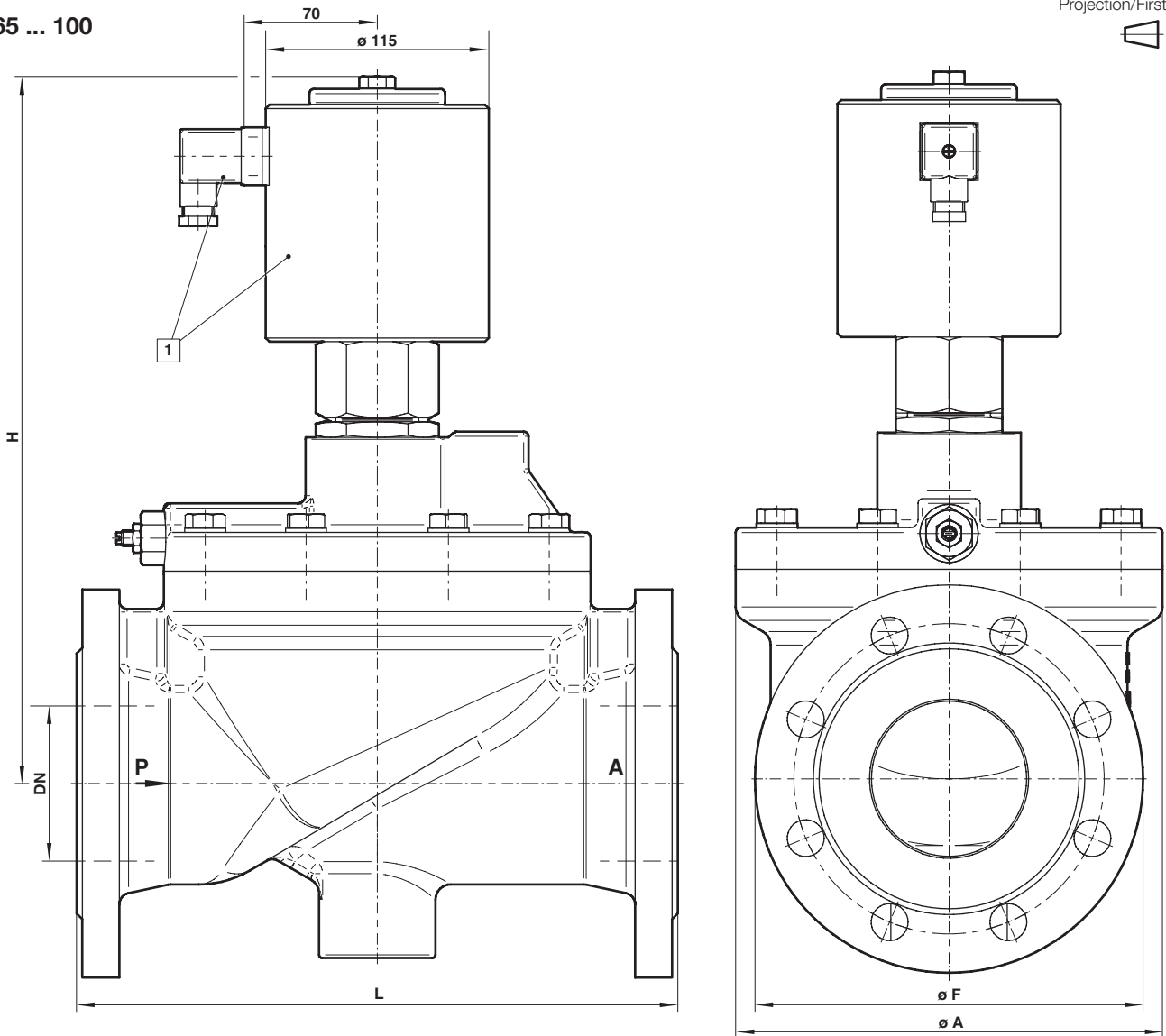

1 Solenoid rotatable 360°
Socket turnable 4 x 90°
(Socket included)

Orifice (mm)	L	ø A	H	ø F	Model
65	290	195	340	185	8410800.950x.xxxxx
80	310	220	360	200	8410900.950x.xxxxx
100	350	260	390	220	8411000.950x.xxxxx

Contact face acc. to DIN EN 1092-1/B

Note to Pressure Equipment Directive (PED):

For valves > DN 25 (cf. [1] Art. 3 § [1] No.1.4 applies)

The basic requirements of the Enclosure I of the PED must be fulfilled. The CE-sign at the valve includes the PED. A certificate of conformity of this directive will be available on request.

Note to Electromagnetic Compatibility Guideline (EMC):

The valves shall be provided with an electrical circuit which ensures the limits of the harmonised standards EN 61000-6-3 and EN 61000-6-1 are observed, and hence the requirements of the Electromagnetic Compatibility Guideline (2004/108/EC) satisfied.