

# 2/2-way valves ND 15 to 100



For neutral gaseous and liquid fluids  
 Solenoid actuated, with forced lifting  
 Piston seat valves  
 Flange connection ANSI B 16.5 – 150 lbs RF  
 Operating pressure 0 to 16 bar



06.09.95  
 Catalogue index  
**A 5**

85 400/84 400 series

## Description (standard valve)

Solenoid valve for air, water and oil

Flow direction: determined  
 Fluid temperature: max. +90 °C  
 Ambient temperature: max. +50 °C  
 Sum of fluid and ambient temperature: max. +130 °C  
 Mounting position: optional, solenoid preferably mounted vertical on top, ND 65 and larger, solenoid on top in vertical position imperative

Material Body: Grey cast iron  
 Seat seal: NBR  
 Internal parts: 1.4104, 1.4301, Brass, Gun metal

For contaminated fluids insertion of a strainer is recommended (see accessories).



## Features

- Flat piston valve
- Valve operates without pressure differential ( $\Delta p$ )
- High flow rate
- Damped operation

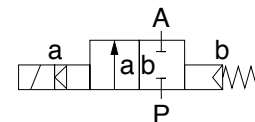

Switching function:  
 Normally closed

## Characteristic data

ND	Operating pressure with gaseous and liquid fluids up to 40 mm <sup>2</sup> /s (cSt) [bar]		K <sub>v</sub> -value <sup>1)</sup> (Base m <sup>3</sup> /h)	Weight [kg]	Section no	Dimension table no	Cat no			
	min.	max.					Valve XX XXX	Solenoid DC XX.XXXX	Valve XX XXX	Solenoid AC XX.XXXX
15	0	16	5.5	5.0	01	01	85 402	00.8401	85 402	00.8404
20	0	16	10.0	5.3	01	02	85 403	00.8401	85 403	00.8404
25	0	16	12.5	5.7	01	03	85 404	00.8401	85 404	00.8404
32	0	16	27.0	10.5	01	04	85 405	00.8401	85 405	00.8404
40	0	16	31.0	11.3	01	05	85 406	00.8401	85 406	00.8404
50	0	16	43.0	13.6	01	06	85 407	00.8401	85 407	00.8404
65	0	16	67.0	34.0	02	07	84 408	00.9501	84 408	00.9504
80	0	16	94.0	42.0	02	08	84 409	00.9501	84 409	00.9504
100	0	16	144.0	61.0	02	09	84 410	00.9501	84 410	00.9504

On request ND 150

State voltage [V] and frequency [Hz]

<sup>1)</sup> C<sub>v</sub>-value (US) ≈ k<sub>v</sub>-value x 1.2

**Remark:** Blade Dimensions of the flanges do not correspond to ANSI standard. Produced from flanges acc. to DIN 2533.

## IMI Norgren Buschjost GmbH + Co. KG

PO Box 10 02 52-53  
 D-32502 Bad Oeynhausen

Tel +49 (0) 57 31 79 10  
 Fax +49 (0) 57 31 79 11 79

<http://www.buschjost.com>  
 e-mail:mail@buschjost.de

## Solenoids

Standard-voltages	DC	AC 40 Hz to 60 Hz
	24 V – 205 V	24 V 110 V 230 V

Design acc. to VDE 0580  
Voltage range  $\pm 10\%$   
100 % duty cycle  
Protection class acc. to EN 60529 IP 65 (previous DIN 40 050)

**Attention! Restricted temperature range for explosion proof solenoids**

For technical details see catalog-register "Solenoids"

## Further models

available at extra cost

- XX XXX **01.XXXX** Normally open, mounting position: solenoid vertical on top
- XX XXX **02.XXXX** Manual override
- XX XXX **03.XXXX** Seat seal FPM, fluid temperature max.  $+110\text{ }^{\circ}\text{C}^{2)}$
- XX XXX **06.XXXX** Seat seal PTFE, fluid temperature max.  $+110\text{ }^{\circ}\text{C}^{2)}$
- XX XXX **14.XXXX** Seat seal EPDM, fluid temperature max.  $+110\text{ }^{\circ}\text{C}$
- XX XXX **17.XXXX** Normally open, seat seal FPM, fluid temperature max.  $+110\text{ }^{\circ}\text{C}^{2)}$ , mounting position: solenoid vertical on top
- XX XXX **23.XXXX** Position indicator with two solenoid switches
- XX XXX **25.XXXX** Seat seal FPM, only up to ND 50, with larger bleed orifices in the piston, viscosity max.  $80\text{ mm}^2/\text{s}$  (cSt), fluid temperature max.  $+110\text{ }^{\circ}\text{C}^{2)}$
- XX XXX **34.XXXX** Enlarged closing force, advisable at low flow rate and low switching cycles;  $k_V$ -value reduced appr.  $-20\%$
- **On request** Further versions

## Power consumption <sup>1)</sup>

Solenoid	DC	AC Inrush and Holding
	8401 8404 9501 9504	40 W – 80 W –

Socket acc. to DIN 43 650 at solenoid 8401/8404, AC solenoid with rectifier.

<sup>1)</sup> **According to VDE 0580 at coil temperature  $+20\text{ }^{\circ}\text{C}$ . In operating the solenoid coil decrease the power consumption appr.  $30\%$ .**

- XX XXX XX.**8402** Solenoid for higher fluid temperature max.  $+200\text{ }^{\circ}\text{C}$ , mounting position: vertical with solenoid underneath, for D.C. only
- XX XXX XX.**8406** Same as 8402, for A.C. only
- XX XXX XX.**8436** Solenoid in protection class EEx me II T4
- XX XXX XX.**8441** Solenoid in protection class EEx me II T3
- XX XXX XX.**8900** Solenoid in protection class EEx de IIC T4 and T5, Size  $\leq$  ND 50
- XX XXX XX.**8920** Solenoid in protection class EEx d IIC T4 and T5, up to ND 50
- XX XXX XX.**9502** Solenoid for higher fluid temperature max.  $+150\text{ }^{\circ}\text{C}$ . Size  $> =$  ND 65
- XX XXX XX.**9540** Solenoid in protection class EEx me II T3/T4, Size  $> =$  ND 65 and larger
- **On request** Further versions

<sup>2)</sup> max. temp.  $+200\text{ }^{\circ}\text{C}$  see solenoid for higher temperature (please observe DIN 2401)

## Sections

### 01

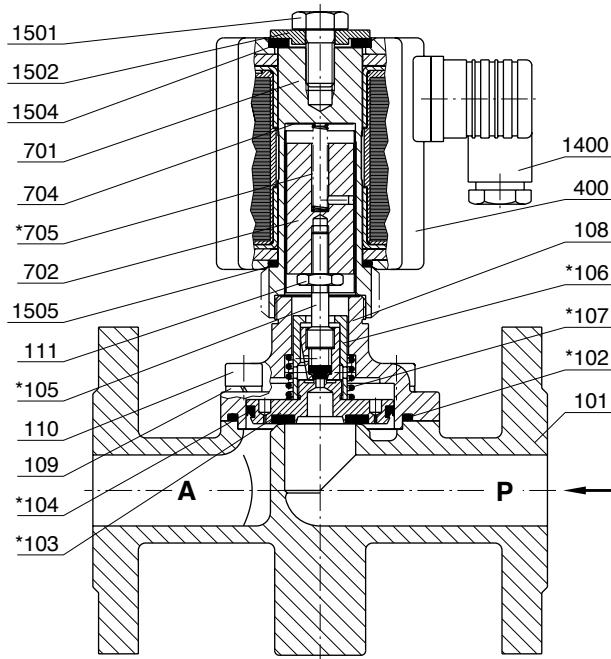

- |      |                                |      |                      |
|------|--------------------------------|------|----------------------|
| 101  | Valve body                     | 111  | Hexagon nut          |
| *102 | O - ring                       | 400  | Solenoid             |
| *103 | Valve plate                    | 701  | Core tube            |
| *104 | Grooved ring                   | 702  | Core                 |
| *105 | Valve spindle                  | 704  | Anti magnetic spacer |
| *106 | Screw piece                    | *705 | Pressure spring      |
| *107 | Pressure spring, not for ND 15 | 1400 | Socket               |
| 108  | Body cover                     | 1501 | Hexagon screw        |
| 109  | Spring washer                  | 1502 | Round plate          |
| 110  | Cheese head cap screw          | 1504 | Gasket               |
|      |                                | 1505 | O-ring               |

### 02

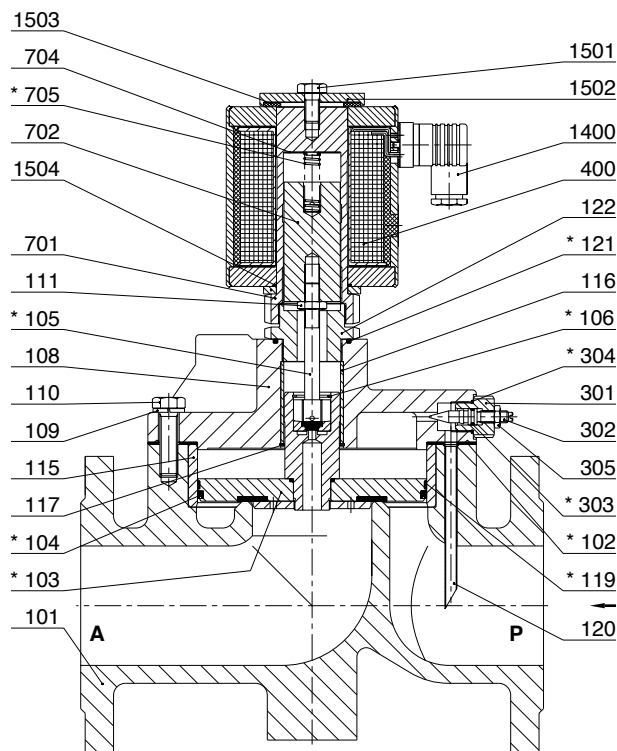

- |      |               |      |                      |
|------|---------------|------|----------------------|
| 101  | Valve body    | 301  | Screw piece          |
| *102 | Gasket        | 302  | Valve spindle        |
| *103 | Valve piston  | *303 | O-ring               |
| *104 | Grooved ring  | *304 | O-ring               |
| *105 | Valve spindle | 305  | Hexagon nut          |
| *106 | Locking ring  | 400  | Solenoid             |
| 108  | Body cover    | 701  | Core tube            |
| 109  | Spring washer | 702  | Core                 |
| 110  | Hexagon screw | 704  | Anti magnetic spacer |
| 111  | Hexagon nut   | *705 | Pressure spring      |
| 115  | Bushing       | 1400 | Socket               |
| 116  | Bushing       | 1501 | Hexagon screw        |
| 117  | Circilp       | 1502 | Round plate          |
| *119 | Guide foil    | 1503 | Gasket               |
| 120  | Tube          | 1504 | O-ring               |
| *121 | O-ring        | 1505 | Round plate          |
| 122  | Screw piece   |      |                      |

To avoid high shock pressure, you can control the closing time with the adjusting stem pos. 302. Turning clockwise increases restriction and slows down closing speed. A totally closed restriction would result in a malfunction.

\* These individual parts form a complete wearing unit.  
When ordering spare parts please state Cat no and series no.

# Dimensions

01

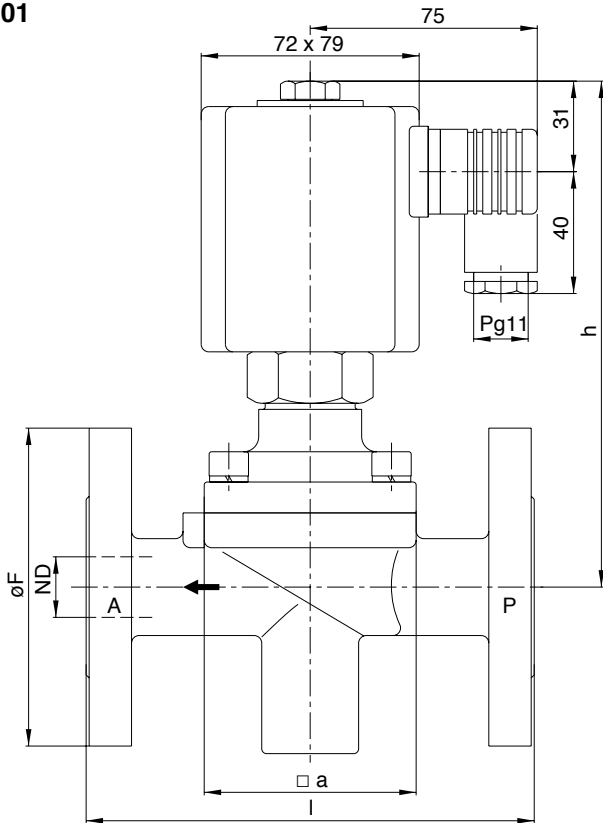

Flange connection ANSI B 165 – 150 lbs RF  
Contact face „Stock Finish“

Dimension table no	a	h	l
01	70	170	130
02	70	172	150
03	70	172	160
04	96	187	180
05	96	191	200
06	112	200	230

Dimension table no	ND	Ø F	
01	15	88,9	
02	20	98,4	
03	25	107,9	
04	32	117,5	
05	40	127,0	
06	50	152,4	

02

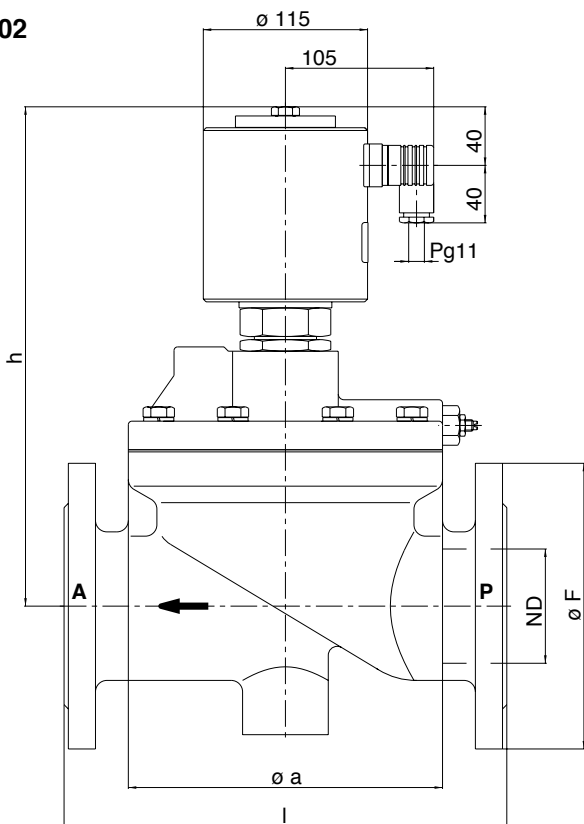

Flange connection ANSI B 16.5 – 150 lbs RF  
Contact face „Stock Finish“

Dimension table no	Ø a	h	l
07	195	330	290
08	220	350	310
09	260	378	350

Dimension table no	ND	Ø F	
07	65	177,8	
08	80	190,5	
09	100	220,0	

Solenoid may be rotated 360°

Socket turnable 4 x 90°