

2/2-way ND 15 to 50

with Inspection certificate DIN 50 049 (EN 10204) -3.1.B



for slightly aggressive gaseous and liquid fluids
Solenoid actuated, with forced lifting
Piston seat valves
Flange connection PN 25 / PN 40
Operating pressure 0 to 25 bar

Stainless Steel

Publication 7502702.06.02.96
Catalogue index
A 12
85 640 / 84 640 series

Description (standard valve)

Stainless steel solenoid valve for slightly aggressive gaseous and liquid fluids

Flow direction: determined
Fluid temperature: - 20 to max +90 °C
Ambient temperature: max +50 °C
Sum of fluid- and ambient temperature: max +130 °C
Mounting position: optional, solenoid preferably vertical on top, ND 65 and larger, only vertical on top

Material Body: and cover 316 SS
Seat seal: NBR special
Internal parts: Stainless steel, 304, 301 SS up to ND 50
430F from ND 65

For contaminated fluids insertion of a strainer is recommended (see accessories).



Features

- Valve operates without minimum pressure differential (Δp)
- High flow rate
- Damped operating
- Suitable for vacuum

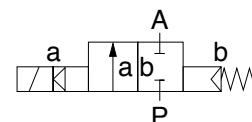

Switching function:
Normally closed

Characteristic data

ND	Operating pressure with gaseous and liquid fluids up to 40 mm ² /s(cSt) [bar]		kv-value (base m ³ /h)	Weight [kg]	Sectional diagram no	Dimension table no	Cat no			
	min	max					Valve	Solenoid DC	Valve	Solenoid AC
[mm]							XX XXX XX. XXXX		XX XXX XX. XXXX	
15	0	25	5.5	5.5	01	01	85 642 00. 8401		85 642 00. 8404	
20	0	25	10.0	5.8	01	02	85 643 00. 8401		85 643 00. 8404	
25	0	25	12.5	6.2	01	03	85 644 00. 8401		85 644 00. 8404	
32	0	25	27.0	11.0	01	04	85 645 00. 8401		85 645 00. 8404	
40	0	25	31.0	11.8	01	05	85 646 00. 8401		85 646 00. 8404	
50	0	25	43.0	14.0	01	06	85 647 00. 8401		85 647 00. 8404	
65 ¹⁾	0	25	67.0	36.5	02	07	84 648 00. 9501		84 648 00. 9504	
80 ¹⁾	0	25	94.0	46.5	02	08	84 649 00. 9501		84 649 00. 9504	
100 ¹⁾	0	25	144.0	70.0	02	09	84 650 00. 9501		84 650 00. 9504	

¹⁾ Pressure range PN 25

State voltage [V] and frequency [Hz] angeben

IMI Norgren Buschjost GmbH + Co. KG

PO Box 10 02 52-53
D-32502 Bad Oeynhausen

Tel +49 (0) 57 31 79 10
Fax +49 (0) 57 31 79 11 79

<http://www.buschjost.com>
e-mail: mail@buschjost.de

Inspection certificate DIN 50 049 (EN 10240) -3.1.B

Three different certificates are available

- **12 374 65.0000** Material quality proof for body, cover and body screws acc. to DIN 50 049-3.1.B, material quality proof for fluid contacted parts. acc. to DIN 50049-2.2, function and leak test acc. to DIN 50049.3.1.B

- **12 392 49.0000** Material quality proof for body, cover and body screws acc. to DIN 50049-3.1.B

Solenoids

Standard voltages	DC	AC 40 Hz to 60 Hz
	24 V	24 V
	–	110 V
	205 V	230 V

Design acc. to VDE 0580

Voltage range $\pm 10\%$

100 % duty cycle

Protection class acc. to EN 60529 IP 65

(previous DIN 40050)

Attention! Restricted temperature range for explosion proof solenoids

For technical details see catalog-register "Solenoids"

Further models

available at extra cost

- XX XXX **01.XXXX** Normally open, mounting position: solenoid vertical on top
- XX XXX **02.XXXX** Manual override
- XX XXX **03.XXXX** Seat seal FPM, fluid temperature max. $+110\text{ }^{\circ}\text{C}$
- XX XXX **06.XXXX** Seat seal PTFE, fluid temperature max $+110\text{ }^{\circ}\text{C}$, working pressure max 16 bar, **pressure rate PN 16/** leakage rate 2
- XX XXX **14.XXXX** Seat seal EPDM, fluid temperature max. $+110\text{ }^{\circ}\text{C}$
- XX XXX **22.XXXX** Operating pressure: max. 40 bar up to ND 50
- XX XXX **34.XXXX** Enlarged closing force, advisable at low flow rate and low switching cycles
- XX XXX **60.XXXX** Gasket between body and cover material FPM, $> \text{ND } 50$
- **On request** Further versions

Power consumption ¹⁾

Solenoid	DC	AC Inrush and Holding
8401	40 W	–
8404	–	45 VA
9501	80 W	–
9504	–	89 VA

Socket acc. to DIN 43650;

AC solenoid with rectifier.

¹⁾ According to VDE 0580 at coil temperature $+20\text{ }^{\circ}\text{C}$. In operation the power consumption of the solenoid decreases appr. 30%.

- XX XXX XX.**8436** Solenoid in protection class EEx me II T4
- XX XXX XX.**8441** Solenoid in protection class EEx me II T3
- XX XXX XX.**8900** Solenoid in protection class EEx de IIC T4 and T5, up to ND 50 only ²⁾
- XX XXX XX.**8920** Solenoid in protection class EEx d IIC T4 and T5, up to ND 50 only ²⁾
- XX XXX XX.**9540** Solenoid in protection class EEx me T3/T4, from ND 65
- **On request** Overexcitation; solenoid in protection class EEx d I, EEx de I, special connections

²⁾ Belongs to solenoid series 84XX

Sections

01

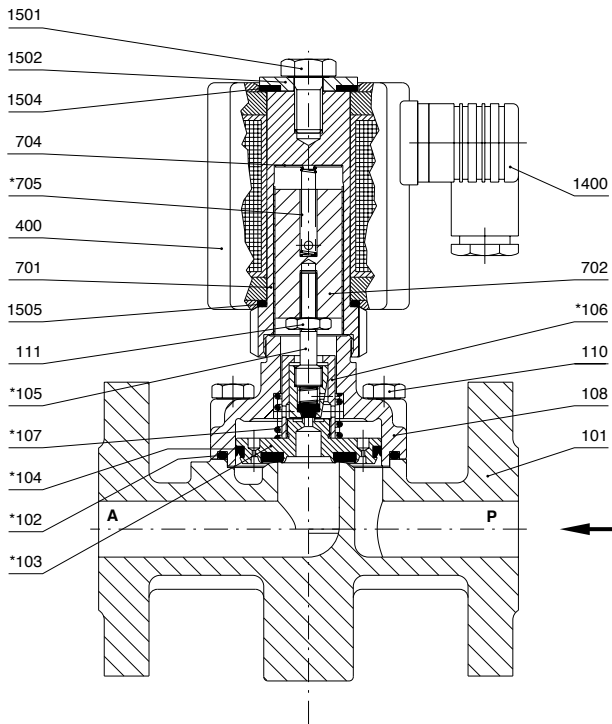

- | | |
|--|--------------------------|
| 101 Valve body | 400 Solenoid |
| *102 O-ring | 701 Core tube |
| *103 Valve plate | 702 Core |
| *104 Grooved ring | 704 Anti magnetic spacer |
| *105 Valve spindle | *705 Pressure spring |
| *106 Screw piece | 1400 Socket |
| *107 Pressure spring, not for ND 15 | 1501 Hexagon screw |
| 108 Body cover | 1502 Round plate |
| 109 Spring washer (only for ND 15; not sketched) | 1504 Gasket |
| 110 Hexagon screw | 1505 O-ring |
| 111 Hexagon nut | |

02

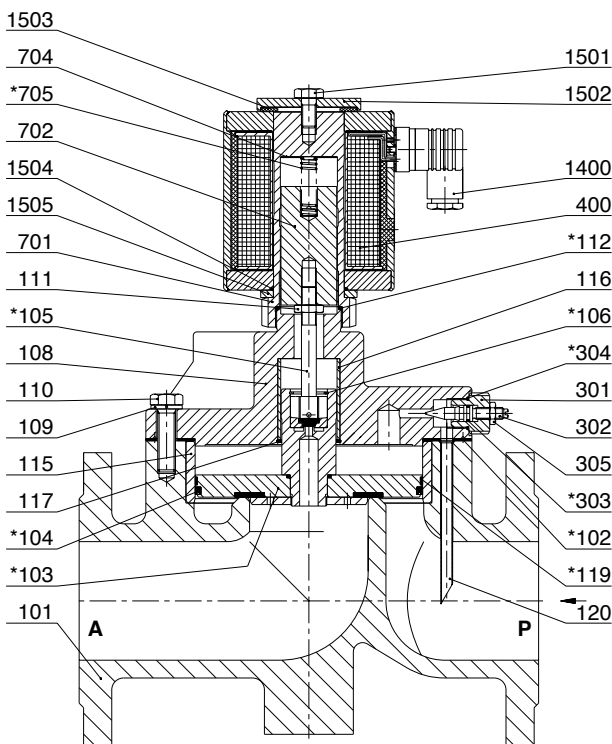

- | | |
|--------------------|----------------------|
| 101 Valve body | 301 Screw piece |
| *102 Gasket | 302 Valve spindle |
| *103 Valve piston | *303 O-ring |
| *104 Grooved ring | *304 O-ring |
| *105 Valve spindle | 305 Hexagon nut |
| *106 Locking ring | 400 Solenoid |
| 108 Body cover | 701 Core tube |
| 109 Spring washer | 702 Core |
| 110 Hexagon screw | 704 Round plate |
| 111 Hexagon nut | *705 Pressure spring |
| *112 Seal ring | 1400 Socket |
| 115 Bushing | 1501 Hexagon screw |
| 116 Bushing | 1502 Round plate |
| 117 Snap ring | 1503 Gasket |
| *119 Guide foil | 1504 O-ring |
| 120 Tube | 1505 Round plate |

To avoid high shock pressure, you can control the closing time with the adjusting stem pos. 302. Turning clockwise increases restriction and slows down closing speed. A totally closed restriction would result in a malfunction.

*These individual parts form a complete wearing unit. When ordering spare parts please state Cat. No. and series No.

Dimensions

01

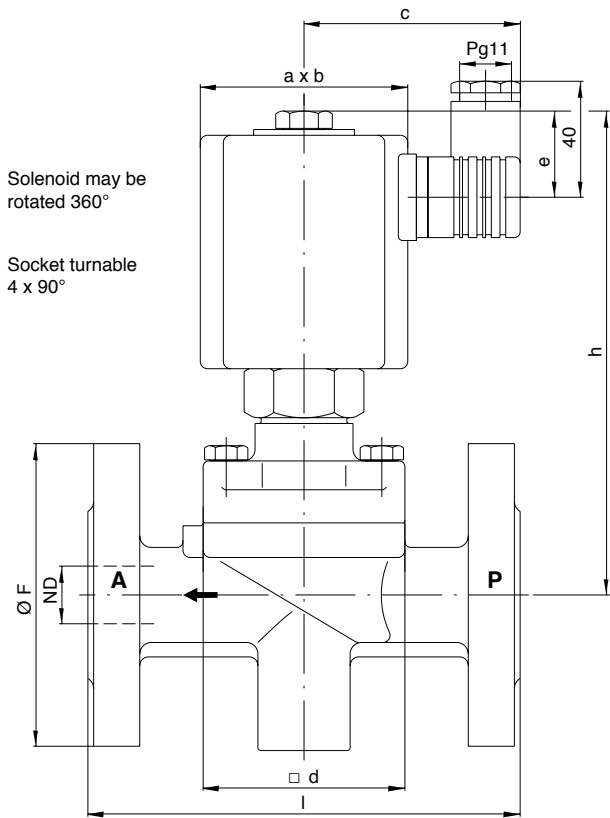

Flange connection PN 40 acc. to DIN 2545
Contact face DIN 2526 type C

Dimension table no	□ a	h	l
01	70	170	130
02	70	172	150
03	70	172	160
04	96	187	180
05	96	191	200
06	112	200	230

Dimension table no	ND	Ø F	
01	15	95	
02	20	105	
03	25	115	
04	32	140	
05	40	150	
06	50	165	

02

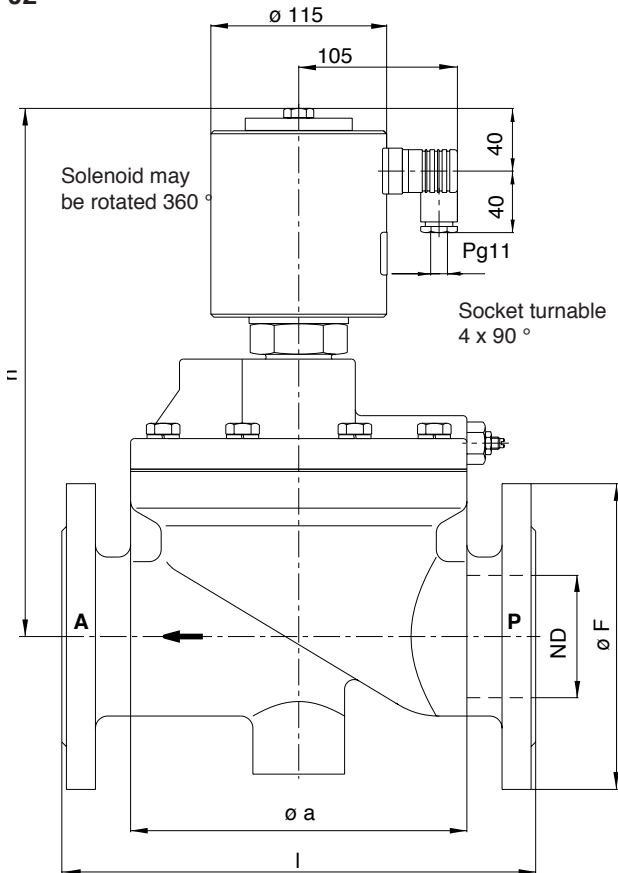

Flange connection PN 25 acc. to DIN 2544/2545
Contact face DIN 2526 type C

Dimension table no	Ø a	h	l
07	195	327	290
08	220	347	310
09	265	376	350

Dimension table no	ND	Ø F	
07	65	185	
08	80	200	
09	100	235	