

2/2-way valves ND 10 to 25



for slightly aggressive gaseous and liquid fluids
 Solenoid actuated, with forced lifting
 Piston seat valves, made of stainless steel
 Internal threads G 3/8 to G 1
 Operating pressure 0 to 25 bar

Stainless Steel

Publication 7500969.06.12.04
 Catalogue index
 A 12
 85 040 series

Description (standard valve)

Solenoid valve for slightly aggressive gaseous and liquid fluids

Flow direction: determined
 Fluid temperature: -20 °C to +90 °C
 Ambient temperature: max. +50 °C
 Sum of fluid- and ambient temperature: max. +130 °C
 Mounting position: optional, solenoid preferably vertical on top
 Material Body: Stainless steel, B.S. 316 C17
 Seat seal: NBR (cold flexibel)
 Internal parts: Stainless steel, Sandvik 1802 (ferrous stainless steel)



For contaminated fluids insertion of a strainer is recommended (see accessories).

Features

- Flat piston valve
- Valve operates without pressure differential (Δp)
- High flow rate
- Damped operation
- Suitable for vacuum

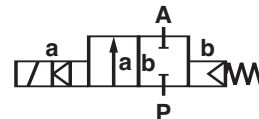

Switching function:
 Normally closed

Characteristic data

ND [mm]	Conne- ction (Thread acc. to DIN ISO 228/1)	Operating pressure with gaseous and liquid fluids 40 mm ² /s(cSt) [bar]		kv-value ¹⁾ (Base m ³ /h)	Weight [kg]	Section no	Dimen- sion table no	Cat no			
		min.	max.					Valve	Solenoid DC	Valve	Solenoid AC
10	G 3/8	0	25	3.4	1.50	01	00	XXXXXXXX.XXXX	XXXXXXXX.XXXX	8504100.8301	8504100.8304
12	G 1/2	0	25	3.8	1.45	01	01	XXXXXXXX.XXXX	XXXXXXXX.XXXX	8504200.8301	8504200.8304
20	G 3/4	0	25	11.0	3.65	02	02	XXXXXXXX.XXXX	XXXXXXXX.XXXX	8504300.8401	8504300.8404
25	G 1	0	25	13.0	3.50	02	03	XXXXXXXX.XXXX	XXXXXXXX.XXXX	8504400.8401	8504400.8404

¹⁾ Cv-value (US) \approx kv-value x 1.2

State voltage [V] and frequency [Hz]

IMI Norgren Buschjost GmbH + Co. KG

Postfach 10 02 52-53
 D-32502 Bad Oeynhausen

Telefon (0 57 31) 7 91-0
 Telefax (0 57 31) 79 11 79

<http://www.buschjost.de>
 e-mail: mail@buschjost.de

Solenoids

Standard voltages	D.C.	A.C. 40 Hz to 60 Hz
	24 V – 205 V	24 V 110 V 230 V

Design acc. to VDE 0580
Voltage range $\pm 10\%$
100 % duty cycle
Protection class acc. to DIN EN 175301-803
(10/00) IP65

Attention! Restricted temperature range for explosion proof solenoids.

For technical details see catalog register "Solenoids"

Further models

available at extra cost

- XXXXX01.XXXX Normally open, mounting position: solenoid vertical on top ³⁾
- XXXXX03.XXXX Seat seal FKM, fluid temperature $-10\text{ }^{\circ}\text{C}$ to $+110\text{ }^{\circ}\text{C}$ ²⁾
- XXXXX06.XXXX Seat seal PTFE, fluid temperature up to max. $+110\text{ }^{\circ}\text{C}$ ²⁾, operating pressure max. 16 bar
- XXXXX14.XXXX Seat seal EPDM, fluid temperature up to max. $+110\text{ }^{\circ}\text{C}$
- XXXXX22.XXXX Operating pressure max. 40 bar ³⁾
- XXXXX23.XXXX Position indicator with two solenoid switches ³⁾
- XXXXX34.XXXX Enlarged closing force, advisable at low flow rate and low switching cycles
- XXXXX40.XXXX Electrical position EEx
- XXXXX41.XXXX Electrical position indicator with two magnetic field sensors

Power consumption ¹⁾

Solenoid	D.C.	A.C. Inrush and Holding
8301	22 W	–
8304	–	25 VA
8401	40 W	–
8404	–	45 VA

Socket acc. to DIN 43650,
A.C. solenoid with rectifier

¹⁾ **According to VDE 0580 at coil temperature $+20\text{ }^{\circ}\text{C}$. In operating the solenoid decrease the power consumption appr. 30 %.**

- XXXXXX.8402 Solenoid for higher temperature up to max. $+200\text{ }^{\circ}\text{C}$ fluid temperature, mounting position: vertical, with solenoid underneath, for D.C. only
- XXXXXX.8406 Same as 8402, for A.C. only
- XXXXXX.8341 Solenoid in protection class EEx me II T3
- XXXXXX.8436 Solenoid in protection class EEx me II T4
- XXXXXX.8441 Solenoid in protection class EEx me II T3
- XXXXXX.8900 Solenoid in protection class EEx de IIC T4 and T5,
- XXXXXX.8920 Solenoid in protection class EEx d IIC T4 and T5,
- **On request** Solenoid with overexcitation, special connections

²⁾ fluid temperature up to max. $+200\text{ }^{\circ}\text{C}$ see solenoid for higher temperatures

³⁾ G 3/8 and G 1/2 with solenoid 8401/8404

Sectional drawings

01

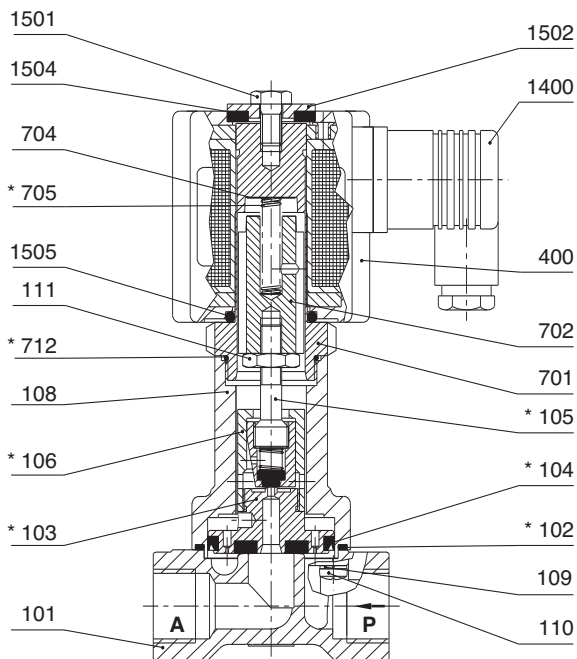

- | | |
|---------------------------|----------------------|
| 101 Valve body | 701 Core tube |
| *102 Gasket | 702 Core |
| *103 Valve plate | 704 Round plate |
| *104 Grooved ring | *705 Pressure spring |
| *105 Valve spindle | *712 O-ring |
| *106 Screw piece | 1400 Socket |
| 108 Body cover | 1501 Hexagon screw |
| 109 Spring washer | 1502 Round plate |
| 110 Cheese head cap screw | 1504 Gasket |
| 111 Hexagon nut | 1505 O-ring |
| 400 Solenoid | |

02

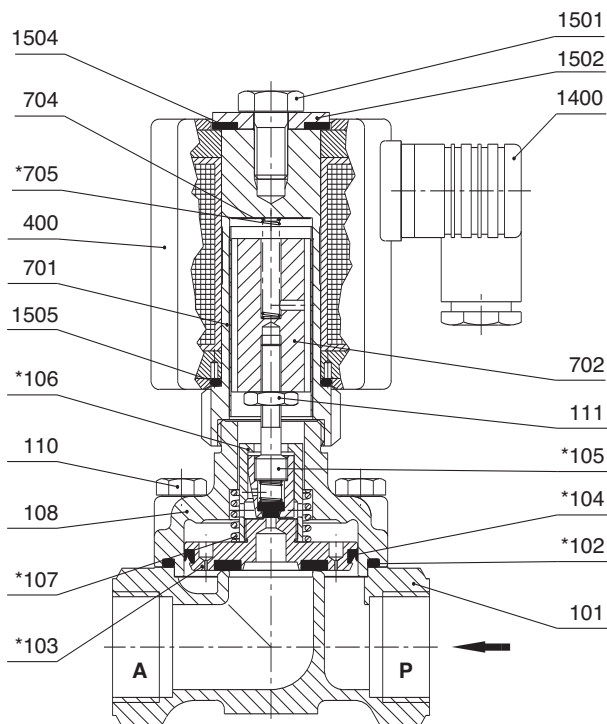

- | | |
|----------------------|----------------------|
| 101 Valve body | 701 Core tube |
| *102 Gasket | 702 Core |
| *103 Valve plate | 704 Round plate |
| *104 Grooved ring | *705 Pressure spring |
| *105 Valve spindle | 1400 Socket |
| *106 Screw piece | 1501 Hexagon screw |
| *107 Pressure spring | 1502 Round plate |
| 108 Body cover | 1504 Gasket |
| 110 Hexagon screw | 1505 O-ring |
| 111 Hexagon nut | |
| 400 Solenoid | |

* These individual parts form a complete wearing unit.

When ordering spare parts please state Cat no and series no.

Dimensions

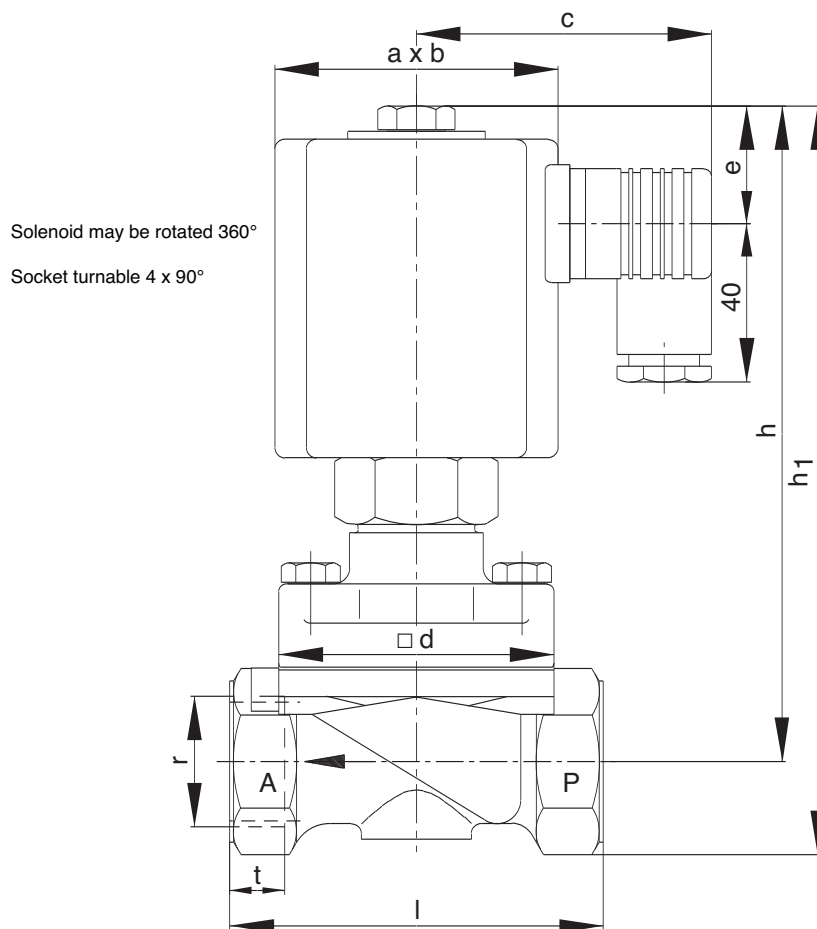

Dimension table no	a x b	c	□ d	e	h	h ₁	l	r	t
00	52 x 65	65	45	26	150	165	67	G 3/8	12.0
01	52 x 65	65	45	26	150	165	67	G 1/2	12.0
02	72 x 92	75	70	31	172	196	95	G 3/4	12.5
03	72 x 92	75	70	31	172	196	95	G 1	14.0

Note to Pressure Equipment Directive (PED):

The valves of this series, including the connection-size DN 25 (G 1), are according to Art. 3 § 3 of the Pressure Equipment Directive (PED) 97/23/EG. This means interpretation and production are in accordance to engineers practice wellknown in the member countries.

The CE-sign at the valve refers not to the PED. Thus the declaration of conformity is not longer applicable for this directive.

For valves > DN 25 (G 1) Art. 3 § (1) No.1.4 applies.

The basic requirements of the Enclosure I of the PED must be fulfilled. The CE-sign at the valve includes the PED. A certificate of conformity of this directive will be available on request.

Note to Electromagnetic Compatibility Guideline (EEC):

The valves shall be provided with an electrical circuit which e limits of the harmonised standards EN 50081-1 and EN 50082-1 observed, and hence the requirements of the Electromagnetic Compatibility Guideline (89/336/EEC) satisfied.