

2/2-way valves ND 15 to 100



for neutral steam and liquid fluids
Solenoid actuated, with forced lifting
Piston seat valves
Flange connection PN 16
Operating pressure 0 to 16 bar



Publication 7500976.06.05.97
Catalogue index
A 5
85 120/84 120 series

Description (standard valve)

Solenoid valve for hot water and steam

Flow direction: determined
Fluid temperature: max. +200 °C
Ambient temperature: max. +60 °C
Sum of fluid- and ambient temperature: max. +260 °C
Mounting position: solenoid vertical to underneath ¹⁾
Material Body: Grey cast iron with gun metal seat
Seat seal: PTFE
Internal parts: 1.4104, 1.4301, gun metal



For contaminated fluids insertion of a strainer is recommended (see accessories).
Fluid temperature higher than +120 °C: pay attention to DIN 2401!

Features

- Flat piston valve
- Valve operates without pressure differential (Δp)
- High flow rate
- Damped operation

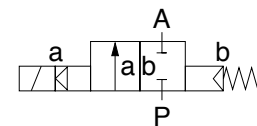

Switching function:
Normally closed

Characteristic data

ND	Operating pressure with gaseous and liquid fluids up to 80 mm ² /s (cSt) [bar]		k _v -value ⁴⁾ (Base m ³ /h)	Weight [kg]	Section no	Dimension table no	Cat no			
	min.	max.					Valve	Solenoid DC	Valve	Solenoid AC
[mm]							XX XXX XX. XXXX		XX XXX XX. XXXX	
15	0	16	5	3.5	01	01	85 122 00. 8302		85 122 00. 8306	
20	0	16	8	5.3	01	02	85 123 00. 8402		85 123 00. 8406	
25	0	16	10	5.7	01	03	85 124 00. 8402		85 124 00. 8406	
32	0	16	27	10.5	01	04	85 125 00. 8402		85 125 00. 8406	
40	0	16	30	11.3	01	05	85 126 00. 8402		85 126 00. 8406	
50	0	16	41	13.6	01	06	85 127 00. 8402		85 127 00. 8406	
65	0	16	67	48.0	02	07	85 128 00. 8602		³⁾	
65	0	16	67	34.0	03	08	84 128 00. 9502 ²⁾		84 128 00. 9506 ²⁾	
80	0	16	94	56.0	02	09	84 129 00. 8602		³⁾	
80	0	16	94	42.0	03	10	84 129 00. 9502 ²⁾		84 129 00. 9506 ²⁾	
100	0	16	144	75.0	02	11	84 130 00. 8602		³⁾	
100	0	16	144	61.0	03	12	84 130 00. 9502 ²⁾		84 130 00. 9506 ²⁾	

State voltage [V] and frequency [Hz]

¹⁾ Mounting position for ND 15 to 50 and fluid temperature up to max. +150 °C: solenoid vertical on top

²⁾ Fluid temperature up to max. +150 °C, mounting position: solenoid only on top

³⁾ For A.C. voltage: D.C. solenoids can be used with a separate rectifier in the switchboard

⁴⁾ C_v-value (US) ≈ k_v-value x 1.2

IMI Norgren Buschjost GmbH + Co. KG

PO Box 10 02 52-53
D-32502 Bad Oeynhausen

Tel +49 (0) 57 31 79 10
Fax +49 (0) 57 31 79 11 79

<http://www.buschjost.com>
e-mail: mail@buschjost.de

Solenoids

Standard voltages	DC	AC 40 Hz to 60 Hz
	24 V – 205 V	24 V 110 V 230 V

Design acc. to VDE 0580

Voltage range $\pm 10\%$

100 % duty cycle

Protection class acc. to EN 60529 IP 65

(previous DIN 40050)

For technical details see catalog register "Solenoids".

Further models

available at extra cost

- XX XXX **01.XXXX** Normally open, solenoid vertical on top ²⁾, for ND 32 to ND 50, fluid temperature max. +150 °C ²⁾
- XX XXX **02.XXXX** Manual override
- XX XXX **14.XXXX** Seat seal EPDM, max. fluid temperature +130 °C

²⁾ Solenoid 9502 for higher temperature up to max. +200 °C and hanging mounting position

Sections

01

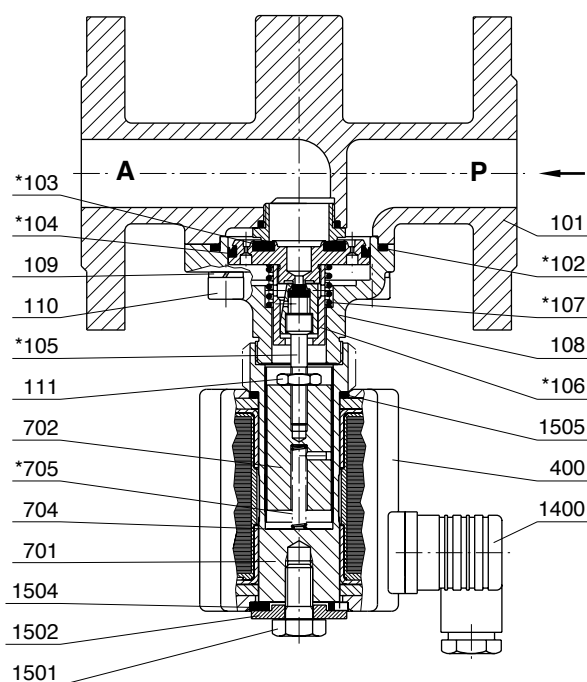

Power consumption ¹⁾

Solenoid	DC	AC Inrush and Holding
8302	14 W	–
8306	–	16 VA
8402	29 W	–
8406	–	33 VA
9502	55 W	–
9506	–	61 VA
8602	100 W	–

Socket acc. to DIN 43650 at solenoid 8402/8406;

9502/9506 AC solenoid with rectifier.

Terminal in solenoid housing 8602

¹⁾ According to VDE 0580 at coil temperature +20 °C. In operating the solenoid coil decrease the power consumption appr. 30 %.

- XX XXX **23.XXXX** Position indicator with two solenoid switches
- XX XXX **34.XXXX** Enlarged closing force, advisable at low flow rate and low switching cycles (k_V -value reduced appr. -20%)
- **On request** Further versions

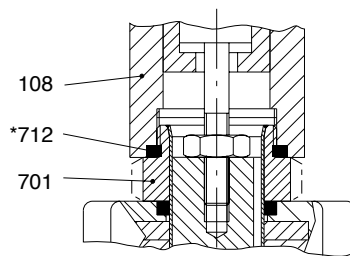

- | | |
|---------------------------|------------------------------|
| 101 Valve body | 701 Core tube |
| *102 O-ring | 702 Core |
| *103 Valve plate | 704 Round plate |
| *104 Grooved ring | *705 Pressure spring |
| *105 Valve spindle | *712 Gasket – for ND 15 only |
| *106 Screw piece | 1400 Socket |
| *107 Pressure spring | 1501 Hexagon screw |
| 108 Body cover | 1502 Round plate |
| 109 Spring washer | 1504 Gasket |
| 110 Cheese head cap screw | 1505 O-ring |
| 111 Hexagon nut | |
| 400 Solenoid | |

02

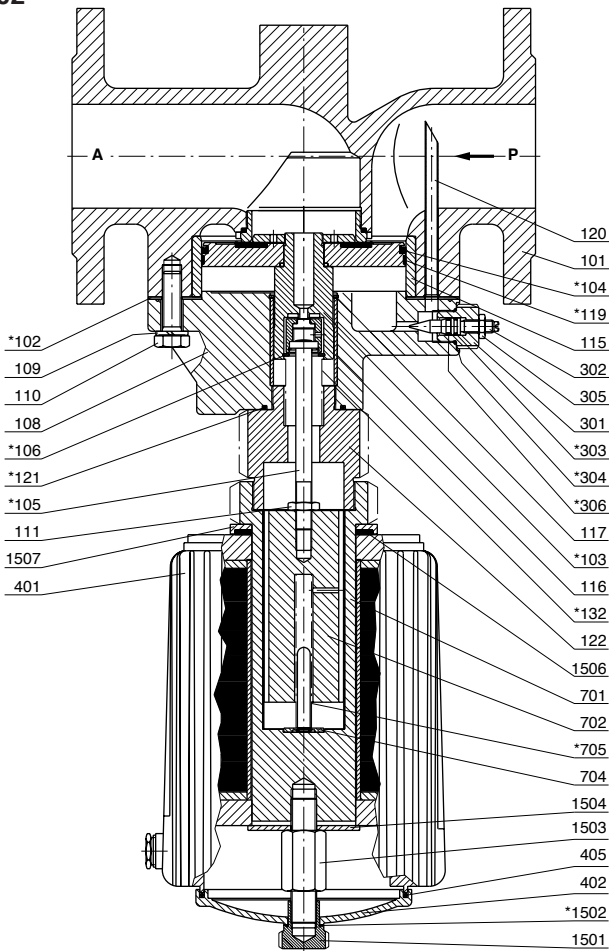

- | | |
|----------------------|----------------------|
| 101 Valve Body | 302 Valve spindle |
| *102 Gasket | *303 O-ring |
| *103 Valve piston | *304 O-ring |
| *104 Grooved ring | 305 Hexagon nut |
| *105 Valve spindle | *306 Grooved ring |
| *106 Locking ring | 401 Solenoid |
| 108 Body cover | 402 Solenoid cover |
| 109 Spring washer | 405 O-ring |
| 110 Hexagon screw | 701 Core tube |
| 111 Hexagon nut | 702 Core |
| 115 Bushing | 704 Guide pin |
| 116 Bushing | *705 Pressure spring |
| 117 Circlip | 1501 Screw piece |
| *119 Guide foil | 1502 O-ring |
| 120 Tube | 1503 Screw piece |
| *121 Seal ring | 1504 Round plate |
| 122 Screw piece | 1506 Gasket |
| *132 Pressure spring | 1507 Round plate |
| 301 Screw piece | |

03

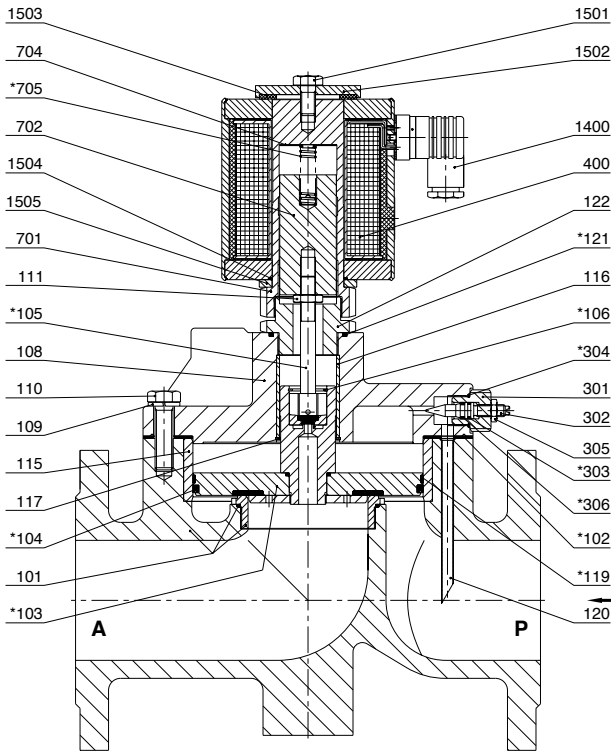

- | | |
|--------------------|----------------------|
| 101 Valve body | 302 Valve spindle |
| *102 Gasket | *303 O-ring |
| *103 Valve piston | *304 O-ring |
| *104 Grooved ring | 305 Hexagon nut |
| *105 Valve spindle | 306 Grooved ring |
| *106 Locking ring | 400 Solenoid |
| 108 Body cover | 701 Core tube |
| 109 Spring washer | 702 Core |
| 110 Hexagon screw | 704 Round plate |
| 111 Hexagon nut | *705 Pressure spring |
| 115 Bushing | 1400 Socket |
| 116 Bushing | 1501 Hexagon screw |
| 117 Circlip | 1502 Round plate |
| *119 Guide foil | 1503 Gasket |
| 120 Tube | 1504 O-ring |
| *121 Seal ring | 1505 Round plate |
| 122 Screw piece | |
| 301 Screw piece | |

To avoid high shock pressure, you can control the closing time with the adjusting stem pos. 302. Turning clockwise pos. 302 increases restriction and slows down the speed. A totally closed restriction would result in a malfunction.

* These individual parts form a complete wearing unit.

When ordering spare parts please state Cat. and series No.

Dimensions

01

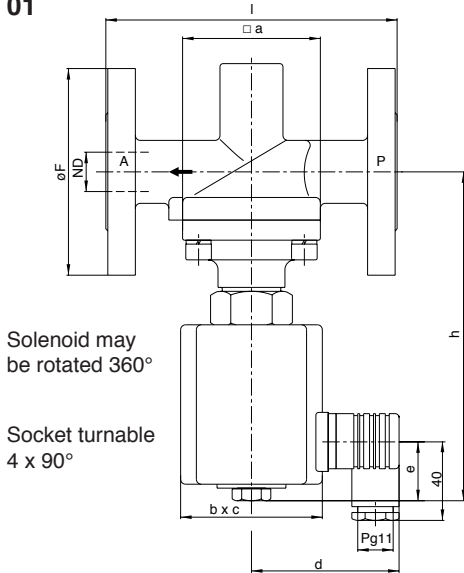

Flange connection PN 16 acc. to DIN 2533
Contact face DIN 2526 type C

Dimension table No.	a	b x c	d	e
01	70	52 x 65	65	26
02	70	72 x 92	75	31
03	70	72 x 92	75	31
04	96	72 x 92	75	31
05	96	72 x 92	75	31
06	112	72 x 92	75	31

Dimension table No.	h	l	ND	Ø F
01	145	130	15	95
02	172	150	20	105
03	172	160	25	115
04	187	180	32	140
05	191	200	40	150
06	200	230	50	165

Mounting position up to fluid temperature max. +150 °C: preferably solenoid vertical on top

02

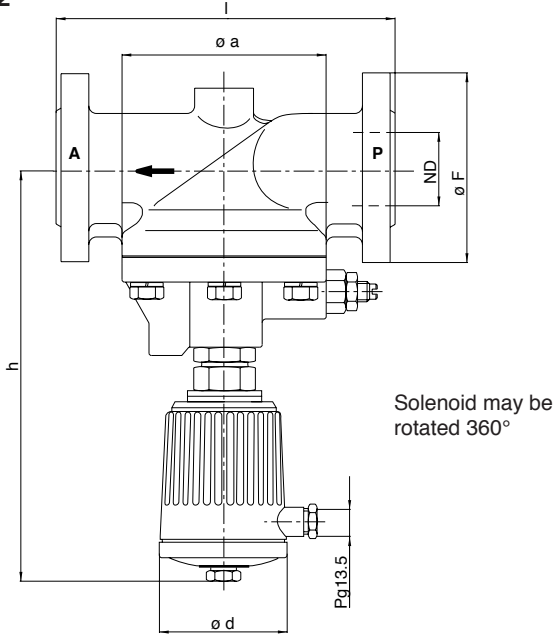

Flange connection PN 16 acc. to DIN 2533
Contact face DIN 2526 type C

Dimension table No.	Ø a	Ø d	h
07	195	180	485
08	220	180	505
09	260	180	535

Dimension table No.	l	ND	Ø F
07	290	65	185
08	310	80	200
09	350	100	220

Mounting position up to fluid temperature max. +200 °C: solenoid vertical to top.

03

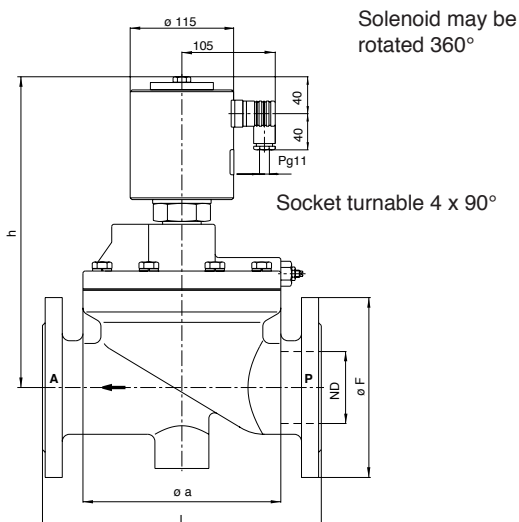

Flange connection PN 16 acc. to DIN 2533
Contact face DIN 2526 type C

Dimension table No.	Ø a	h	l
08	195	330	290
10	220	350	310
12	260	378	350

Dimension table No.	ND	Ø F
08	65	185
10	80	200
12	100	220

Mounting position up to fluid temperature max. +150 °C: solenoid only vertical to top.