

2/2-way valves ND 15 to 100



for slightly aggressive gaseous and liquid fluids
 Solenoid actuated, with forced lifting
 Piston seat valves
 Flange connection PN 16
 Operating pressure 0 to 16 bar

Stainless Steel

Publication 7502709.06.12.94
 Catalogue index
A 12
 85 140 / 84 140 series

Description (standard valve)

Stainless steel solenoid valve for slightly aggressive gaseous and liquid fluids

Flow direction: determined
Fluid temperature: -20 °C to +110 °C up to ND 50
 -10 °C to +110 °C from ND 65
Ambient temperature: max. +50 °C
Sum of fluid- and ambient temperature: max. +130 °C
Mounting position: optional, solenoid preferably vertical on top, ND 65 and larger, only vertical on top
Material Body: Stainless Steel (1.4581) B.S. 318 C17
Seat seal: PTFE
Internal parts: 1.4571, 1.4301, 1.4310; Sandvik 1802 up to ND 50; 1.4104 and 1.4105 from ND 65



For contaminated fluids insertion of a strainer is recommended (see accessories).

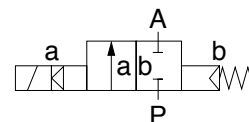

Features

- Valve operates without pressure differential (Δp)
- High flow rate
- Damped operating

Switching function:
 Normally closed

Characteristic data

ND [mm]	Operating pressure with gaseous and liquid fluids up to 40 mm ² /s (cSt) [bar]		kv-value ¹⁾ (Base m ³ /h)	Weight [kg]	Section no	Dimension table no	Cat no			
	min.	max.					Valve XX XXX XX	Solenoid DC XXXX	Valve XX XXX XX	Solenoid AC XXXX
15	0	16	5.5	5.5	01	01	85 142 00. 8301	85 142 00. 8301	85 142 00. 8304	85 142 00. 8304
20	0	16	10.0	5.8	01	02	85 143 00. 8401	85 143 00. 8401	85 143 00. 8404	85 143 00. 8404
25	0	16	12.5	6.2	01	03	85 144 00. 8401	85 144 00. 8401	85 144 00. 8404	85 144 00. 8404
32	0	16	27.0	11.0	01	04	85 145 00. 8401	85 145 00. 8401	85 145 00. 8404	85 145 00. 8404
40	0	16	31.0	11.8	01	05	85 146 00. 8401	85 146 00. 8401	85 146 00. 8404	85 146 00. 8404
50	0	16	43.0	14.0	01	06	85 147 00. 8401	85 147 00. 8401	85 147 00. 8404	85 147 00. 8404
65	0	16	67.0	36.5	02	07	84 148 00. 9501	84 148 00. 9501	84 148 00. 9504	84 148 00. 9504
80	0	16	94.0	46.5	02	08	84 149 00. 9501	84 149 00. 9501	84 149 00. 9504	84 149 00. 9504
100	0	16	144.0	70.0	02	09	84 150 00. 9501	84 150 00. 9501	84 150 00. 9504	84 150 00. 9504

State voltage [V] and frequency [Hz]

¹⁾ C_v-value (US) ≈ kv-value x 1.2

IMI Norgren Buschjost GmbH + Co. KG

PO Box 10 02 52-53
 D-32502 Bad Oeynhausen

Tel +49 (0) 57 31 79 10
 Fax +49 (0) 57 31 79 11 79

<http://www.buschjost.com>
 e-mail: mail@buschjost.de

Solenoids

Standard voltages	DC	AC 40 Hz to 60 Hz
	24 V – 205 V	24 V 110 V 230 V

Design acc. to VDE 0580

Voltage range $\pm 10\%$

100 % duty cycle

Protection class acc. to EN 60529 IP 65

(preferably DIN 40050)

Attention! Restricted temperature range for explosion proof solenoids.

For technical details see catalog register "Solenoids"

Further models

available at extra cost

- XX XXX **01.XXXX** Normally open, mounting position: solenoid vertical on top ³⁾
- XX XXX **02.XXXX** Manual override
- XX XXX **03.XXXX** Seat seal FPM, only ND 65 and larger ²⁾
- XX XXX **23.XXXX** Position indicator with two solenoid switches ³⁾
- XX XXX **34.XXXX** Enlarged closing force, advisable at low flow rate and low switching cycles
- **On request** Version for aggressive fluids, liquid fluids up to 80 mm²/s, Special connections e.g. ANSI, further versions

Power consumption ¹⁾

Solenoid	DC	AC Inrush and Holding
8301	22 W	–
8304	–	25 VA
8401	40 W	–
8404	–	45 VA
9501	80 W	–
9504	–	89 VA

Socket acc. to DIN 43650

AC solenoid with rectifier.

¹⁾ According to VDE 0580 at coil temperature +20 °C. In operating the solenoid coil decrease the power consumption appr. 30%.

- XX XXX XX.**8402** Solenoid for higher temperature, max. fluid temperature +200 °C, mounting position: vertical, with solenoid underneath, for DC only
- XX XXX XX.**8406** Same as 8402, for AC only
- XX XXX XX.**8436** Solenoid in protection class EEx me II T4
- XX XXX XX.**8441** Solenoid in protection class EEx me II T3
- XX XXX XX.**9502** Solenoid for higher temperature, max. fluid temperature +150 °C, from ND 65
- XX XXX XX.**9540** Solenoid in protection class EEx me II T3 and T4
- XX XXX XX.**8900** Solenoid in protection class EEx de IIC T4 and T5, up to ND 50
- XX XXX XX.**8920** Solenoid in protection class EEx d IIC T4 and T5, up to ND 50
- **On request** Overexcitation, solenoid in protection class EEx d I, EEx de I, special connections

²⁾ ND 15 up to 50 see series 85 240, publication 7502710

³⁾ ND 15 with solenoid 8401/8404

Sectional drawings

01

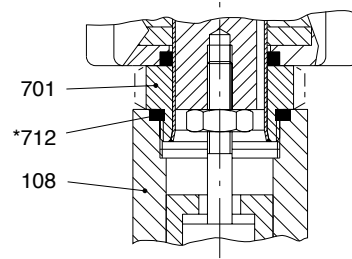
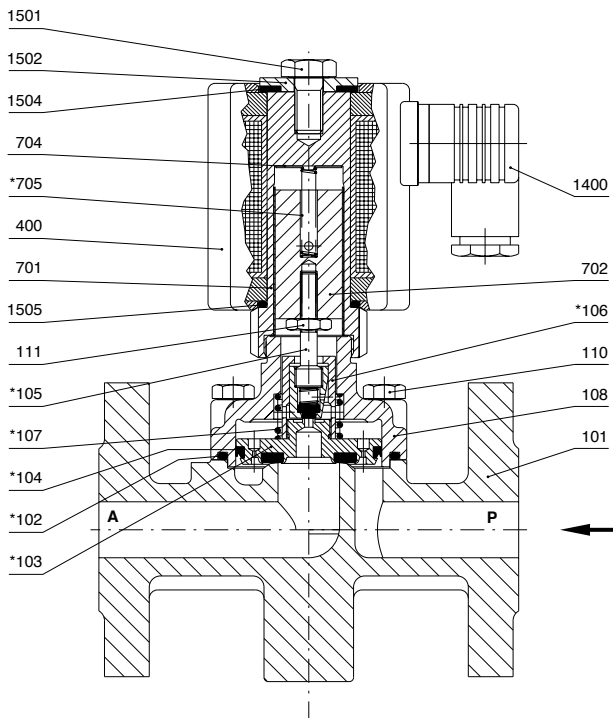

- | | |
|---|---------------------------------|
| 101 Valve body | 111 Hexagon nut |
| *102 Gasket | 400 Solenoid |
| *103 Valve plate | 701 Core tube |
| *104 Grooved ring | 702 Core |
| *105 Valve spindle | 704 Round plate |
| *106 Screw piece | *705 Pressure spring |
| *107 Pressure spring -
not for ND 15 | *712 Gasket -
only for ND 15 |
| 108 Body cover | 1400 Socket |
| 109 Spring washer -
only for ND 15
(not sketched) | 1501 Hexagon screw |
| 110 Hexagon screw | 1502 Round plate |
| | 1504 Gasket |
| | 1505 O-ring |

02

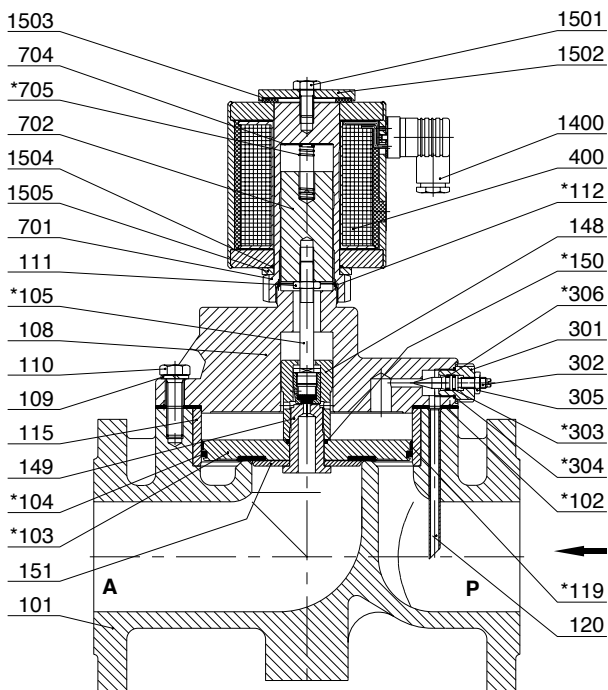

- | | |
|--------------------|----------------------|
| 101 Valve body | 301 Screw piece |
| *102 Gasket | 302 Valve spindle |
| *103 Valve plate | *303 O-ring |
| *104 Grooved ring | *304 O-ring |
| *105 Valve spindle | 305 Hexagon nut |
| 108 Body cover | *306 Grooved ring |
| 109 Spring washer | 400 Solenoid |
| 110 Hexagon crew | 701 Core tube |
| 111 Hexagon nut | 702 Core |
| *112 Gasket | 704 Round plate |
| 115 Bushing | *705 Pressure spring |
| *119 Guide foil | 1400 Socket |
| 120 Tube | 1501 Hexagon screw |
| 148 Screw piece | 1502 Round plate |
| 149 Screw piece | 1503 Gasket |
| *150 Gasket | 1504 O-ring |
| 151 Round plate | 1505 Round plate |

To avoid high shock pressure, you can control the closing time with the adjusting stem pos. 302. Turning clockwise pos. 302 increases restriction and slows down the speed. A totally closed restriction would result in a malfunction.

* These individual parts form a complete wearing unit.
When ordering spare parts please state
Cat no and series no.

Dimensions

01

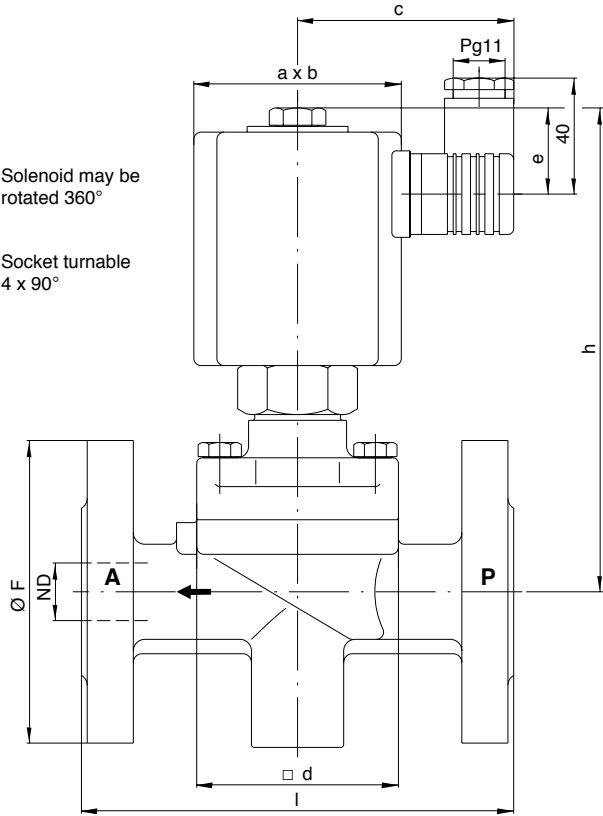

Flange connection PN 16 acc. to DIN 2543/2545
Contact face DIN 2526 type C

Dimension table no	a x b	c	□ a	e
01	52 x 65	65	70	26
02	72 x 92	75	70	31
03	72 x 92	75	70	31
04	72 x 92	75	96	31
05	72 x 92	75	96	31
06	72 x 92	75	112	31
Dimension table no	h	l	ND	Ø F
01	145	130	15	95
02	172	150	20	105
03	172	160	25	115
04	187	180	32	140
05	191	200	40	150
06	200	230	50	165

02

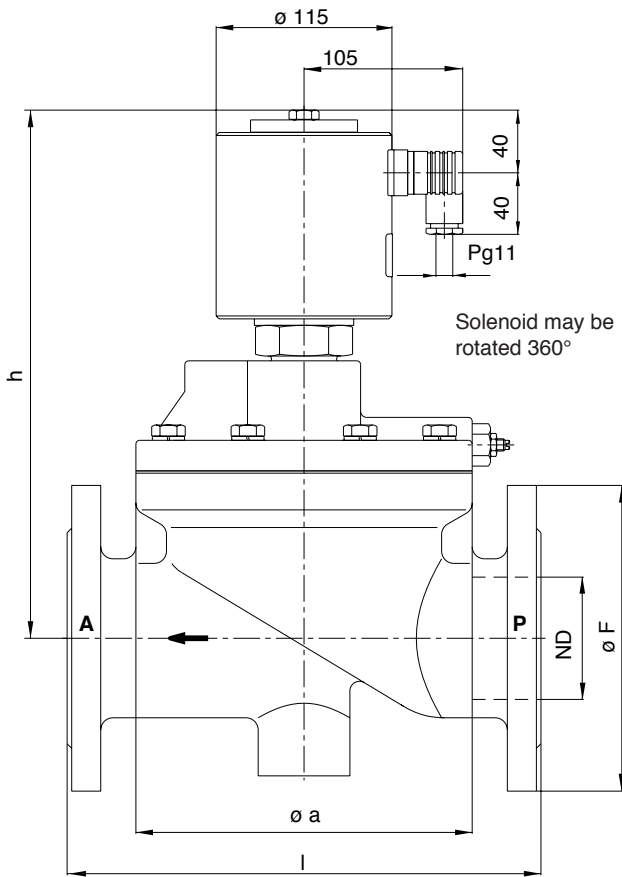

Flange connection PN 16 acc. to DIN 2543
Contact face DIN 2526 type C

Dimension table no	Ø a	h	l
07	195	330	290
08	220	350	310
09	260	378	350
Dimension table no	ND	Ø F	
07	65	185	
08	80	200	
09	100	220	