

Operating instructions - Rotary pneumatic controller 8287154

Document-No. EN8287154BA Revision 1

Keep documentation for future use!

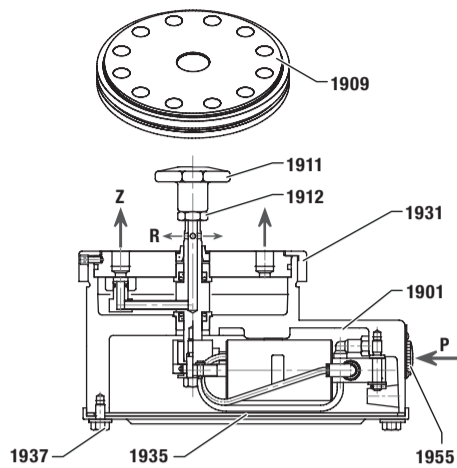

- 1911** Star knob
- 1912** Hexagon nut
- 1931** Screw piece
- 1901** Body
- 1955** Plug
- 1955** Body cover
- 1937** Tab screw (3x)
- 1909** Round plate (control disc)
- Z** Valve connections 12 x G 1/4
- R** Venting port
- P** Control port G 1/8

Ex II2 GD c IIB T85°C
Ex M2 c TÜV 04 ATEX 2606

Factory settings

| | |
|-----------------|------------------------------|
| Interval | adjustable 2 ... 200 seconds |
| factory setting | ca. 10 seconds |
| Pulse time | adjustable 30 ... 1.000 ms |
| factory setting | ca. 200 ms |

About this documentation

This operation manual guides you to mount the rotary pneumatic controller, to commission, to maintain and to replace parts and assemblies.

1.1 Documentation validity

This operation manual applies to pneumatic controller 8287054.0000.00000 with twelve valve connections.

This operation manual is intended for: distributor/operator, installers and service technicians.

1.2 Structure of safety instructions

Safety instructions warns against dangerous situations and must be observed in particular. Safety instructions are structured as follows:

SIGNAL WORD

Type of hazard

Consequences of non-observance

→ Precautions necessary to avoid the hazard

1.3 Hazard classes (ANSI Z535.6)

DANGER

Safety information indicates a hazardous situation with high risk which, if not avoided, will certainly result in death or (serious) injury.

WARNING

Safety information indicates a hazardous situation with moderate risk which, if not avoided, can cause death or severe injury.

CAUTION

Safety information indicates a hazardous situation on which, if not avoided, could result in minor or moderate injury.

NOTICE

Information indicates a hazardous situation which, if not avoided, could result damage to property.

1.4 Styles and symbols

| | |
|-------------|--------------------------------------|
| • | list |
| → | instruction |
| 1. | preset order of instructions |
| 2. | |
| 1911 | part number (according to part list) |
| 1 | part number (document) |

+ DANGER / WARNING / CAUTION;
NOTICE: embedded safety message

1.5 Intended use

The pneumatic controller is solely intended to control up to twelve dust filter cleaning valves. The pneumatic controller must only be operated with fluids that do not damage its constituent materials.

Consult our applications engineers if you have doubts whether the pneumatic controller is suitable for the intended purpose in permanent operation.

The pneumatic controller is suitable for use in these areas:

- areas with potentially explosive mixtures of gases and air (zones 1 and 2), or of dust and air (zones 21 and 22). This includes Equipment Category 2 and 3.
- in underground parts of mines and parts of surface installations of mines.

The Ex marking on the rating plate shows the operating limits.

The pneumatic controller is suitable for Group II gases and corresponds to article 4 (3) directive 2014/68/EU (pressure equipment device directive).

1.6 Improper use

In the following cases it is prohibited to operate the pneumatic controller:

- The pneumatic controller is used outside the permitted operating limits. The permitted temperature and pressure ranges are exceeded.
- Damages to the pneumatic controller – e.g. cracks, deformation – were detected but the pneumatic controller remains in operation.
- Malfunctions were detected but the pneumatic controller remains in operation.
- The pneumatic controller has been modified without authorization of the manufacturer.
- The safety instructions of this documentation are not observed.

1.7 Obligations of distributor/operator

- As distributor you are responsible that the pneumatic controller is mounted according to this operation manual. You are responsible that the operating limits are considered in designing the filter cleaning system.
- Ensure compliance with applicable laws, directives, regulations.

→ Ensure compliance with the following demands before persons mount, maintain or replace the pneumatic controller:

- This documentation must be fully read and understood.
- This documentation must be available at any time.
- Regulations about occupational safety and safety engineering must be known.

2 General safety instructions

These safety instructions are only related to the single pneumatic controller. In combination with other plant components there may be other potential dangers, which must be taken into account by carrying out a risk analysis for the system.

- Compare the details on the rating plate and the operating limits as shown in the datasheet to the operating data. The limits for the particular application must not be exceeded.

CAUTION

Injuries caused by moving parts

There is a danger of getting injured by moving parts, while the body cover is opened.

- Depressurize the plant/system prior to open body cover.

Residual risks

| | |
|--|---|
| | Weight of the pneumatic controller Phases: transport, storage, assembly, maintenance, disposal Risk: falling off, tipping over Personal protection equipment (PPE): protective footwear |
| | Sharp threads and edges Phases: transport, assembly, maintenance, disposal Risk: risk of cuts PPE: protective gloves |

3 Avoid damage to property

NOTICE

Damages through mechanical loads
The pneumatic controller may get damaged by external loads at the operating site.

- Protect the pneumatic controller from possible impact load.
- Secure the pneumatic controller against direct weather influences and the possible effects.

4 Identifying pneumatic controller

The rating plate is situated on the body of the pneumatic controller.

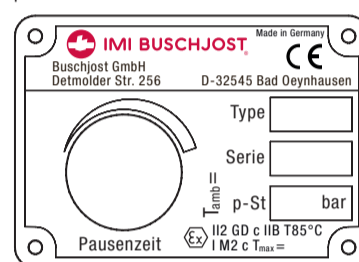

Rating plate (master)

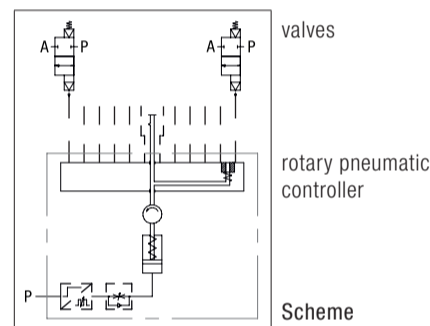

5 Transport and storage

- Only transport and store the pneumatic controller in its delivery packaging.
- Avoid mechanical loads: falling off, tipping.

6 Principle of operation

Design

Pneumatic controller with ratchet drive, employing pneumatic cylinder with return spring and interval controlled by pneumatic timer.

Throttle valve in pneumatic cylinder for speed of operating stroke (switching time of valve connection Z).

Operation

The unit is used for cyclical control of indirectly actuated valves with pilot pressure venting connection.

The pressure chamber of the pneumatic controller is pressurized via the valves' internal pilot ports and their pilot lines Z. Then the number of valves that are connected to the pressure chamber are closed.

The pressurization of the control port P causes the pneumatic cylinder to perform an idle stroke, and allows the pawl of the ratchet drive to engage one segment further on.

After the interval, the compression spring fitted in the cylinder produces an operating stroke. This moves the wiper arm 1907 over a valve connection Z. During this time the valve connected opens and closes again. This cycle is repeated as long as there is pressure at the control port P.

Manual override knob

The star knob 1911 can be used to switch the controller onwards manually during operation or when idle.

The mark on the star knob shows the position of the wiper arm.

7 Mounting

7.1 Ensure potential equalisation

The ground connection can be realized by mounting the unit directly at conducting parts of the system by using the lateral thread holes of the body 1901 of the pneumatic controller.

Also it is possible to connect an earth wire with a minimum wire cross section of 4 mm² there. The earth wire must be protected against corrosion, torsion and self-untightening to provide a permanent contact.

Special precautions must be taken if any contacted part is made of light metal. Use for example a steel-spacer.

7.2 Mount pneumatic controller

The pneumatic controller can be mounted in any position.

- Make sure that there is enough free space for dismantling the pneumatic controller in case of maintenance.
- **NOTICE** The step-by-step rotation moving of the star knob 1911 must not be interrupted by the laid pilot lines.
- **NOTICE** Take care that the position of the round plate 1909 will not change while mounting fittings at the pilot connectors Z.
- To achieve identical valve switching times, if possible use lines of identical length to connect them to Z.
- Unused valve connections Z must be sealed with threaded plugs.

7.3 Adjust switching time and interval

The switching time of the valves connected can be adjusted with the throttle valve fitted in the cylinder (beneath body cover).

- Screwing in throttle valve screw increases the switching time
- Unscrewing throttle valve screw decreases the switching time

This adjustment can only be carried out after removing the cover 1935. **CAUTION** There is a danger of getting injured by moving parts. Depressurize the plant/system prior to open body cover.

The interval can be adjusted on the outside of the timer, using the screw behind the plug 1955 in the name plate.

8 Operating conditions

| | |
|--|--|
| Pressure range | 0.5 to 8 bar |
| Control pressure | 2 to 8 bar |
| Fluid temperature | 0°C to +70°C |
| | -25°C to +70°C for dry air |
| Ambient temperature | -20°C to +40°C |
| Control pressure supply (port P): | Compressed air, filtered with pore size 5 to 10 µ, not lubricated. |
| Operating fluid (valve connections Z): | contaminated compressed air |

NOTICE Avoid significant pressure fluctuations – the interval of the pneumatic controller depends on the control pressure.

- reduction in pressure = shortening of interval
- increase in pressure = lengthening of interval

9 Commissioning

- **CAUTION** Ensure before commissioning that initial electrical actuation cannot give rise to danger from fluid escaping from unsecured openings. Prime the valve slowly when commissioning. The control chamber of the controller must reach operating pressure level before availability.

CAUTION Any surge in pressure will cause the opening of all connected valves.

- **WARNING** In explosive atmosphere the device must be connected to the system's earth wire.

- **WARNING** After adjusting the interval the hole at the rating plate must be closed with the plug to preserve the ex-dust protection.



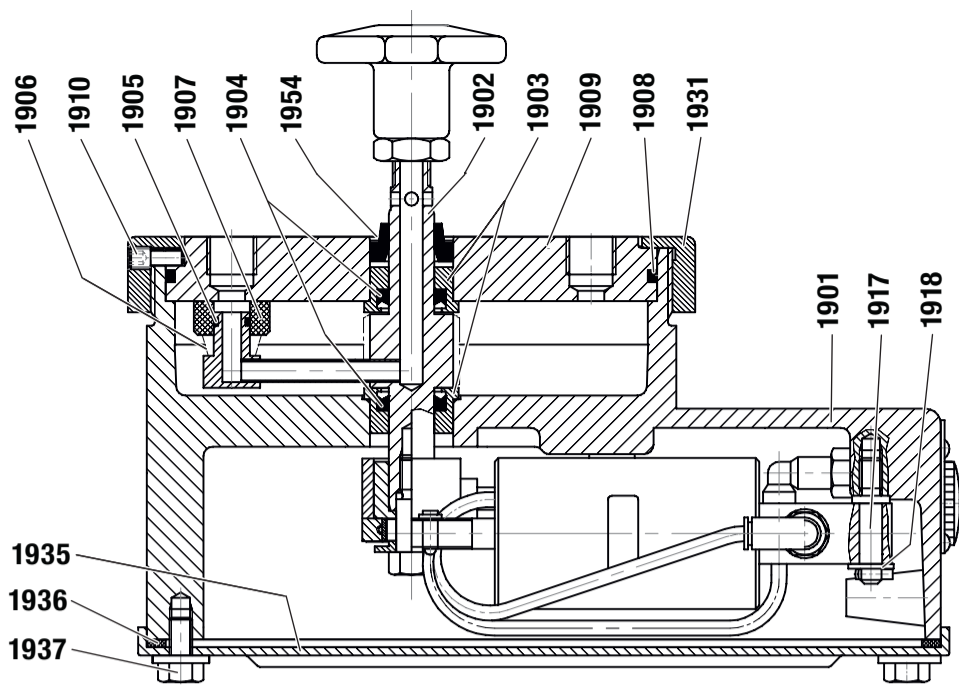

Sectional view of the pneumatic controller

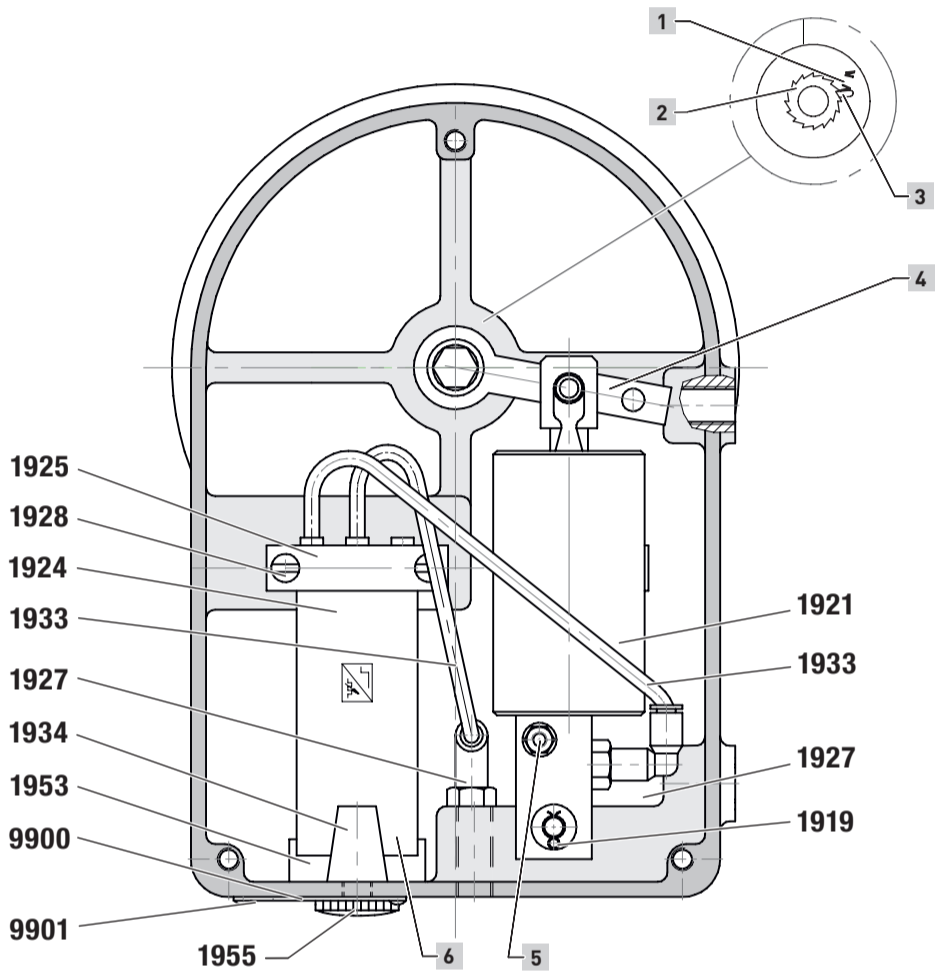

View of the pneumatic controller – body cover is lifted

Part number / Pieces / Designation

| | | | | | |
|------|---|------------------------------------|------|----|--------------------|
| 1900 | 1 | Pneumatic sequence controller | 1933 | 2 | Tube |
| 1901 | 1 | Body | 1934 | 1 | Sintered silencer |
| 1902 | 1 | Ratchet drive (wiper arm assembly) | 1935 | 1 | Body cover |
| 1903 | 1 | Collar bush | 1936 | 1 | Flat gasket |
| 1904 | 2 | Grooved ring | 1937 | 3 | Tab screw |
| 1905 | 1 | O-ring | 1953 | 1 | Flat gasket |
| 1906 | 1 | Compression spring | 1954 | 1 | Wiper ring |
| 1907 | 1 | Seal bush (wiper arm) | 1955 | 1 | Sealing plug K14 |
| 1908 | 1 | O-ring | 1959 | 1 | Collar bush |
| 1909 | 1 | Round plate | 9900 | 1 | Rating plate |
| 1910 | 1 | Grub pin | 9901 | 4 | Grooved drive stud |
| 1911 | 1 | Star knob | | | |
| 1912 | 1 | Hexagon nut | 1 | 1) | 1) |
| 1917 | 1 | Spindle | 1 | 1) | 1) |
| 1918 | 1 | Washer | 1 | 1) | 1) |
| 1919 | 1 | Split pin | 1 | 1) | 1) |
| 1921 | 1 | Pneumatic cylinder | 1 | 1) | 1) |
| 1924 | 1 | Pulse generator | 1 | 1) | 1) |
| 1925 | 1 | Elbow hose push-in connector | 1 | 1) | 1) |
| 1928 | 2 | Slotted cheese head screw | 1 | 1) | 1) |
| 1931 | 1 | screw piece | 1 | 1) | 1) |

10 Maintenance

Maintenance work may only be carried out by trained personnel.

- Buschjost recommends preventive maintenance depending on operating conditions.
- Deposits, dirt, perished or worn seals lead to malfunctions.
- Recommended parts subject to wear are indicated with 1) in the parts list.
- The attached drawing shows the position in which the parts are to be fitted.

⚠ WARNING Maintenance work may only be carried out with the system depressurized and the controller disconnected from the control pressure supply.

11 Replacing parts and assemblies

11.1 Replace pneumatic timer 1924

1. Undo bolts **1937** and remove cover **1935**.
2. Undo screws **1928** and remove timer with base plate **1925**. Control lines can remain connected.
3. Unscrew timer **1924** from base plate **1925**, replace and screw down again.
4. Screw base plate and timer in the body again with screws **1928**. Ensure the foam deal **1953** is seated properly.
5. Refit cover **1935** and screw down with bolts **1937**.

11.2 Replace pneumatic cylinder 1921

1. Undo bolts **1937** and remove cover **1935**.
2. Remove control line from the pneumatic cylinder after depressing the connector's release ring.
3. Remove split pin **1919** and washer **1918**.
4. Remove pin retaining clip from the yoke and pull pin out.
5. Push ratchet lever **4** out of the yoke. Pull pneumatic cylinder off support pin **1917**. Unscrew elbow **1927** and fit to new pneumatic cylinder.
6. Put new pneumatic cylinder on the support pin **1917** first, and then introduce the ratchet lever **4** into the yoke. Insert pin and secure.
7. Slip washer **1918** over the support pin and secure with split pin **1919**.
8. Push control line fully home in the elbow hose push-in connector **1927**. Check that line firmly seated by pulling it.
9. Refit cover and screw down with bolts **1937**.

11.3 Replace ratchet drive 1902

1. Undo bolts **1937** and remove cover **1935**.
2. Remove pin retaining clip from the yoke of the pneumatic cylinder and pull pin out. Push ratchet lever **4** out of the yoke. Unscrew hexagon bolt **5** (caution: left-handed thread), steadying with star knob **1911** or with mandrel in the venting ports of the wiper arm assembly. Remove ratchet lever **4** and put loose parts in a safe place to prevent them getting lost.
3. Replace gear wheel **1**, pawl **3** and compression spring **2**.
4. Put ratchet lever **4** on again and hand-tighten with hexagon bolt **5**.
5. Introduce ratchet lever **4** into yoke and secure with pin.
6. Use the star knob **1911** to turn the wiper arm **1907** clockwise to a position midway between any two valve connections **Z**, and tighten hexagon bolt **5** on the ratchet drive.
7. Check position of the wiper arm **1907** during test run, and readjust as described above if necessary.
8. Refit cover **1935** and screw down with bolts **1937**.

11.4 Replace wiper arm 1907

1. Release hexagon nut **1912** and unscrew together with star knob **1911**.
2. Slacken off grub screw **1910** and unscrew threaded ring **1931**.
3. Pull off control disc **1909** (use threads of valve connections for pulling).
4. Replace compression spring **1906**, O-ring **1905**, wiper arm **1907** and O-ring **1908**.
5. Replace control disc **1909** and screw threaded ring **1931** on without seating firmly.
6. Fit star knob **1911** with mark at position of wiper arm, and lock with hexagon nut **1912**. Turn star knob clockwise until resistance felt from the pawl in the ratchet drive. With the wiper arm assembly in this position, adjust the control disc **1909** by turning clockwise, so that the wiper arm is midway between two valve connections **Z**. (Visual inspection through the valve connections).
7. Tighten threaded ring **1931** and lock with grub screw **1910**.

12 Operating and leak test

It is advisable to carry out an operating and leak test after performing maintenance work.

- Check the control line connections for leaks.
- Check whether the wiper arm assembly is leaking.
- Check whether the wiper arm is leaking at the venting ports **R** of the wiper arm assembly.

Procedure

- This is achieved by connecting at least one valve to connection **Z**, so that the controller's chamber is pressurized with compressed air. Seal the other connections with threaded plugs.
- Readjust the position of the wiper arm in the event of leakage.
- Operating test to adjust interval and switching time.

13 Trouble shooting

| |
|---|
| Wiper arm assembly turning backwards and forwards |
| Possible cause: No pressure at the valve connections Z . (wiper arm assembly friction too low, ratchet drive not turning assembly) |
| Remedy: The connected valves must be pressurized with the operating pressure. |
| Wiper arm assembly not moving on to the next valve connection |
| Possible cause: Interval set too short. Pneumatic cylinder not reaching the limit of the stroke. Ratchet drive not turning assembly. |
| Remedy: Increase timer interval until the wiper arm assembly moves on properly. |
| Possible cause: Control pressure P and Z are connected to the same source. |
| Remedy: When the valves are switched via their connections Z the pressure in the tank drops sharply, and the control pressure at P is no longer sufficient to extend the pneumatic cylinder to the limit of its stroke. Moreover, the timer's interval shortens when the pressure is considerably reduced. |
| Controller not switching |
| Possible cause: Pneumatic timer 1924 dirty. |
| Remedy: Replace timer. Fine filter (5 to 10 µ) at port P , air must not be lubricated. |
| Possible cause: Pneumatic cylinder 1921 faulty. |
| Remedy: Replace pneumatic cylinder. |
| Air loss from venting port R of the wiper arm assembly during the interval |
| Possible cause: Angular misalignment between the ratchet drive 1902 and the control disc 1909 . |
| Remedy: Align control disc 1909 so that during the interval the wiper arm 1907 is exactly between two valve connections Z . Be careful to slacken off grub screw 1910 and threaded ring 1931 beforehand. |
| Possible cause: Wiper arm 1907 worn. |
| Remedy: Replace wiper arm. |

14 Decommissioning

- Comply with applicable safety precautions. Strictly observe the local safety regulations of the overall plant during decommissioning irrespective of the instructions below.
- 1. **⚠ WARNING** Make sure that the compressed air poses no potential hazard. Depressurize the filter cleaning system prior to decommissioning the pneumatic controller.
- 2. Unmount the pneumatic controller from the filter cleaning system.

15 Disposal

- Dispose pneumatic controller after decommissioning. Follow the ideas of recycling and environmental sustainability.
- Unmount the pneumatic controller from the plant/system. Dismantle the pneumatic controller and lead recyclable materials to proper recycling:

| Material | Way of disposal |
|-----------------------------------|--|
| Body, screw piece, -round plate | Solid metal scrap |
| Cover, internal parts from metal | Metal recycling |
| Sealings, star knob, sealing plug | Industrial waste (similar category to domestic refuse) |



Buschjost GmbH
 Detmolder Str. 256
 D-32545 Bad Oeynhausen
 Box 10 02 52-53
 D-32502 Bad Oeynhausen
 Phone: 0 57 31/7 91-0
 Fax: 0 57 31/79 11 79
 www.imi-precision.com
 buschjost@imi-precision.com

