



1.1 GENERAL OVERVIEW

Norgren manufactures two main types of lubricators: Oil-Fog and Micro-Fog. These units are mounted directly into the pipe and add small amounts of oil to the air flowing through them.

Oil Fog-Lubricators:

All the oil droplets seen in the sight dome are added directly into the air flow. This results in relatively large oil droplets passing downstream, suitable for heavy lubrication applications eg single cylinders and tools. Most competitive in line lubricators are of the Oil-Fog type.

Micro-Fog Lubricators:

The oil droplets seen in the sight dome are atomized and collected in the area above the oil in the bowl. The smaller lighter particles are drawn into the air flow and pass downstream.

As a result typically only 10% of the oil seen as drops in the sight dome is passed downstream. The remainder falls back into the oil reservoir. Consequently, drip rate settings are somewhat higher than their Oil-Fog equivalent. This makes setting much easier, particularly in low flow applications.

The fine Micro-Fog oil particles can travel long distances through complex pipe work making Micro-Fog lubricators suitable for multiple valve and cylinder circuits.

1.2 WHAT ARE THE DIFFERENCES BETWEEN MICRO-FOG AND OIL-FOG?

1.2.1 Oil-Fog:

- Large oil particles not as fine as micro-fog.
- All oil drips seen in sight domes are delivered downstream.
- For applications over short distances.
- Should be mounted at same level or higher than device being lubricated.
- Standard bowls can be filled under pressure. (Not on rapid cycle units).
- Suitable for heavy lubrication applications eg single large cylinders and tools.
- Has a flow sensor which provides constant oil output density for varying flows.

OIL-FOG LUBRICATOR

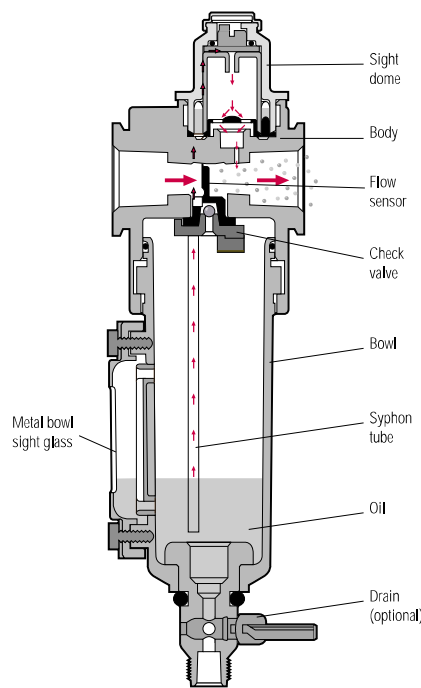

1.2.2 Micro-Fog:

- Small oil particles; less than 2 micron.
- Only 10% of 'drip rate' is delivered downstream as active lubricant (remainder is returned to main oil reservoir).
- High drip rates make drip setting easier in low flow applications.
- Can be mounted above or below the point of application.
- Cannot be filled without shutting off upstream air (unless a quick fill cap or remote fill device is used).
- For use with lengthy air lines, multiple valve and cylinder circuits.
- Has a flow sensor to provide an almost constant oil output density for varying flows.

1.2.3 Can Oil-Fog and Micro-Fog Units be Converted?

Generally not, simply changing a green (Oil-Fog) sight dome for a red (Micro-Fog) sight dome does not change the function.

Some lubricators are designed around a cartridge insert. In this case it may be possible to swap the cartridge and sight domes to change the function.

MICRO-FOG LUBRICATOR

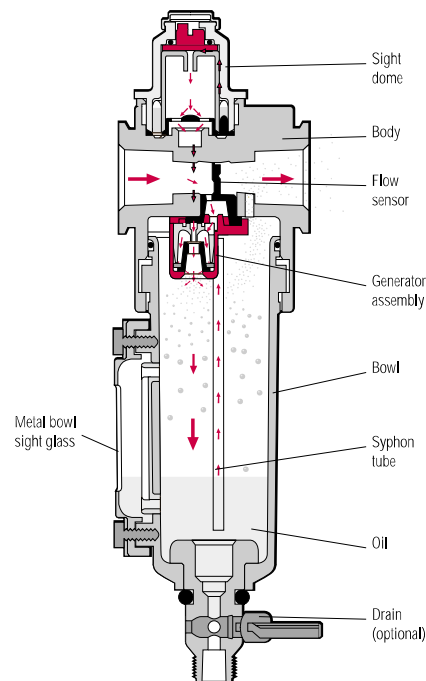

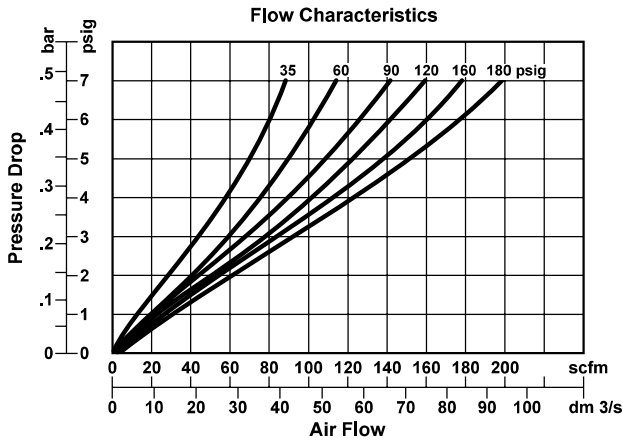

1.3 LUBRICATOR SIZING

Lubricators are sized by downstream flow requirements. An analysis of air flow use must be made. After determining how much air flow is needed, a lubricator can be chosen. Manufacturers' curves will be like the one shown. For example, 50 scfm of 90 psig lubricated air is required. Enter the curve on the horizontal axis at the required flow. Read up to intersect the 90 psig line. Read the pressure drop on left, vertical axis as approximately 2.3 psid. Pressure drop should be less than 5 psid. If pressure drop is more than 5 psid, choose a larger lubricator.

Always be sure that the lubricants in your system are compatible with the materials in the lubricator you choose. This is especially important for plastic lubricator reservoirs. If in doubt, check with the factory or use a metal reservoir.

1.4 SETTING LUBRICATOR DRIP RATES

1.4.1 What is the Correct Drip Rate Setting?

The drip rate will depend on the application, the amount of lubrication required, the flow through the lubricator and the lubricator type. In **Micro-Fog** lubricators only 10% of the droplets in the sight dome are carried downstream. The drip rate in Micro-Fog lubricators therefore tends to be much higher.

The following table can be used to estimate drip rate for required flow. This is very much a rule of thumb. In practice it is necessary to fine tune the oil drip rate in each application.

Typical Drip Rate per Minute Micro-Fog	Typical Drip Rate per Minute Oil-Fog	Approx Flow scfm (dm ³ /s)
20	2	10 (5)
40	4	20 (10)
60	6	30 (15)
80	8	40 (20)
100	10	50 (25)
120	12	60 (30)

1.3.2 Can the Drip Rate be Shut Off?

In lubricators with needle valve type sight dome, yes.

Some Norgren sight domes use a felt pad which is soaked in oil at the point where the drops are formed. With this type of sight dome the oil droplets cease once the felt pad dries out.

With the new style dome (L72/73/74 and L07) complete shut off is not possible. Minimum adjustment for the drip rate is around 1 drop per minute.

1.5 FILLING METHODS

1.5.1 Oil-Fog and Micro-Fog Lubricators:

The standard Oil-Fog lubricators can be filled under pressure ie without switching off the upstream air. When a fill plug is removed a check valve in the lubricator body isolates the inlet pressure from the bowl and the reservoir will depressurize. The lubricator can then be filled with oil. When the fill plug is replaced, the reservoir will re-pressurize.

The standard Micro-Fog unit can only be filled without isolating the upstream pressure if a remote fill or quick fill nipple accessory is fitted. To remove the fill plug of a Micro-Fog lubricator whilst under pressure can be dangerous. If in doubt shut off the upstream air!

1.5.2 Remote Fill Devices:

The remote oil fill system provides a means of filling from a remote fill point, a single lubricator or a bank of lubricators manifolded together. The remote fill point may be connected to a portable reservoir or to a centralized, permanent reservoir. A portable reservoir permits the use of different lubricants in different groups of lubricators to suit the requirements of the machinery being lubricated. The lubrication oil must be fed in at a higher pressure than exists in the bowl.

The devices are NOT intended for connection to an oil feed line which is under constant pressure from a pump or pressurized reservoir. The device cannot reset until the pressure is removed. Such lines are a potential safety hazard if they should leak or become broken.

1.5.3 Quick Fill Nipples:

The quick fill system is an alternative which allows ease of filling a single Micro-Fog or Oil-Fog lubricator without switching off the mains air (on some units the quick fill nipple replaces the filler plug).

To fill the lubricator, a quick fill connector piped to a portable oil reservoir is snapped in place over the quick fill nipple. The main oil reservoir can now be pumped (or pressurized) to a pressure greater than the lubricator bowl and the lubricator filled.



1.6 OPTIONS AND ACCESSORIES

1.6.1 Where can Liquid Level Switches be Fitted?

Liquid level detection methods can be attached to the 1 quart bowl and 2 & 5 gallon tanks.

1.6.2 Where can Remote Fill and Liquid Level Switches be Fitted?

The smaller bowls, L73 and up, are all capable of either remote fill or liquid level detection (but not both at the same time!). The 2 quart and 2 & 5 gallon tanks only can have the liquid level switches fitted.

1.6.3 How do Liquid Level Switches Work?

Liquid level switches are bipolar reed switches which change state when the float rises and falls.

Liquid level switches are normally connected to give an electrical signal when the float falls (ie when the liquid level is too low). In critical applications the logic could be reversed. Maximum and minimum settings are possible too.

1.7 LARGE TANKS/RESERVOIRS

1.7.1 Which Units have Large Tanks/Reservoirs?

All units in basic 1/2" and above have optional larger bowls/tanks.

Olympian Plus and Excelon 74 are limited to 1 quart as standard. For 2 and 5 gallon capacity use 15/17 Series, or the 10-028/-076 (2") lubricators.

1.8 APPLICATION SPECIFIC UNITS

1.8.1 Do we Make Bearing Lubricators?

These are aerosol type lubricators. These lubricators use air to get the oil to the point of lubrication, however the tool or application is not powered by the air. Although produced by Norgren, systems for their application are designed and sold by Engineering and General Lubrication Systems.

1.8.2 What is a Fixed Venturi (Bi-Directional) Lubricator?

Standard Norgren lubricators use a flow sensor to achieve constant oil density with varying flows. In some applications high flow is more important than constant density and a fixed venturi can be used instead of a flow sensor. It may also be useful in systems with rapid cycling. Consult Air Line for more details.

1.9 OILS

1.9.1 What Oils are Recommended?

Recommended oils fall into 2 categories:-

- 1 Oils recommended for use with all Norgren units (valves, cylinders, fittings and FRL's).
- 2 Oils which can be used with Norgren lubricators but not necessarily with other Norgren equipment.

Refer to ALE-29-2 for recommended lubricants.

1.9.2 Can Non-Recommended Oils be Used?

Some oils can be tested for suitability, but Norgren cannot be responsible for use of non-recommended lubricants.



1.10 SIMPLE LUBRICATOR TROUBLESHOOTING

Problem	Possible Cause	Remedy
No Drip Rate	Oil adjustment knob fully clockwise.	Readjust knob.
	Low oil level.	Check oil level.
	Airflow through lubricator too low.	Use smaller size lubricator. Remove bowl and sight feed adjustment dome and clear syphon tube.
	Blocked oil filter screen.	Remove sight feed adjustment dome and clean or replace screen located in dome assembly.
	Air leaks.	Check bowl, filler plug and sight dome seals. Tighten if necessary.
Oil Foaming	Over aeration.	Check bowl seals for slight leaks.
Oil Emulsified	Water in lubricator.	Fit filter immediately upstream.
Drip Rate changes after setting	Fade.	Readjust drip rate.

Excelon 73 Micro-Fog and Oil-Fog Lubricators 1/4", 3/8", 1/2" Port Sizes

- Excelon design allows in-line or modular installation
- Quick release bayonet bowl
- Flow sensor design provides a nearly constant oil/air ratio over a wide range of air flows
- Highly visible, prismatic liquid level indicator lens
- All around (360°) visibility of the sight-feed dome simplifies installation and adjustment
- Modular installations with Excelon 72, 73, and 74 series can be made to suit particular applications

Use Micro-Fog models in applications containing one or more points of lubrication.

Use Oil-Fog models to lubricate a single tool, cylinder, or other air driven device.



Ordering Information. Models listed include PTF threads, manual drain, and metal bowl with plastic liquid level indicator.

Type	Main Port Size	Model Number	Flow* scfm (dm ³ /s)	Weight lb (kg)
Micro-Fog	1/4"	L73M-2AP-QDN	60 (28)	1.1 (0.50)
	3/8"	L73M-3AP-QDN	60 (28)	1.1 (0.50)
	1/2"	L73M-4AP-QDN	60 (28)	1.1 (0.50)
Oil-Fog	1/4"	L73C-2AP-QDN	60 (28)	1.1 (0.50)
	3/8"	L73C-3AP-QDN	60 (28)	1.1 (0.50)
	1/2"	L73C-4AP-QDN	60 (28)	1.1 (0.50)

* Maximum recommended air flow. Higher flows create excessive air velocity, turbulence, and pressure losses.

Alternative Models

L 7 3 ★ - ★ ★ ★ - ★ ★ ★

Type	Substitute
Oil-Fog	C
Micro-Fog	M
Port Size	Substitute
1/4"	2
3/8"	3
1/2"	4
Threads	Substitute
PTF	A
ISO Rc taper	B
ISO G parallel	G
Air Flow Direction	Substitute
Uni-directional	P

Options	Substitute
None	N
Pyrex sight-feed dome †	P
Quick fill nipple	Q

Bowl	Substitute
Metal with plastic liquid level indicator	D
Transparent with guard	P
Metal with Pyrex liquid level indicator†	R
Transparent	T

Drain	Substitute
Closed bottom	E
Manual 1/4 turn	Q

† Order optional Pyrex sight-feed dome when ordering metal bowl with Pyrex liquid level indicator.

See Section ALE-25 for Accessories



Technical Data

Fluid: Compressed air

Maximum pressure

Transparent bowl: 150 psig (10 bar)

Metal bowl: 250 psig (17 bar)

Operating temperature*

Transparent bowl: 0° to 125°F (-20° to 50°C)

Metal bowl: 0° to 175°F (-20° to 80°C)

* Air supply must be dry enough to avoid ice formation at temperatures below 35°F (2°C).

Start point (minimum flow required for lubricator operation): 1.5 scfm (0.71 dm³/s) at 90 psig (6.3 bar) inlet pressure

Typical flow with 90 psig (6.3 bar) inlet pressure and 3.5 psig (0.25 bar) pressure drop: 80 scfm (38 dm³/s)

Maximum recommended flow: 60 scfm (28 dm³/s). Air flows above 60 scfm (28 dm³/s) create excessive air velocity, turbulence, and pressure losses. In addition, the fog produced by the lubricator will wet out on the pipe walls and will not be carried by the compressed air to the point of application.

Nominal bowl size: 3.5 fluid ounce (0.1 liter)

Manual drain connection: Will fit 1/8-27 and 1/8-28 pipe thread

Recommended lubricants: See Section ALE-29.

Materials

Body: Aluminum

Bowl

Transparent: Polycarbonate

Transparent with guard: Polycarbonate, steel guard

Metal: Aluminum

Metal bowl liquid level indicator lens: Transparent nylon

Sight-Feed dome: Transparent nylon

Elastomers: Neoprene and nitrile

All Dimensions in Inches (mm)

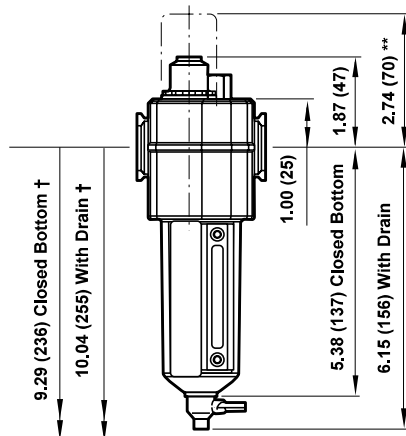
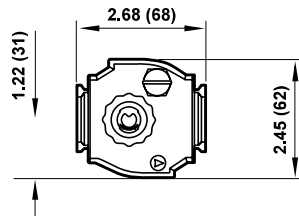

** Optional pyrex sight-feed dome.

† Minimum clearance to remove bowl.

Typical Performance Characteristics

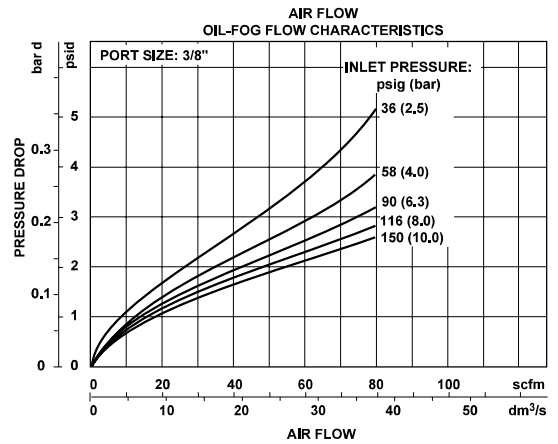
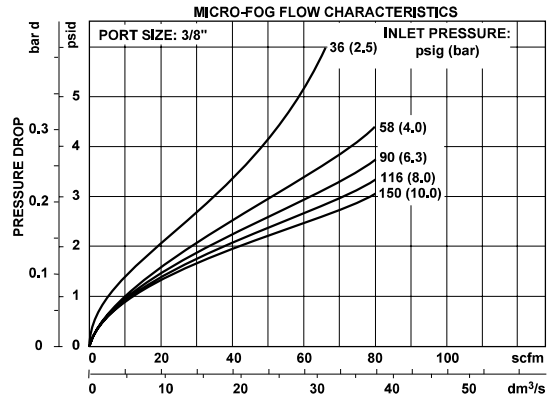

Service Kits

Item	Type	Part Number
Service kit	Seal & Gasket	4382-600
Liquid level lens kit	Prismatic	4380-020
Replacement drain	Manual 1/4 turn	619-50

Service kit includes dome seal, drain seal, bowl seal and fill plug seal.