

**SMART-Cylinders**  
**ISO 6431, VDMA 24562 and NFE 49-003-1**  
**Magnetic piston**  
**Double acting**  
**Ø 32 to 100 mm**

**Conforms to ISO 6431 and VDMA 24562**  
**Complete functional unit with LED display**  
**Integrated AS-i Bus or multipole connector**  
**Integrated 5/2 or 5/3 valve with different functions**  
**Flow regulator for speed control as standard**  
**Integrated reed or solid state switch**  
**Profile with concealed tie rods**  
**Comprehensive range of standard VDMA mountings**



**Technical data:**

**Medium:**  
 Compressed air, filtered, lubricated or non-lubricated

**Standard:**  
 ISO 6431, VDMA 24562

**Operation:**  
 Double acting, adjustable cushioning, magnetic piston and flow regulators

**Operating pressure:**  
 2 to 8 bar

**Operating temperature:**  
 -5°C to + 50°C

Consult our Technical Service for use below +2°C

**Strokes:**  
 Up to 1000 mm max.

**Speed:**  
 Ø32 to 80 mm: max 1,5 m/s  
 Ø100 mm: max 1,0 m/s

**Protection rating:**  
 IP 65, IP 67 on request

**Material:**  
 Profile barrel: anodised aluminium  
 End covers: anodised aluminium  
 Piston rod: stainless steel (Martensitic)  
 Piston rod seals: polyurethane  
 Piston seals and O-rings: nitrile rubber  
 Spool and sleeve: anodised aluminium with special coating

**Ordering examples**

See page 2

**Mountings and accessories**

See page 4

**Guide blocks**

QA/8000/61 – Roller bearing

See pages 14 and 15

**Drawings**

2D & 3D CAD

See [www.norgren.com](http://www.norgren.com)

**Technical support**

[Smart-Zylinder@Norgren-Herion.de](mailto:Smart-Zylinder@Norgren-Herion.de)

SMART-Cylinder with AS-Interface Bus System

SMART-Cylinder with Multipole connection

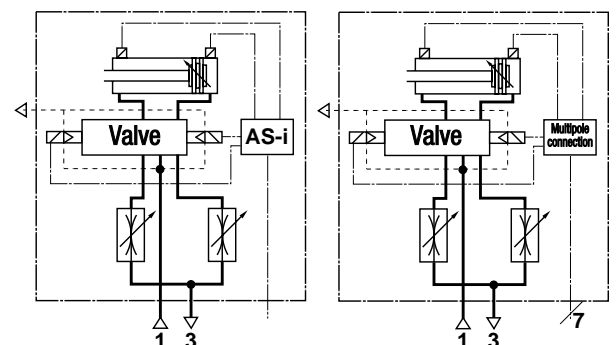

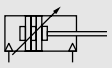
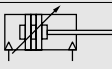
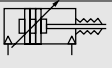
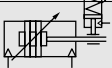

## Cylinder variants

Symbol	Model	Description	Dimensions Page
	PRA/282000/MI	Standard cylinder	5
	PCA/282000/MI	Cylinder with hard chromium plated piston rod	5
	PSA/282000/MI	Cylinder with stainless steel piston rod (Austenitic)	5
	PRA/282000/MU	Cylinder with extended piston rod	5
	PRA/282000/MG	Cylinder with piston rod bellows	6
	PRA/282000/L4	Cylinder with locking unit (passive). Locking is achieved by spring force on removal of the signal to the unit. Operating pressure for locking unit: 4 to 10 bar	6

## Model codes

P \* A / 282 \* \* \* / \* \* \* \* / \* \* / \* \* \* \* \*

Piston rod material	Substitute
Stainless steel (Martensitic)	R
Hard chromium plated	C
Stainless steel (Austenitic)	S

Cylinder diameters (mm)	Substitute
032, 040, 050, 063, 080, 100	

Pneumatic variants	Substitute
Standard	MI
Piston rod bellow	MG
Locking unit	L4
Extended piston rod	MU
P*A/282***/**/MU*/****/*	Extension (mm)

Valve variants	Substitute
5/2 Sol/spring (cylinder instroke)	R
5/2 Sol/spring (cylinder outstroke)	E
5/2 Sol/sol (Bistable)	B
5/3 Sol/sol (APB)	A
5/3 Sol/sol (COE)	C

Strokes (mm)
1000 max

Electric variants	Substitute
AS-i Bus, Reed switch M/50/LSU (east)	A1
AS-i Bus, Solid state M/50/EAP (east)	A2
AS-i Bus, Reed switch M/50/LSU (west)	A3
AS-i Bus, Solid state M/50/EAP (west)	A4
AS-i Bus, external power, reed switch M/50/LSU (east)	B1
AS-i Bus, external power, solid state M/50/EAP (east)	B2
AS-i Bus, external power, reed switch M/50/LSU (west)	B3
AS-i Bus, external power, solid state M/50/EAP (west)	B4
Multipole connector, reed switch M/50/LSU (east)	M1
Multipole connector, solid state M/50/EAP (east)	M2
Multipole connector, reed switch M/50/LSU (west)	M3
Multipole connector, solid state M/50/EAP (west)	M4

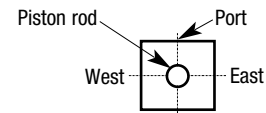

Note: Disregard option positions not used.  
For combinations of cylinder variants consult our Technical Service.

## Ordering examples

### Cylinder

To order a standard 80 mm bore magnetic piston cylinder with a 50 mm stroke, 5/2 valve solenoid/spring, cylinder instroke, with multipole connector and reed switches M/50/LSU, position east  
Quote: **PRA/282080/MIR/M1/50**

### Mounting

To order a front flange mounting style 'G' for 80 mm bore  
Quote: **QA/8080/22**

### Cylinder

To order a standard 50 mm bore magnetic piston cylinder with a 150 mm stroke, 5/2 solenoid/solenoid, bistable with AS-i Bus and reed switch M/50/LSU, position east Quote: **PRA/282050/MIB/A1/150**

### Mounting

To order a foot mounting style 'C' for 50 mm bore  
Quote: **QA/8050/21**



### Example: PRA/282000/MIR/A. AS-Interface-Bus System

Complete functional unit with LED display and integrated AS-i Bus  
Conforms to ISO 6431 and VDMA 24562

Flexible open system

Hand held function available

Easy installation: Only 1 pneumatic and 1 electric connection

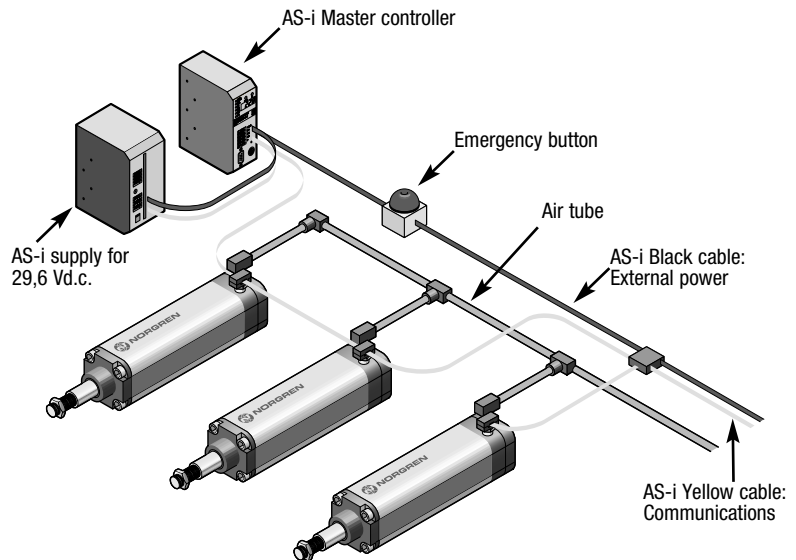

#### Technical data:

Supply voltage:  
24 V d.c.

AS-i connection:  
M12 male 4 pin

ID-Code AS-Interface:  
F

IO-Code AS-Interface:  
3

Cable:  
AS-i  
Yellow: Communications  
Black: External power (optional)

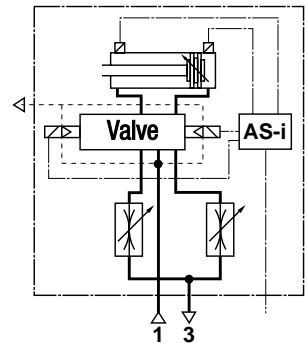

### Example: PRA/282000/MIR/M. Multipole connection

Complete functional unit with LED display and multipole connection

Conforms to ISO 6431 and VDMA 24562

Fieldbus compatible 24 V d.c.

Hand held function available

Quick and easy installation

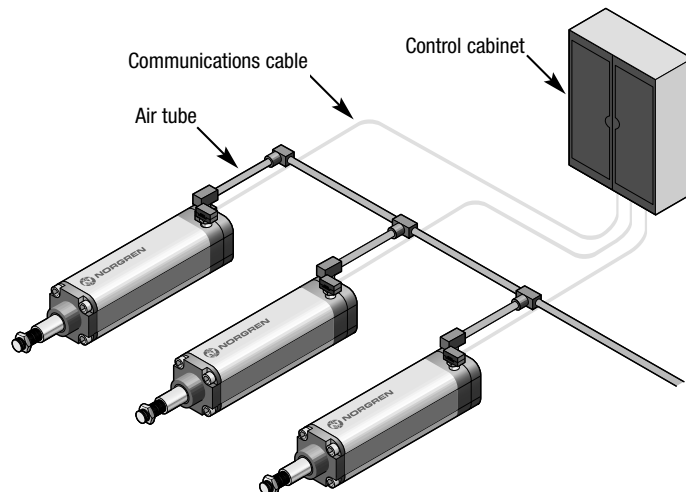

#### Technical data:

Supply voltage:  
24 V d.c.

Multipole connection:  
M12 male 8 pin

Max. power consumption:  
1 W per coil

Rating:  
100 % E.D.

Electrical protection:  
Fly-wheel diode

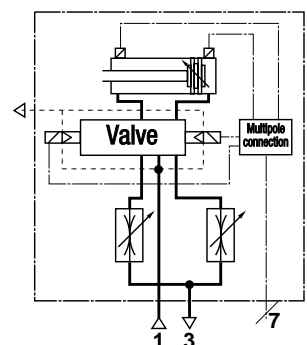



## Mountings for cylinders

	A	AK	B, G	C	D	D2	F
	Y 7						
Ø	Page 7	Page 13	Page 7	Page 7	Page 9	Page 10	Page 8
32	QM/8032/35	QM/8025/38	QA/8032/22	QA/8032/21	QA/8032/23	QA/8032/42	QM/8025/25
40	QM/8032/35	QM/8040/38	QA/8040/22	QA/8040/21	QA/8040/23	QA/8040/42	QM/8040/25
50	QM/8050/35	QM/8050/38	QA/8050/22	QA/8050/21	QA/8050/23	QA/8050/42	QM/8050/25
63	QM/8050/35	QM/8050/38	QA/8063/22	QA/8063/21	QA/8063/23	QA/8063/42	QM/8050/25
80	QM/8080/35	QM/8080/38	QA/8080/22	QA/8080/21	QA/8080/23	QA/8080/42	QM/8080/25
100	QM/8080/35	QM/8080/38	QA/8100/22	QA/8100/21	QA/8100/23	QA/8100/42	QM/8080/25
	FH	L	M	R	S	SS	SW
Ø	Page 12	Page 9	Page 8	Page 11	Page 12	Page 08	Page 9
32	QA/8032/34	QA/8032/24	QM/8032/26	QA/8032/27	QA/8032/41	M/P19931	M/P19493
40	QA/8040/34	QA/8040/24	QM/8040/26	QA/8040/27	QA/8040/41	M/P19932	M/P19494
50	QA/8050/34	QA/8050/24	QM/8050/26	QA/8050/27	QA/8040/41	M/P19933	M/P19495
63	QA/8063/34	QA/8063/24	QM/8063/26	QA/8063/27	QA/8063/41	M/P19934	M/P19496
80	QA/8080/34	QA/8080/24	QM/8080/26	QA/8080/27	QA/8063/41	M/P19935	M/P19497
100	QA/8100/34	QA/8100/24	QM/8100/26	QA/8100/27	QA/8100/41	M/P19936	M/P19498
	UF	UL	UR	US	Guide blocks ##	Locking unit #	
Ø	Page 13	Page 10	Page 11	Page 10	Page 14	Page 6	
32	QM/8025/32	QA/8032/43	QA/8032/33	M/P40310	QA/8032/61/*	QA/8032/59	
40	QM/8040/32	QA/8040/43	QA/8040/33	M/P40311	QA/8040/61/*	QA/8040/59	
50	QM/8050/32	QA/8050/43	QA/8050/33	M/P40312	QA/8050/61/*	QA/8050/59	
63	QM/8050/32	QA/8063/43	QA/8063/33	M/P40313	QA/8063/61/*	QA/8063/59	
80	QM/8080/32	QA/8080/43	QA/8080/33	M/P40314	QA/8080/61/*	QA/8080/59	
100	QM/8080/32	QA/8100/43	QA/8100/33	M/P40315	QA/8100/61/*	QA/8100/59	

\* Insert standard stroke length (50, 100, 160, 200, 250, 320, 400 or 500) in mm. Consult our Technical Service for stroke lengths above 500 mm.

# For locking cartridge see page 6; ## For locking cartridge see page 14

## Accessories for AS-Interface Bus System

AS-I Power supply for 29,6 V DC 115/230 V AC → 29,6 V DC (85 W)	AS-I Master controller 1 Master (31 Slaves)	Software and handbook VE1ASMA1-G0000
24 V DC → 29,6 V DC (85 W)	2 Master (62 Slaves)	
115/230 VAC → 29,6 V DC (180 W)	VE1ASPS1-08519	VE1ASCT1-RS232
115/230 VAC → 29,6 V DC + 24 V DC (180 W combined)	VE1ASPS1-18109	VE1ASCT2-RS232
Installation cables for AS-Interface systems	Cable clip	AS-Interface module for external power
VE1ASCAY-YMXXX (yellow)	VE1ASAC1-CL001	M/P73202
VE1ASCAB-YMXXX (black)		
AS-Interface plug	Hand held function	Programming cable
VE1ASCN-M1200	01 020 07 0000 000 00	VE1ASPRG-PCETL

Full information (technical data, materials, dimensions etc.) please refer to relevant catalogue pages N 6.4.010  
XXX Insert cable length 25 m = 025, 50 m = 050, 100 m = 100

## Accessories for multipole connection

Hand held function	Connector cable M12 female 8 pin	Y-cable M12 female 8 pin 2 x M12 male 4 pin
01 020 07 0000 000 00	M/P73200/2 = 2 m	M/P73201 = 0,45 m
	M/P73200/5 = 5 m	
	M/P73200/10 = 10 m	



### Theoretical forces • Cushioning • Air consumption

Cylinder Ø	Theoretical forces (N) at 6 bar		Cushion length (mm)	Initial cushion volume (cm <sup>3</sup> )	Air consumption (l/cm stroke) at 6 bar	
	Outstroke	Instroke			Outstroke	Instroke
32	482	414	13	8,5	0,056	0,048
40	754	633	17	16	0,088	0,074
50	1178	990	17	25,5	0,137	0,114
63	1870	1680	22	58	0,218	0,195
80	3016	2722	22	95	0,350	0,320
100	4710	4416	30	214	0,550	0,510

### Basic dimensions

#### PRA/282000/M – Standard cylinders

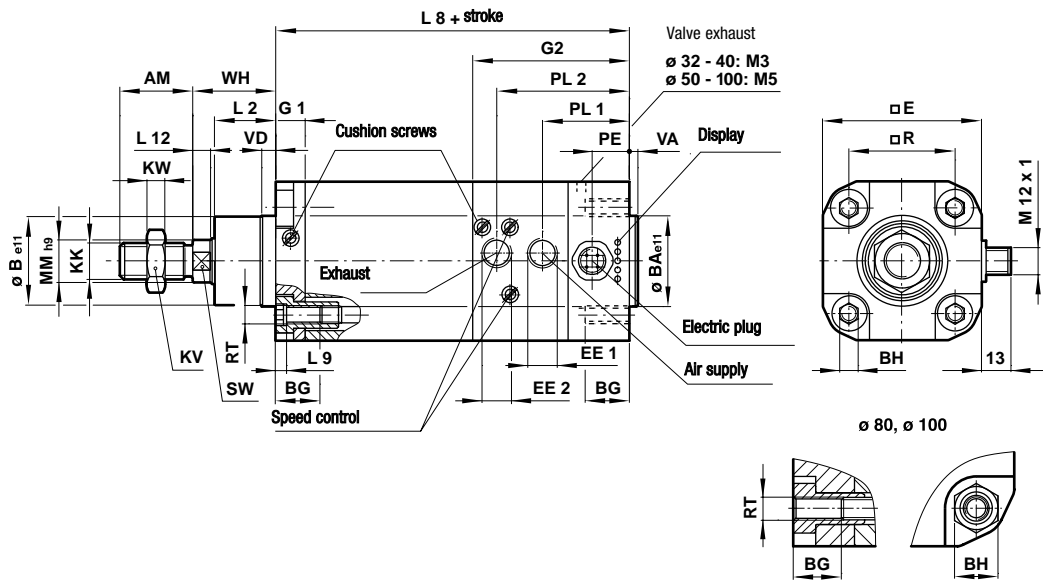

Ø	AM	Ø Be 11	Ø BAe 11	BG min.	BH (A/F)	□ E	EE 1	EE 2	G 1	G 2	KK	KV	KW	L 2
32	22	30	30	16	6	50	G 1/8	G 1/8	10,5	61	M10x1,25	17	5	20
40	24	35	35	16	6	58	G 1/4	G 1/4	12	67	M12x1,25	19	6	22
50	32	40	40	16	8	70	G 1/4	G 1/4	13	69	M16x1,5	24	8	28
63	32	45	45	16	8	85	G 3/8	G 3/8	13,5	76,5	M16x1,5	24	8	28
80	40	45	45	16	19	105	G 3/8	G 3/8	15	82	M20x1,5	30	10	33
100	40	55	55	16	19	130	G 1/2	G 3/8	19	88	M20x1,5	30	10	36

Ø	L8	L9	L12	Ø MMh9	PE	PL1	PL2	□ R	RT	SW	VA	VD	WH	kg at 0 mm	kg per 100 mm
32	94	4	5	12	16,5	36,5	53,5	32,5	M 6	10	3	6	26	0,66	0,07
40	105	4	5	16	16,5	36,5	53,5	38	M 6	13	3,5	6	30	1,03	0,11
50	106	5	6,5	20	16,5	38,5	59	46,5	M 8	17	3,5	6	37	1,58	0,18
63	121	5	6,5	20	16,5	39,5	64,5	56,5	M 8	17	4	6	37	2,42	0,19
80	128	-	10	25	16,5	39	67	72	M 10	22	4	6	46	4,12	0,29
100	138	-	10	25	16,5	43,5	73,5	89	M 10	22	4	6	51	6,34	0,35

### Wiring diagram for electric plug AS-Interface

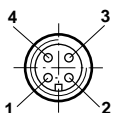

Pin 1 AS-Interface +  
 Pin 2 External power -  
 Pin 3 AS-Interface -  
 Pin 4 External power +

### Multipole

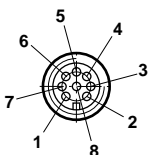

Plug Valves  
 Pin 1 Not used  
 Pin 2 Solenoid 2 (instroke)  
 Pin 3 0 V  
 Pin 4 Solenoid 1 (outstroke)

Wiring diagram for connector cable M/P73200/.

white  
 brown  
 green  
 yellow

Plug Switches

Pin 5 + 24 V dc  
 Pin 6 Switch 2 (rear end)  
 Pin 7 0 V  
 Pin 8 Switch 1 (front end)

Wiring diagram for connector cable M/P73200/.

grey  
 pink  
 blue  
 red



### PRA/282000/MG – Cylinders with piston rod bellows

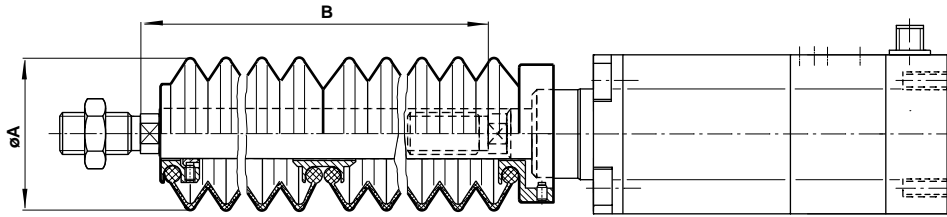

Ø	Ø A	Maximum stroke per bellow	Piston rod extension B	
			first bellow	further bellows
32	40	60	30	25
40	63	145	50	32
50	63	145	40	32
63	63	145	40	32
80	80	250	50	45
100	80	250	50	45

### PRA/282000/L4 – Cylinders with locking unit (Passive)

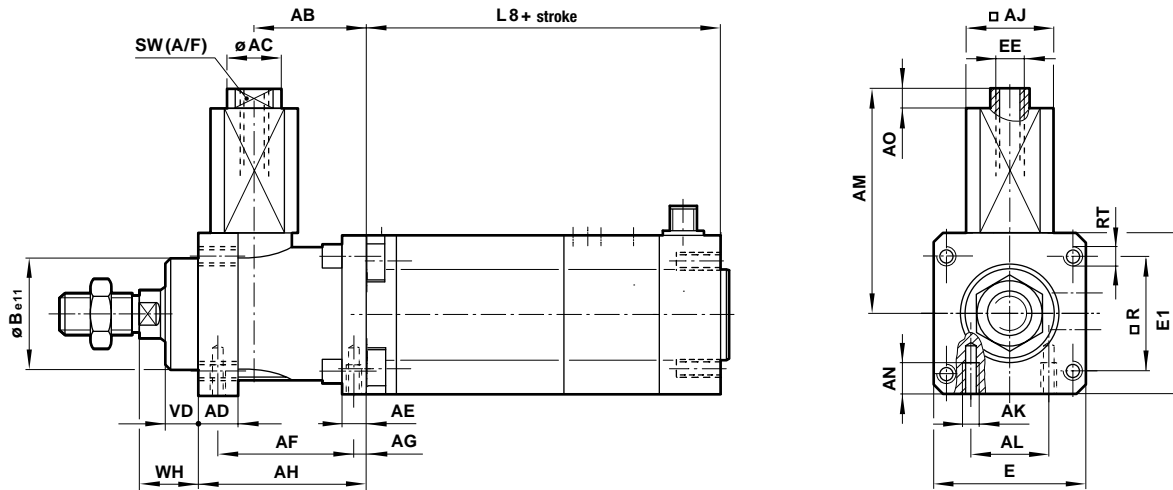

Ø	AB	Ø AC	AD	AE	AF	AG	AH	□ AJ	AK	AL	AM	AN
32	32	10	12	8	40	4,2	48	22,7	M 5	16	70,5	8
40	35,5	10	12	10	46	4,5	55	27,7	M 5	21	74,5	10
50	49	15	16	15	54	11,5	70	32,7	M 6	24	91,5	12
63	49	15	15	15	55	7,5	70	41	M 8	32	108,5	12
80	62	19	16	16	70	10	90	53	M 8	44	141,5	16
100	65	19	18	16	70	10	92	53	M 8	60	141,5	16

Ø	A0	Ø B e11	E	E 1	EE	L 8	□ R	RT	SW (A/F)	VD	WH	Forces *
32	4	30	48	50	M 5	94	32,5	M 6	8	10	16	600 N
40	4	35	56	58	M 5	105	38	M 6	8	10	18	1000 N
50	4	40	68	70	G 1/8	106	46,5	M 8	13	12	22	1500 N
63	4	45	82	85	G 1/8	121	56,5	M 8	13	12	20	2200 N
80	4	45	100	105	G 1/8	128	72	M 10	17	20	33	5000 N
100	4	55	120	130	G 1/8	138	89	M 10	17	23	38	5000 N

\* Retention forces

### Separate locking cartridge

Ø	Model	Forces *
32	QA/8032/63	600 N
40	QA/8040/63	1000 N
50	QA/8050/63	1500 N
63	QA/8063/63	2200 N
80	QA/8080/63	3000 N
80	QA/8100/63	5000 N

\* Retention forces



## Mountings

### QM/8000/35 – Front or rear stud mounting style ‘A’ (Corresponds to DIN ISO 6431, Style MX1)

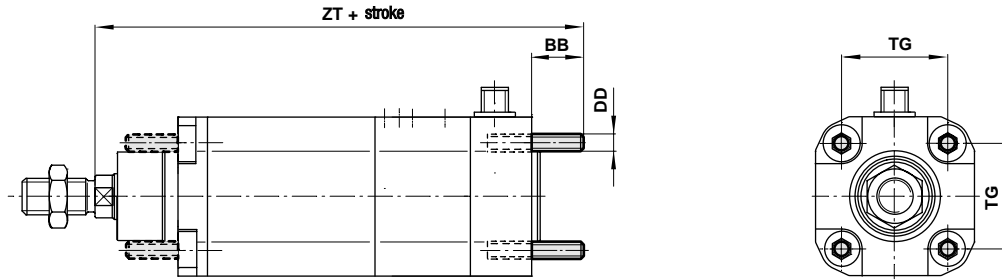

### QA/8000/22 – Rear flange mounting style ‘B’ (Corresponds to DIN ISO 6431 and VDMA 24562 Part 2, Style MF2)

### QA/8000/22 – Front flange mounting style ‘G’ (Corresponds to DIN ISO 6431 and VDMA 24562 Part 2, Style MF1)

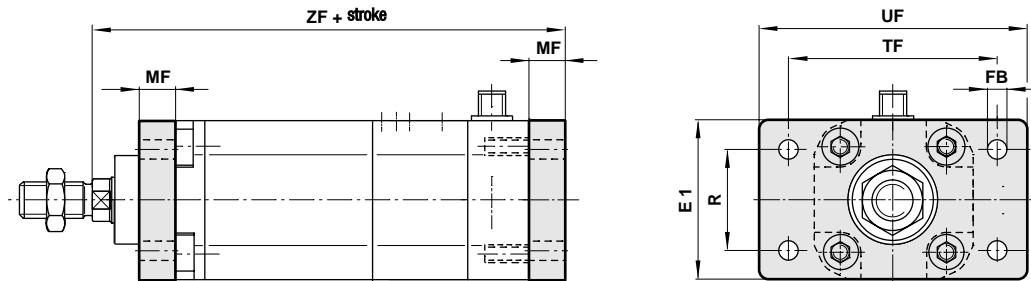

### QA/8000/21 – Foot mounting style ‘C’ (Corresponds to DIN ISO 6431 and VDMA 24562 Part 2, Style MS1)

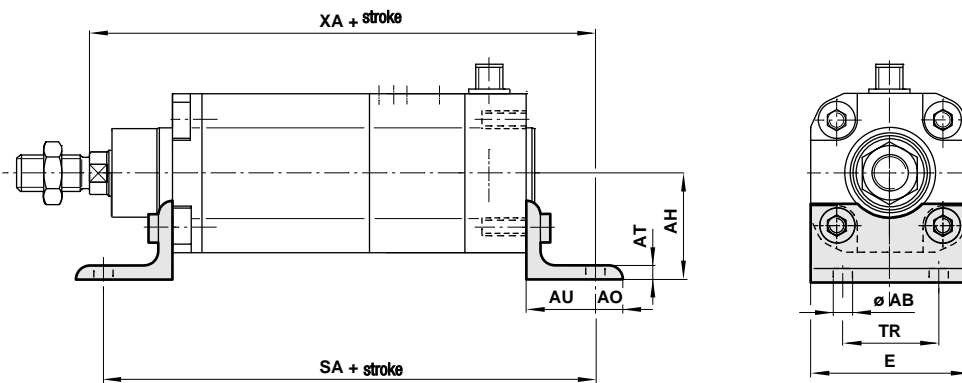

Ø	Ø AB	AH	AO	AT	AU	BB	DD	E	E1	Ø FB	MF	R	SA
32	7	32	8	4	24	17	M 6	48	50	7	10	32	142
40	9	36	9	4	28	17	M 6	53	55	9	10	36	161
50	9	45	10	5	32	23	M 8	64	65	9	12	45	170
63	9	50	12	5	32	23	M 8	74	75	9	12	50	185
80	12	63	19	5	41	28	M 10	98	100	12	16	63	210
100	14	71	19	5	41	28	M 10	115	120	14	16	75	220
Ø	TF	TG	TR	UF	W	WH	XA	ZF	ZT	'A'	'B,G'	'C'	
32	64	32,5	32	80	16	26	144	130	137	0,02 kg	0,25 kg	0,15 kg	
40	72	38	36	90	20	30	163	145	152	0,02 kg	0,35 kg	0,18 kg	
50	90	46,5	45	110	25	37	175	155	166	0,05 kg	0,70 kg	0,30 kg	
63	100	56,5	50	125	25	37	190	170	181	0,05 kg	0,80 kg	0,39 kg	
80	126	72	63	154	30	46	215	190	202	0,08 kg	1,35 kg	0,80 kg	
100	150	89	75	186	35	51	230	205	217	0,08 kg	2,20 kg	0,95 kg	



**QM/8000/25 – Piston rod clevis mounting style ‘F’**

(Corresponds to DIN ISO 8140)

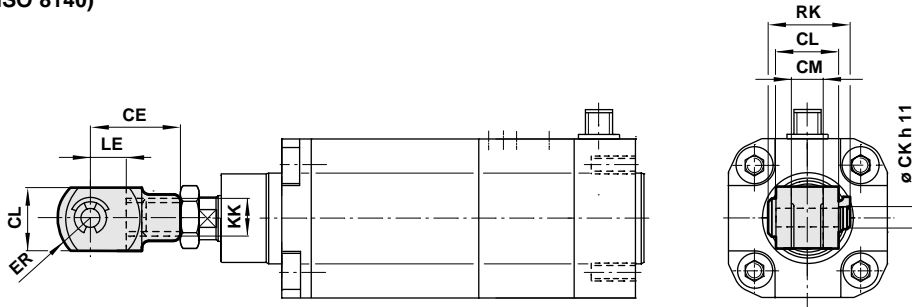

**QM/8000/26 – Front hinge mounting style ‘M’**

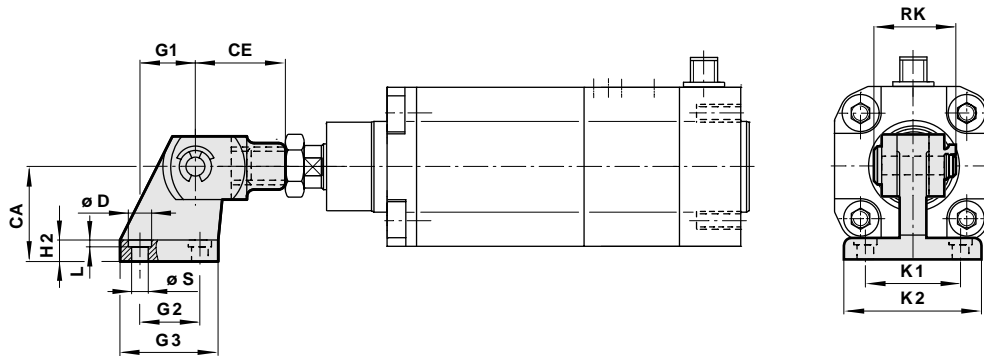

**M/P199 . . – Bracket for clevis mounting style ‘SS’**

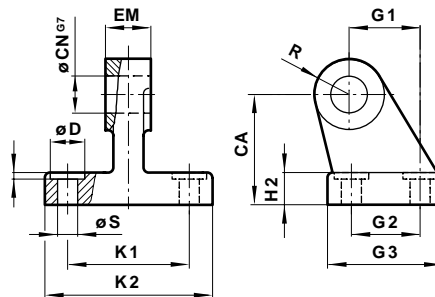

Ø	CA	CE	Ø CK h11	Ø CL	CM	Ø CN G7	Ø D	EM	ER	G 1	G 2	G 3
32	32	40	10	20	10	10	11	10	16	21	18	31
40	36	48	12	24	12	12	11	12	19	24	22	35
50	45	64	16	32	16	16	15	16	25	33	30	45
63	50	64	16	32	16	16	15	16	25	37	35	50
80	63	80	20	40	20	20	18	20	32	47	40	60
100	71	80	20	40	20	20	18	20	32	55	50	70

  

Ø	H 2	KK	K 1	K 2	L1	LE	R	RK	Ø S	‘F’	‘M’	‘SS’
32	8	M10x1,25	38	51	1,6	20	10	28	6,6	0,09 kg	0,24 kg	0,15 kg
40	10	M12x1,25	41	54	1,6	24	11	32	6,6	0,13 kg	0,33 kg	0,20 kg
50	12	M16x1,5	50	65	1,6	32	13	41,5	9	0,33 kg	0,81 kg	0,48 kg
63	12	M16x1,5	52	67	1,6	32	15	41,5	9	0,33 kg	0,83 kg	0,50 kg
80	14	M20x1,5	66	86	2,5	40	15	50	11	0,67 kg	1,42 kg	0,75 kg
100	15	M20x1,5	76	96	2,5	40	19	50	11	0,67 kg	1,87 kg	1,20 kg





**QA/8000/23 – Rear clevis mounting style ‘D’**  
 (Corresponds to DIN ISO 6431 and VDMA 24562 Part 2, Style MP2)

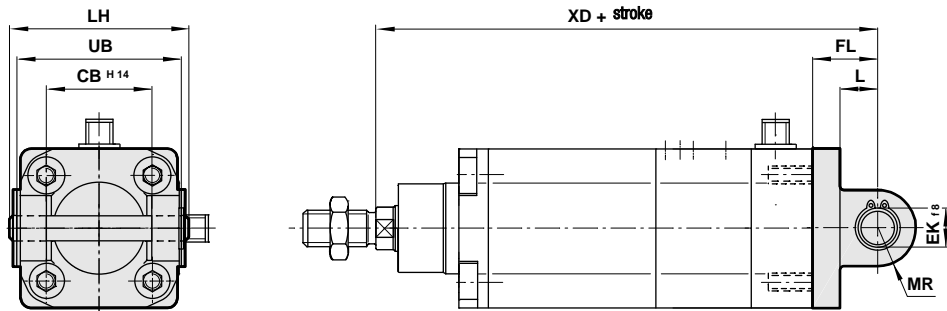

**QA/8000/24 – Rear hinge mounting style ‘L’**  
 (Corresponds to VDMA 24562 Part 2)

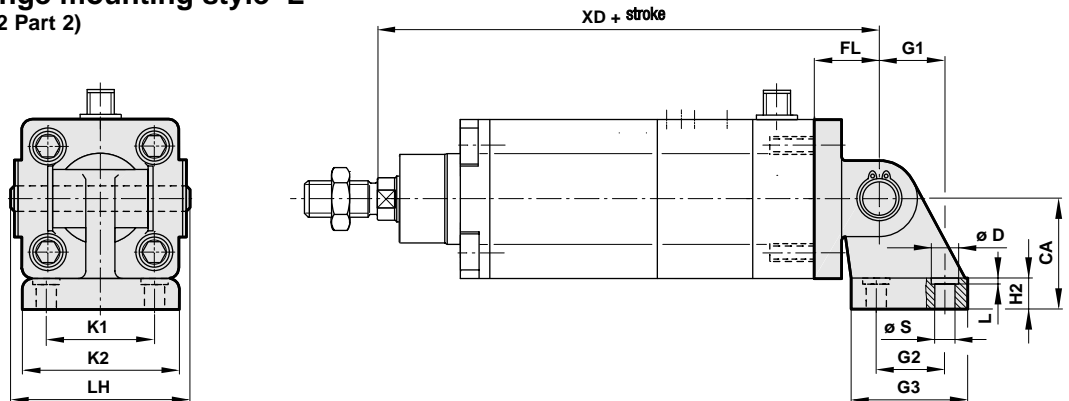

**M/P194 . . – Bracket for clevis mounting (wide clevis) style ‘SW’**  
 (Corresponds to VDMA 24562, Part 2)

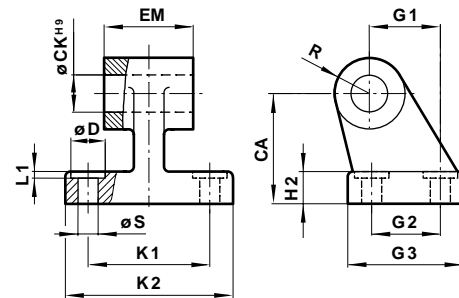

Ø	CA/CH	CB H14	Ø CK H9	Ø D	Ø EK f8	EM	FL	G 1	G 2	G 3	H 2	K 1
32	32	26	10	11	10	26	22	21	18	31	8	38
40	36	28	12	11	12	28	25	24	22	35	10	41
50	45	32	12	15	12	32	27	33	30	45	12	50
63	50	40	16	15	16	40	32	37	35	50	12	52
80	63	50	16	18	16	50	36	47	40	60	14	66
100	71	60	20	18	20	60	41	55	50	70	15	76
Ø	K 2	L	L 1	LH	MR	R	Ø S	UB	XD	‘D’	‘L’	‘SW’
32	51	1,6	1,6	52	9	10	6,6	45	142	0,11 kg	0,16 kg	0,05 kg
40	54	1,6	1,6	60	12	11	6,6	52	160	0,16 kg	0,23 kg	0,07 kg
50	65	1,6	1,6	68	12	13	9	60	170	0,22 kg	0,36 kg	0,14 kg
63	67	1,6	1,6	79	15	15	9	70	190	0,34 kg	0,52 kg	0,18 kg
80	86	2,5	2,5	99	15	15	11	90	210	0,54 kg	0,82 kg	0,28 kg
100	96	2,5	2,5	119	20	19	11	110	230	0,90 kg	1,32 kg	0,42 kg



### QA/8000/42 – Rear clevis mounting style 'D2'

(Corresponds to VDMA 24562 Part 2)

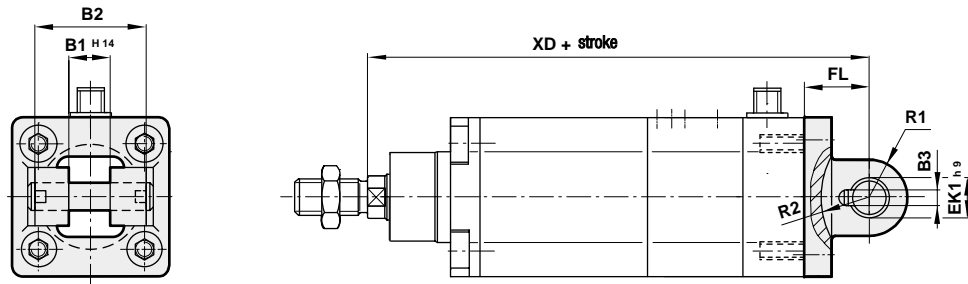

### QA/8000/43 – Universal rear hinge mounting style 'UL'

(Corresponds to VDMA 24562 Part 2)

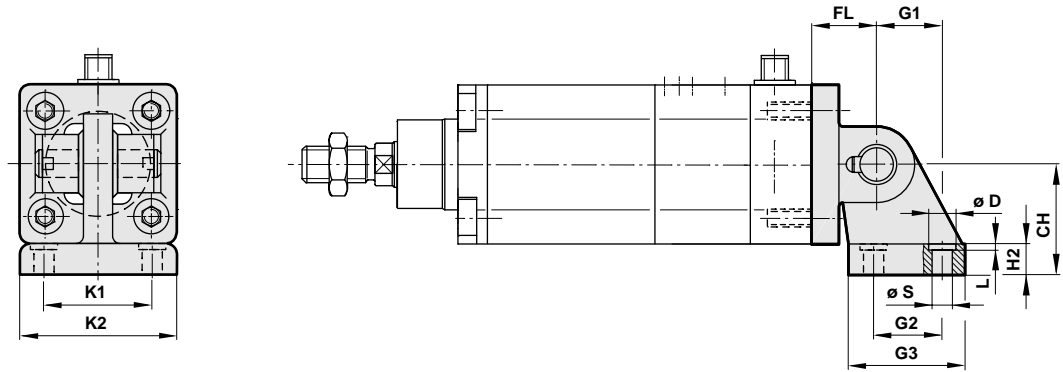

### M/P403 . . – Bracket hinge for clevis mounting style 'US'

(Corresponds to VDMA 24562 Part 2)

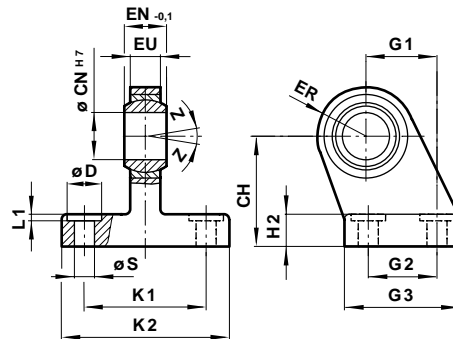

Ø	B1 H14	B2	B3	CH	Ø CN H7	Ø D	Ø EK h9	EN -0,1	ER	EU	FL	G 1	G 2
32	14	34	3,3	32	10	11	10	14	16	10,5	22	21	18
40	16	40	4,3	36	12	11	12	16	19	12	25	24	22
50	21	45	4,3	45	16	15	16	21	21	15	27	33	30
63	21	51	4,3	50	16	15	16	21	24	15	32	37	35
80	25	65	4,3	63	20	18	20	25	28	18	36	47	40
100	25	75	4,3	71	20	18	20	25	30	18	41	55	50
Ø	G 3	H 2	K1	K 2	L1	R1	R2	Ø S	XD	Z	'D2'	'UL'	'US'
32	31	8	38	51	1,6	11	17	6,6	142	13°	0,20 kg	0,39 kg	0,19 kg
40	35	10	41	54	1,6	12	20	6,6	160	13°	0,23 kg	0,47 kg	0,24 kg
50	45	12	50	65	1,6	14,5	22	9	170	13°	0,36 kg	0,82 kg	0,46 kg
63	50	12	52	67	1,6	18	25	9	190	15°	0,55 kg	1,14 kg	0,59 kg
80	60	14	66	86	2,5	22	30	11	210	15°	0,90 kg	1,93 kg	1,03 kg
100	70	15	76	96	2,5	22	32	11	230	15°	1,45 kg	2,85 kg	1,40 kg



**QA/8000/27 – Rear eye mounting style ‘R’**  
 (Corresponds to DIN ISO 6431 and VDMA 24562 Part 2, Style MP4)

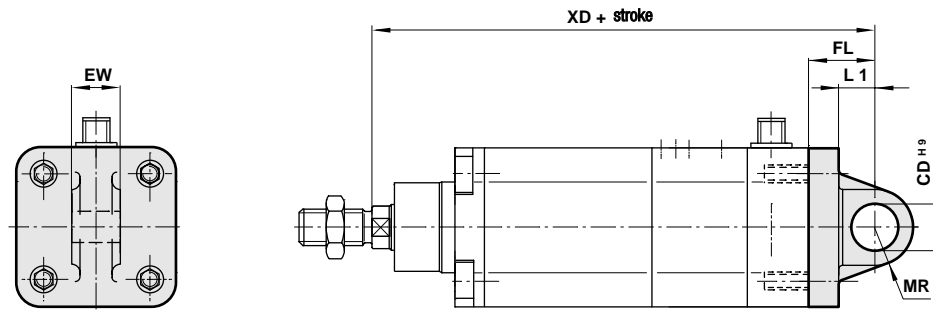

**QA/8000/33 – Universal rear eye mounting style ‘UR’**  
 (Corresponds to VDMA 24562 Part 2)

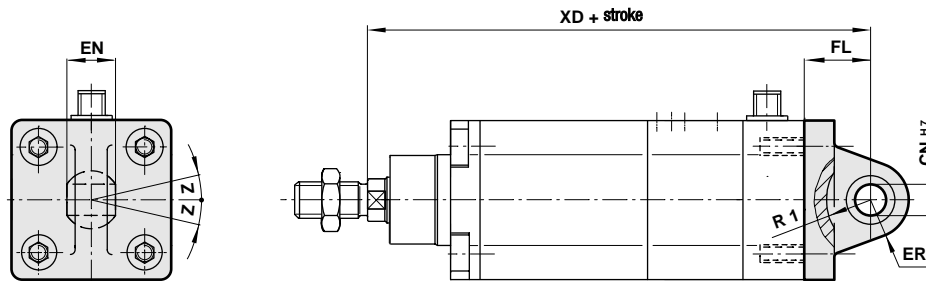

Ø	Ø CD H9	Ø CN H7	EN	ER	EW	FL	L1	MR	R	XD	Z	'R'	'UR'
32	10	10	14	16	25,8	22	13	9	14,5	142	13°	0,09 kg	0,17 kg
40	12	12	16	19	27,8	25	16	12	18	160	13°	0,11 kg	0,25 kg
50	12	16	21	21	31,7	27	17	12	19	170	13°	0,17 kg	0,40 kg
63	16	16	21	24	39,7	32	22	15	24	190	15°	0,24 kg	0,55 kg
80	16	20	25	28	49,7	36	22	15	24	210	15°	0,37 kg	0,90 kg
100	20	20	25	30	59,7	41	27	20	29	230	15°	0,59 kg	1,50 kg



### QA/8000/34 – Front or rear detachable trunnion mounting style 'FH'

(Corresponds to VDMA 24562 Part 2, Style MT 5/6)

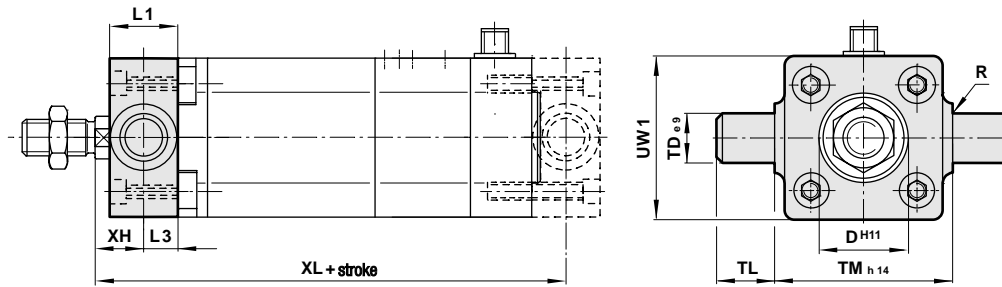

### QA/8000/41 – Swivel bearing style 'S'

For trunnion mountings style 'FH', 'UH'

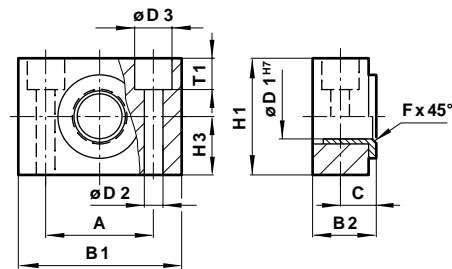

Ø	A	B 1	B 2	C	Ø D H11	Ø D 1 H7	Ø D 2	Ø D 3	F x 45°	H 1	H 3	L 1
32	32	46	18	10,5	30	12	6,6	11	1	30	15	16
40	36	55	21	12	35	16	9	15	1,6	36	18	20
50	36	55	21	12	40	16	9	15	1,6	36	18	24
63	42	65	23	13	45	20	11	18	1,6	40	20	24
80	42	65	23	13	45	20	11	18	1,6	40	20	28
100	50	75	28,5	16	55	25	14	20	2	50	25	38

Ø	L 3	R	Ø TD e9	TL	TM h14	T 1	UW 1	XH	XL	'FH'	'S'
32	8	1	12	12	50	6,8	50	18	128	0,20 kg	0,11 kg
40	10	1,6	16	16	63	9	55	20	145	0,38 kg	0,16 kg
50	12	1,6	16	16	75	9	65	25	155	0,60 kg	0,16 kg
63	12	1,6	20	20	90	11	75	25	170	1,10 kg	0,23 kg
80	14	1,6	20	20	110	11	100	32	188	1,90 kg	0,23 kg
100	19	2	25	25	132	13	120	32	208	3,50 kg	0,42 kg



**QM/8000/38 – Piston rod swivel mounting style ‘AK’**

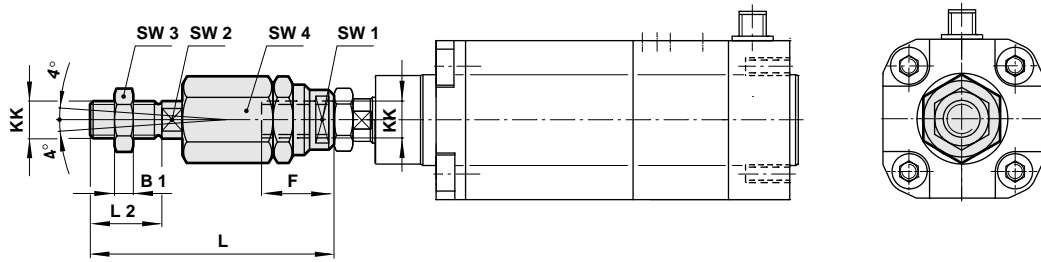

**QM/8000/32 – Universal piston rod eye mounting style ‘UF’**  
(Corresponds to DIN ISO 8139)

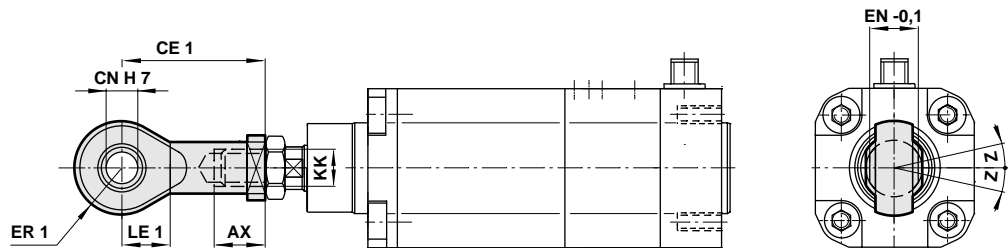

Ø	AX	B1	CE	Ø CN H7	EN -0,1	ER	F	KK	L
32	20	5	43	10	14	14	26	M 10 x 1,25	73
40	22	6	50	12	16	16	26	M 12 x 1,25	77
50	28	8	64	16	21	21	34	M 16 x 1,5	106
63	28	8	64	16	21	21	34	M 16 x 1,5	106
80	33	10	77	20	25	25	42	M 20 x 1,5	122
100	33	10	77	20	25	25	42	M 20 x 1,5	122

Ø	L 2	LE	SW 1 (A/F)	SW 2 (A/F)	SW 3 (A/F)	SW 4 (A/F)	Z	‘AK’	‘F’
32	20	15	19	12	17	30	13°	0,20 kg	0,09 kg
40	24	17	19	12	19	30	13°	0,20 kg	0,13 kg
50	32	22	30	19	24	42	15°	0,65 kg	0,33 kg
63	32	22	30	19	24	42	15°	0,65 kg	0,33 kg
80	40	26	30	19	30	42	15°	0,72 kg	0,67 kg
100	40	26	30	19	30	42	15°	0,72 kg	0,67 kg



QA/8000/61/\* – Guide blocks with roller bearings

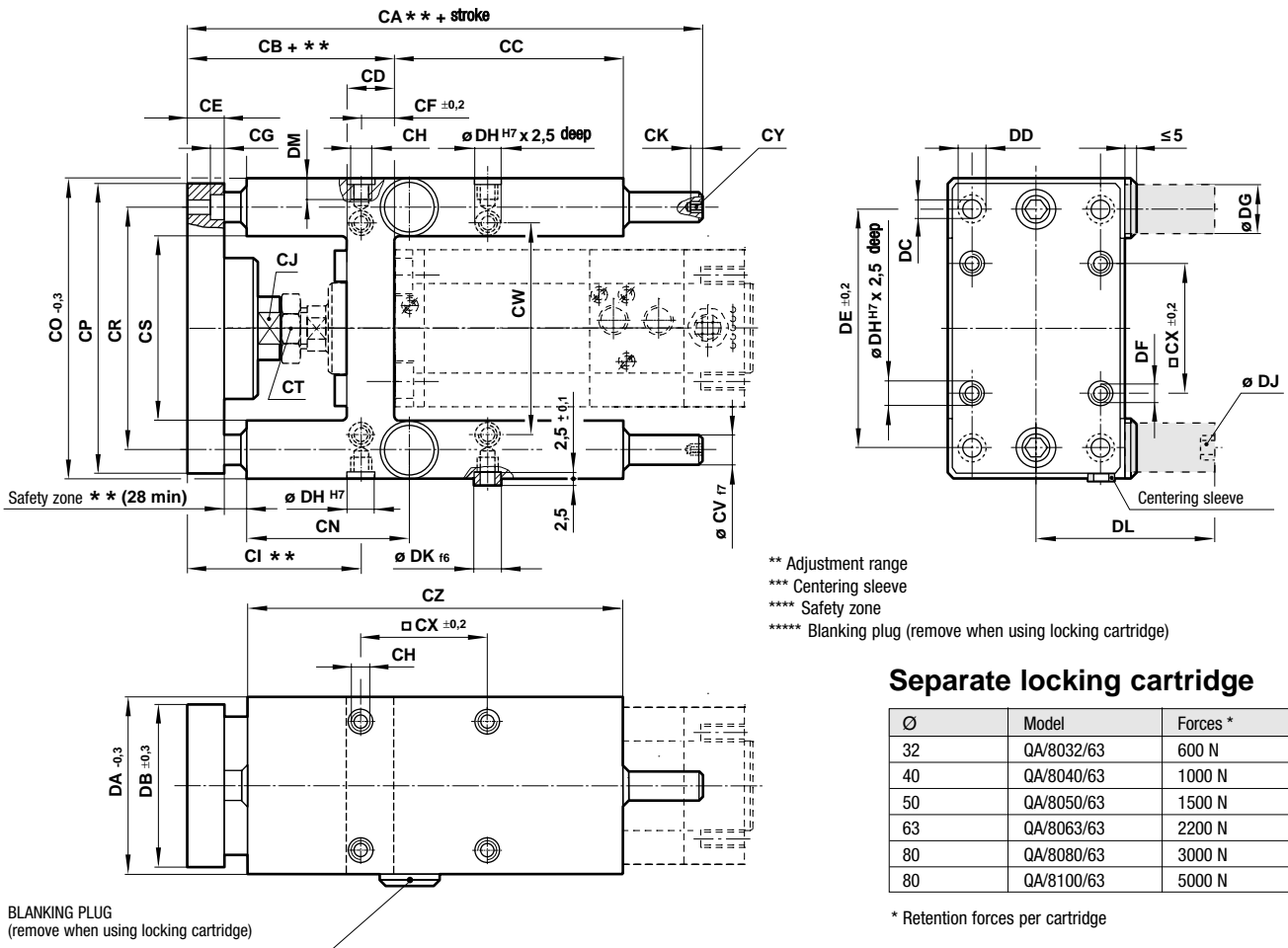

Ø	CA**	CB + **	CC	CD	CE	CF ±0,2	CG	CH	CI**	CJ (A/F)	CK	CN
32	177	100 + 5	65	28	12	15,3	6,5	M 6	84,5	13	5	61
40	192	111 + 5	69	33	12	23	6,5	M 6	88	15	6	67
50	237	128 + 10	65	40	15	33,8	9	M 8	94	22	6	75,5
63	237	128 + 10	97	40	15	29,3	9	M 8	98,5	22	6	80
80	280	151 + 10	112	50	20	37	11	M 10	114	27	7	92
100	280	156 + 10	112	55	20	40,5	11	M 10	115,5	27	7	93

Ø	CO -0,3	CP	CR	CS	CT (A/F)	ø CV f7	CW	□ CX ±0,2	CY (A/F)	CZ	DA -0,3	DB ±0,3
32	97	90	74	50,5	17	12	61	32,5	5	125	50	45
40	115	110	87	58,5	19	16	69	38	6	140	58	54
50	137	130	104	70,5	24	20	85	46,5	6	150	70	63
63	152	145	119	85,5	24	20	100	56,5	6	182	85	80
80	189	180	148	105,5	30	25	130	72	8	215	105	100
100	213	200	172	130,5	30	25	150	89	8	220	130	120

Ø	C	ø DD	DE ±0,2	DF	ø DG	ø DH H7	DJ	ø DK f6	DL	DM	at 0 mm	per 100 mm
32	6,6	11	78	M 6	22,5	9	M 5	9	70,5	14	1,20 kg	0,18 kg
40	6,6	11	84	M 6	27,5	9	G 1/8	9	74,5	14	2,20 kg	0,32 kg
50	9	15	100	M 8	32,5	11	G 1/8	11	91,5	16	3,60 kg	0,49 kg
63	9	15	105	M 8	32,5	11	G 1/8	11	91,5	16	4,60 kg	0,49 kg
80	11	18	130	M 10	54,5	13	G 1/8	13	141,5	20	8,70 kg	0,77 kg
100	11	18	150	M 10	54,5	13	G 1/8	13	141,5	20	11,0 kg	0,77 kg

\*\* Adjustment range

Note: Supplied complete with mounting screws for cylinders and two centering sleeves.



### Maximum load for QA/8000/61/\*

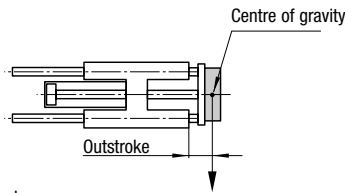

\*\* Outstroke  
\*\*\* Centre of gravity

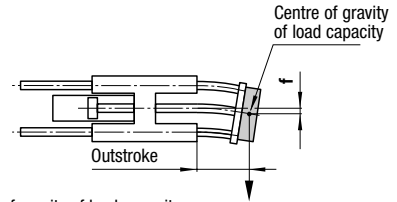

\* Centre of gravity of load capacity  
\*\* Outstroke

Maximum load capacity is dependent on the outstroke of a horizontally installed guide unit. In the case of short stroke operation, the load capacity figures taken from the diagram must be multiplied by the correction factor (diagram 2). In the curves of load capacity (diagram 1), the short stroke corrections have already been taken into account for an outstroke > 60 mm.

The total deflection of guide rods will be determined by the addition of that due to own weight (diagram 3) and that due to load capacity (diagram 4).

**Maximum load capacity depending on outstroke**  
(diagram 1)

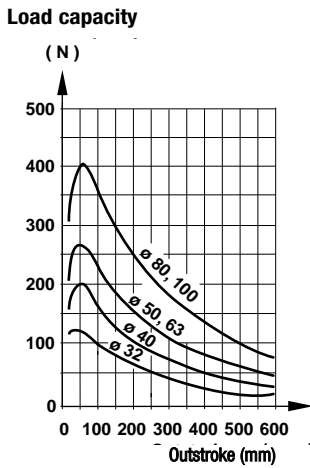

**Correction factor**  
(diagram 2)

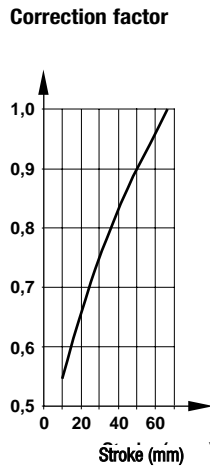

Reduction of load capacity for short-stroke operation

**Deflection caused by own weight**  
(diagram 3)

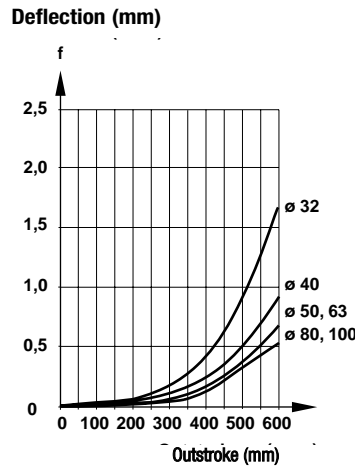

**Deflection caused by a load of 10 N**  
(diagram 4)

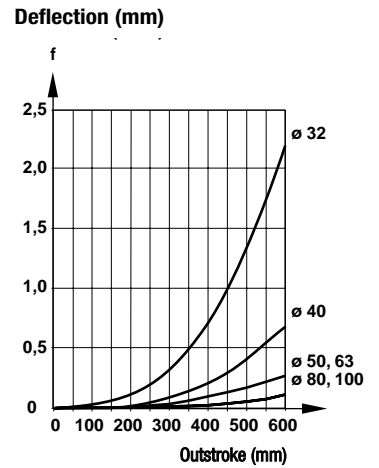

In the case of shock load applications, the figures given in the diagrams above must be reduced by a factor of 2.



## Spares kits for cylinders

Ø	Model	Spares kit
32	PRA/282032/MI	QA/282032/00
40	PRA/282040/MI	QA/282040/00
50	PRA/282050/MI	QA/282050/00
63	PRA/282063/MI	QA/282063/00
80	PRA/282080/MI	QA/282080/00
100	PRA/282100/MI	QA/282100/00

### Warning

These products are intended for use in industrial compressed air systems only. Do not use these products where pressures and temperatures can exceed those listed under '**Technical Data**'.

Before using these products with fluids other than those specified, for non-industrial applications, life-support systems, or other applications not within published specifications, consult NORGREN. Through misuse, age, or malfunction, components used in fluid power systems can fail in various modes.

The system designer is warned to consider the failure modes of all component parts used in fluid power systems and to provide adequate safeguards to prevent personal injury or damage to equipment in the event of such failure.

**System designers must provide a warning to end users in the system instructional manual if protection against a failure mode cannot be adequately provided.**

System designers and end users are cautioned to review specific warnings found in instruction sheets packed and shipped with these products.