

LINTRA® Rodless Cylinders
Non-magnetic and Magnetic Piston
Double Acting
Ø 16 to 80 mm

- **New lightweight design extrusion with integral slots for switch mounting**
- **Capable of withstanding large bending moments and lateral forces**
- **Left hand end cover incorporates alternative ports to allow both air connections to be made at one end**
- **Built-in guidance with internal and adjustable external options**

Technical Data
Medium:

Compressed air, filtered, lubricated or non-lubricated

Operation:

M/46000, M/46100, M/46200

Double acting with adjustable cushioning

M/46000/M, M/46100/M, M/46200/M

Double acting with adjustable cushioning and magnetic piston

Models:

M/46000 with internal guide

M/46100 with external adjustable guide

M/46200 with roller guided carriage

Operating Pressure:

1 to 10 bar (1,5 – 10 bar for Ø 16 mm)

Operating Temperature:

-30°C* to +80°C max.

* Consult our Technical Service for use below +2°C

Cylinder Diameters:

16, 20, 25, 32, 40, 50, 63, 80 mm

Standard Strokes:

Made to order

Maximum Strokes:

Ø 16 to 40 mm 8500 mm

Ø 50 and 63 mm 7000 mm

Ø 80 mm 5500 mm

Materials:

Ø 16 mm moulded plastic end covers and yoke

Ø 20 mm anodised aluminium end covers, moulded plastic

yoke Ø 25 to 80 mm anodised aluminium end covers and yoke

Ø 16 to 80 mm anodised aluminium carriage, special anodised extruded aluminium alloy cylinder barrel, polyurethane sealing strip and piston seals, polyamide cover strip, nitrile rubber seals

Ordering Examples

See page N 1.6.002.03

Mountings and Switches

See page N 1.6.002.03

Alternative Models

Heavy duty cylinders N 1.6.015.01

Accessories

Shock absorbers
for Ø 25 to 63 mm

See page

N 1.11.011.01

Shock absorbers
for Ø 80 mm

N 1.11.031.01

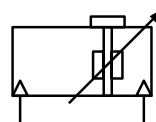

Non-magnetic piston

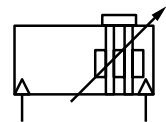

Magnetic piston

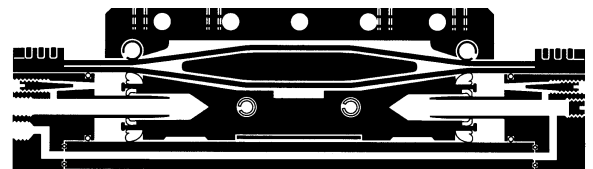



Alternative Cylinders

Symbol	Model (non-magnetic piston)	Symbol	Model (magnetic piston)	Description	Dimensions page
	M/46000		M/46000/M	With internal guiding system (∅ 16 to 80 mm)	6
	M/46100		M/46100/M	With external guiding system (∅ 16 to 80 mm)	7
	M/46200		M/46200/M	With roller guiding system (∅ 25 to 63 mm)	8
	M/46000/IC M/46100/IC M/46200/IC		M/46000/MC M/46100/MC M/46200/MC	With alternative ports (∅ 25 to 63 mm)	9
	M/46100/ID M/46200/ID		M/46100/MD M/46200/MD	With double carriages	8
	M/46000/L1		M/46000/L3	Active holding brake for ∅ 25 to 63 mm. Applying pressure activates the brake. The brake lining is pushed against a stainless steel strip. To release, depressurize. Operating Pressure: 2 to 10 bar	10
	M/46000/L2		M/46000/L4	Passive holding brake for ∅ 25 to 63 mm. Applying pressure releases the brake. When the pressure is released the brake lining is pushed against the stainless steel strip by a spring loaded plate. Operating Pressure: 5 to 10 bar	10
	EQM/46000 EQM/46100 EQM/46200		EQM/46000/M EQM/46100/M EQM/46200/M	With valve adaptors (∅ 25 to 63 mm)	9

Model Codes

** M/46 ** ** / ** / ** ** *

Variants	Substitute
Valve adaptors	EQ

Guiding system	Substitute
Internal	0
External	1
Roller	2

Cylinder Diameters (mm)	Substitute
16	16
20	20
25	25
32	32
40	40
50	50
63	63
80	80

Strokes (mm)
Made to order

Variants (non-magnetic piston)	Substitute
Alternative ports	IC
Active brake	L1
Passive brake	L2
Double carriages	ID
M/46*/ID/.../****	Distance between carriage centres (mm)

Variants (magnetic piston)	Substitute
Alternative ports	MC
Active brake	L3
Passive brake	L4
Double carriages	MD
M/46*/MD/.../****	Distance between carriage centres (mm)

Note: Disregard option positions not used.
For combinations of cylinder variants please consult our Technical Service.

Warning

These products are intended for use in industrial compressed air systems only. Do not use these products where pressures and temperatures can exceed those listed under 'Technical Data'.

Before using these products with fluids other than those specified, for non-industrial applications, life-support systems, or other applications not within published specifications, consult NORGRN.

Through misuse, age, or malfunction, components used in fluid power systems can fail in various modes.



The system designer is warned to consider the failure modes of all component parts used in fluid power systems and to provide adequate safeguards to prevent personal injury or damage to equipment in the event of such failure.

System designers must provide a warning to end users in the system instructional manual if protection against a failure mode cannot be adequately provided.

System designers and end users are cautioned to review specific warnings found in instruction sheets packed and shipped with these products.



Switches

	Cable	Plug (M8x1)
Model		
Reed	M/50/LSU/.. M/50/RAC/5V	M/50/LSU/CP —
Solid state	M/50/EAP/.. M/50/EAN/..	M/50/EAP/CP M/50/EAN/CP

Reed	Model	Voltage V a.c.	V d.c.	Current Max.	Temperature °C	LED	Features	Cable/Plug	Cable Type	Plug-in Cable Straight	90°	Catalogue Page
	M/50/LSU/*V	10 to 240	10 to 170	180 mA	-20° to +80°	●	—	2, 5, 10 m	PVC 2 x 0,25	—	—	N 4.3.005
	M/50/LSU/5U	10 to 240	10 to 170	180 mA	-20° to +80°	●	—	5 m	PUR 2 x 0,25	—	—	N 4.3.005
	M/50/RAC/5V	10 to 240	10 to 170	180 mA	-20° to +80°	—	Changeover	5 m	PVC 3 x 0,25	—	—	N 4.3.005
	M/50/LSU/CP	10 to 60	10 to 75	180 mA	-20° to +80°	●	—	Plug M8x1	—	M/P73001/5	—	N 4.3.005
	M/50/EAP/*V	—	10 to 30	150 mA	-20° to +80°	●	PNP	2, 5, 10 m	PVC 3 x 0,25	—	—	N 4.3.007
	M/50/EAP/CP	—	10 to 30	150 mA	-20° to +80°	●	PNP	Plug M8x1	—	M/P73001/5	—	N 4.3.007
	M/50/EAN/*V	—	10 to 30	150 mA	-20° to +80°	●	NPN	2, 5, 10 m	PVC 3 x 0,25	—	—	N 4.3.007
	M/50/EAN/CP	—	10 to 30	150 mA	-20° to +80°	●	NPN	Plug M8x1	—	M/P73001/5	—	N 4.3.007

* Insert cable length

Full information on switches (technical data, cable materials, dimensions etc.) please refer to relevant catalogue pages

Mountings and Accessories

Ø mm	Style 'C'	Style 'S'	Style 'UV'	Style 'UW'	Style 'V'	Style 'W'	Assembly kit for shock absorbers	Plate for shock absorbers	Groove Cover	Groove Key
										
	Page 12	Page 13	Page 12	Page 13	Page 12	Page 13	Page 14	Page 14	Page 15	Page 15
16	QM/46016/21	QM/46016/37	QM/46016/34	—	QM/46016/32	QM/46116/35	—	—	M/K72725/1000	M/P72816
20	QM/46020/21	QM/46020/37	QM/46020/34	QM/46120/36	QM/46020/32	QM/46120/35	—	—	M/K72725/1000	M/P72816
25	QM/46025/21	QM/46025/37	QM/46025/34	QM/46125/36	QM/46025/32	QM/46125/35	QM/46125/67	—	M/K72725/1000	M/P72816
32	QM/46032/21	QM/46032/37	QM/46032/34	QM/46132/36	QM/46032/32	QM/46132/35	QM/46132/67	—	M/K72725/1000	M/P72816
40	QM/46040/21	QM/46040/37	QM/46040/34	QM/46140/36	QM/46040/32	QM/46140/35	QM/46140/67	M/P41434	M/K72725/1000	M/P72816
50	QM/46050/21	QM/46050/37	QM/46050/34	QM/46150/36	QM/46050/32	QM/46150/35	QM/46150/67	M/P41435	M/K72725/1000	M/P72816
63	QM/46063/21	QM/46063/37	QM/46063/34	QM/46163/36	QM/46063/32	QM/46163/35	QM/46163/67	M/P41436	M/K72725/1000	M/P72816
80	QM/46080/21	QM/46080/37	QM/46080/34	—	QM/46080/32	QM/46180/35	—	—	M/K72725/1000	M/P72816

Ordering Examples

Cylinders

To order an internally guided cylinder 40 mm bore with a 6000 mm stroke

quote: **M/46040/6000**

To order an externally guided cylinder 50 mm bore with a 7000 mm stroke

quote: **M/46150/7000**

Mountings

To order a foot flange mounting style 'C' for 80 mm bore cylinder

quote: **QM/46080/21**

Switches

To order a reed switch with LED and 2 m cable length

quote: **M/50/LSU/2V**

Theoretical Forces • Cushion Lengths • Holding Forces

Ø mm	Theoretical forces (N) at 6 bar		Air consumption (l/cm) per stroke at 6 bar	Cushion length (mm)	Holding forces (N) of the brake (on dry braking surface)	
	ACTIVE (L1 + L3) at 6 bar	PASSIVE (L2 + L4)			ACTIVE (L1 + L3) at 6 bar	PASSIVE (L2 + L4)
16	120	188	0,014	12	-	-
20	188	294	0,022	26	-	-
25	294	482	0,035	26	500	220
32	482	754	0,056	35	900	375
40	754	1178	0,088	50	1500	630
50	1178	1870	0,137	60	2500	1000
63	1870	3016	0,218	70	4000	1650
80	3016	-	0,350	75	-	-

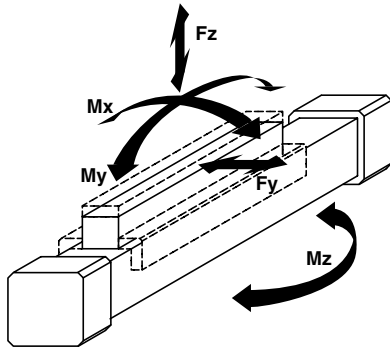

Loading values for LINTRA® cylinders

The values given in the table below show the single forces in the directions Fy and Fz and the maximum moments Mx, My and Mz. All values are applicable only for speeds of max. 0,2 m/s. A requirement for using these values is a constant movement (no jerking) of the mass over the whole stroke length of the cylinder. The reference point from which the moments for all cylinders should be calculated is the centreline of the piston.

For speeds up to 2 m/s please use our calculation programme PNEUCALC. It is available upon request. PNEUCALC is suitable for all PC's having MS Windows 95 and higher.

Total loads

When a LINTRA® cylinder has to take several loads and moments, an additional calculation is necessary using this formula:

$$\frac{Mx}{Mx \text{ max}} + \frac{My}{My \text{ max}} + \frac{Mz}{Mz \text{ max}} + \frac{Fy}{Fy \text{ max}} + \frac{Fz}{Fz \text{ max}} \leq 1$$

Ø mm	Internal guide, M/46000					External guide, M/46100			Roller guide, M/46200			
	Fy (N)	Fz (N)	Mx (Nm)	My (Nm)	Mz (Nm)	Fy, Fz (N)	Mx (Nm)	My, Mz (Nm)	Fy (N)	Fz (N)	Mx (Nm)	My, Mz (Nm)
16	40	120	0,3	3,8	1,1	200	2	5,5	-	-	-	-
20	90	280	0,9	12	3,6	470	6	18	-	-	-	-
25	110	350	1,3	19	5,6	590	9	28	590	1180	13	42
32	150	460	2,5	30	8,6	780	17	43	780	1560	25	64
40	300	900	5,8	77	22	1500	39	110	1500	3000	58	160
50	400	1200	9,8	110	32	2000	65	160	2000	4000	97	240
63	640	1900	18	240	70	3200	120	350	3200	6400	180	520
80	780	2300	27	360	100	3900	180	520	-	-	-	-

Loading values applicable to a speed of ≤ 0,2 m/s. Maximum working life is normally reached below a speed of 1 m/s.

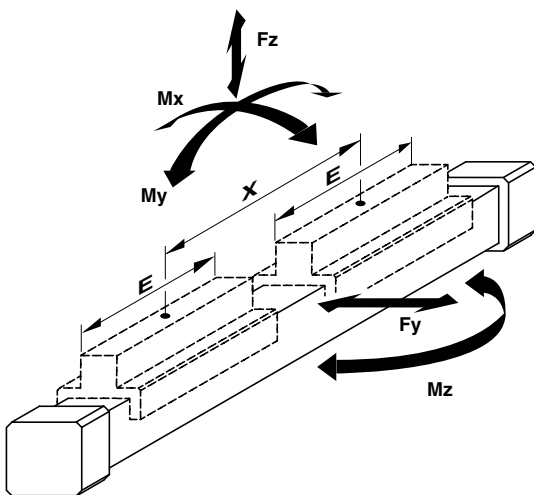

Loading values for LINTRA® cylinders with externally guided secondary carriage

The values given in the table below show the single forces in the directions Fy and Fz and the maximum moments Mx, My and Mz. All values are applicable only for speeds of max. 0,2 m/s. A requirement for using these values is a constant movement (no jerking) of the mass over the whole stroke length of the cylinder. The reference point from which the moments for all cylinders should be calculated is the centreline of the pistons.

For speeds up to 2 m/s please use our calculation programme PNEUCALC. It is available upon request. PNEUCALC is suitable for all PC's having MS Windows 95 and higher.

Total loads

When a LINTRA® cylinder has to take several loads and moments, an additional calculation is necessary using this formula:

$$\frac{Mx}{Mx \text{ max}} + \frac{My}{My \text{ max}} + \frac{Mz}{Mz \text{ max}} + \frac{Fy}{Fy \text{ max}} + \frac{Fz}{Fz \text{ max}} \leq 1$$

Ø mm	External guide, M/46100/ID and M/46100/MD; Roller guided M/46200/ID and M/46200/MD											
	Fy, Fz (N)	Mx (Nm)	My, Mz (Nm) x min.=E	x=100 mm	x=150 mm	x=200 mm	x=250 mm	x=300 mm	x=350 mm	x=400 mm	x=450 mm	x=500 mm
16	400	4	14	17	23	29	35	41	48	54	60	66
20	940	12	64	-	80	99	119	139	158	178	197	217
25	1180	18	96	-	106	131	155	180	205	230	255	279
32	1560	34	155	-	-	181	213	246	278	310	343	375
40	3000	78	393	-	-	-	435	496	557	618	679	740
50	4000	130	457	-	-	-	457	518	579	639	700	761
63	6400	240	1280	-	-	-	-	-	1360	1500	1630	1770
80	7800	360	1910	-	-	-	-	-	-	1940	2110	2270

Loading values applicable to a speed of ≤ 0,2 m/s. Maximum working life is normally reached below a speed of 1 m/s.



Cushioning Performance

The dynamic energy of a LINTRA® cylinder is caused by direct or partial external loads which must be absorbed by pneumatic cushioning. The cushioning ability depends to a large extent on the pneumatic circuit (e. g. counter pressure, pre-exhaust). The values given in the diagram were tested with an operation pressure of 6 bar using a 5/2 control valve. When installed horizontally, depending upon the speed, dynamic energy can be absorbed by the cylinder. Whenever the values given in the diagram are exceeded, the transported mass must be cushioned by additional shock absorbers. These have to be located at the center of gravity of the mass.

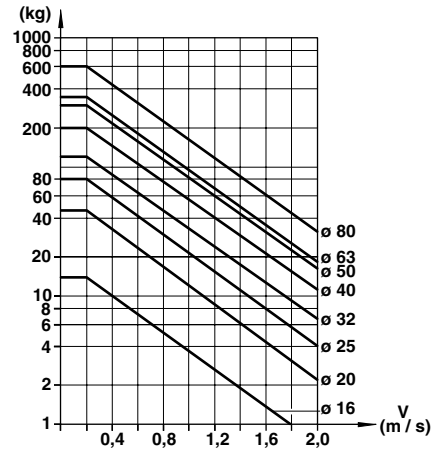

Cylinder Deflection

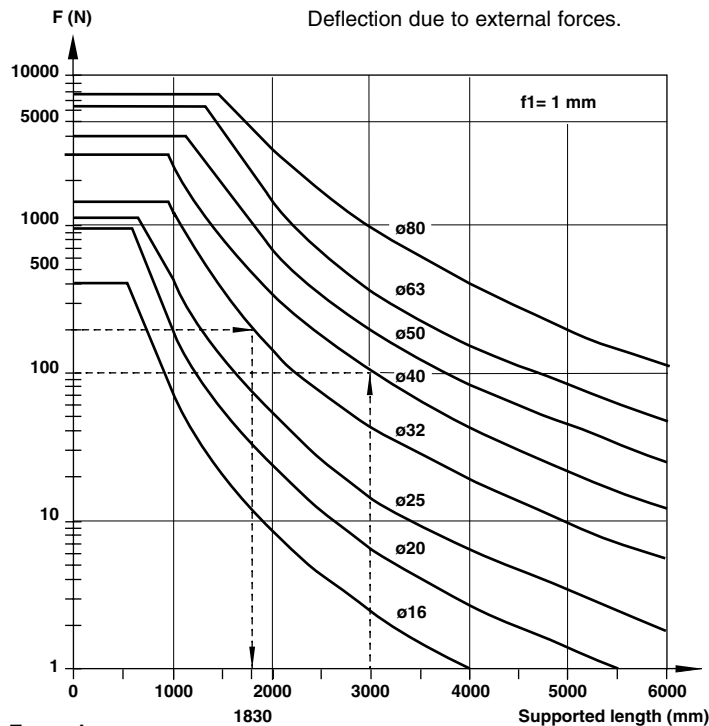

Example:
Cylinder Ø 32 mm, stroke length 3500 mm, external load 200 N
Maximum distance between supports = 1830 mm (see diagramme).
Therefore an additional support is required.

Deflection due to cylinder weight.

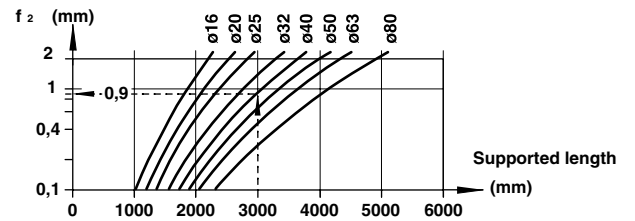

Example:

Cylinder Ø 40 mm, external force 180 N, distance between supports 3000 mm
Required: Total deflection
1. Deflection due to external force:
See diagram → $(1\text{ mm}/100\text{ N}) \cdot 180\text{ N}$ **1,8 mm**
2. Deflection due to cylinder weight: See diagramme → **+ 0,9 mm**
Total deflection: **2,7 mm**

Maximum permitted deflection $(f_1 + f_2) < 1\text{ mm per } 1000\text{ mm stroke}$

A deflection of more than 3 mm is not permitted.

Maximum load right angle mounting system

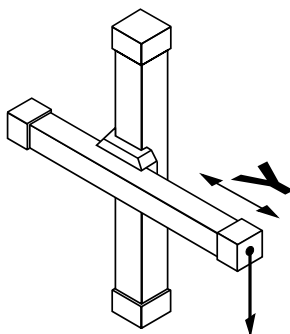

Externally guided

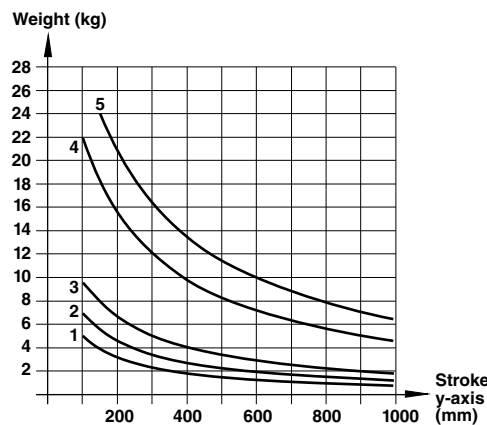

Roller guided

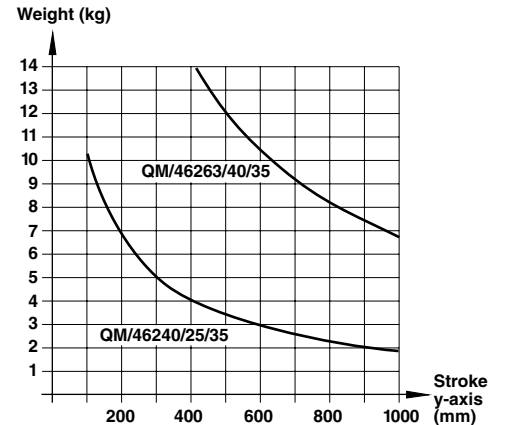

1	QM/46125/20/33	4	QM/46140/40/33 · QM/46163/40/33
2	QM/46125/25/33 · QM/46132/25/33 · QM/46140/25/33	5	QM/46150/50/33
3	QM/46132/32/33 · QM/46140/32/33 · QM/46150/32/33		

Loading values applicable to a speed of $\leq 0,2\text{ m/s}$.



Basic Dimensions M/46000 – Cylinders with Internal Guide

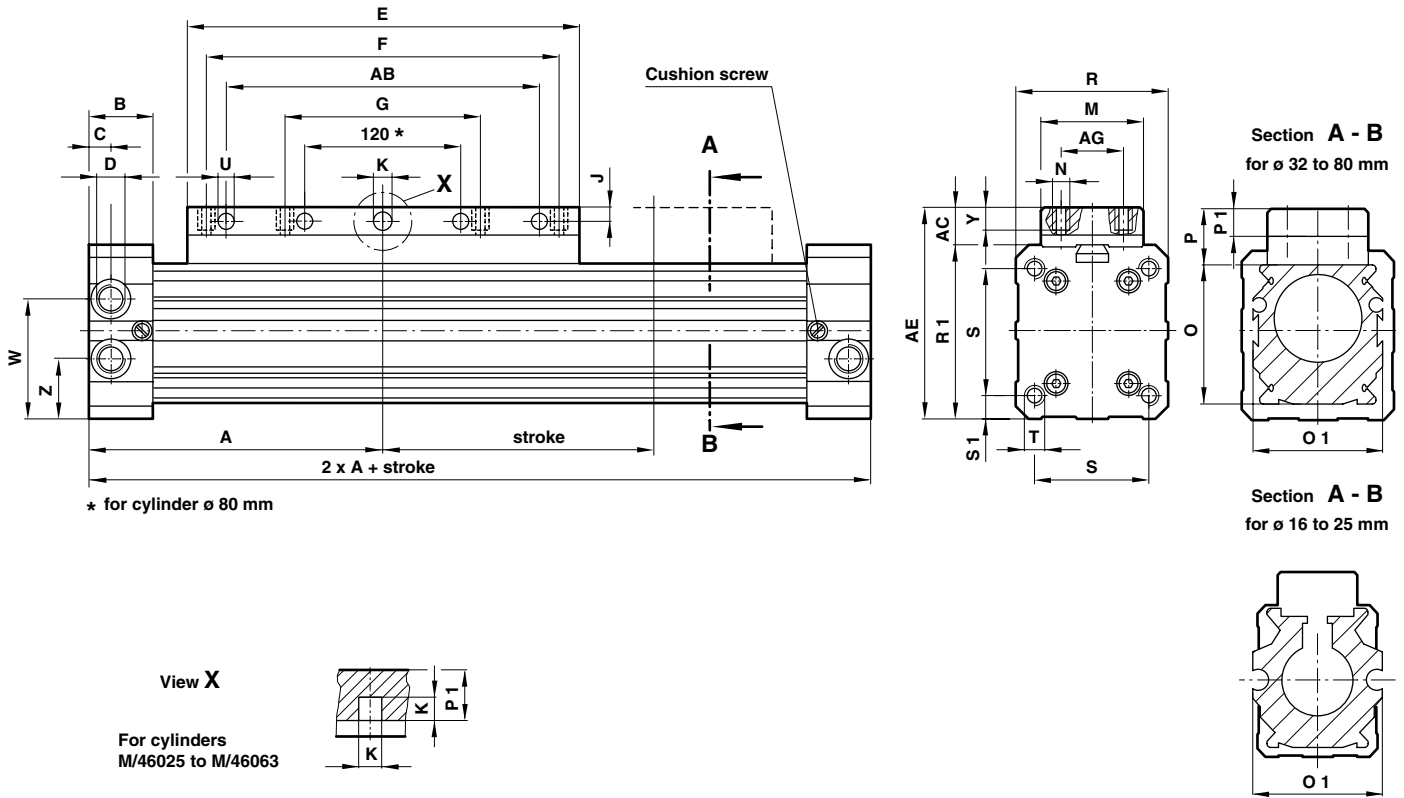

\varnothing	A	AB	AC	AE	AG	B	C	D	E	F	G	J	K	M	N
16	62,5	-	7	38	8	17,5	8	M5	80	60	-	2,5	\varnothing 3 ^{D7}	18	M3
20	85	-	14	54	18	23	8	G1/8	110	80	40	3,5	\varnothing 4,2 ^{D7}	27	M5
25	100	-	12	60	20	23	14,5	G1/8	130	90	45	-	\square 4,5	32	M5
32	120	-	16	76	25	27	10,5	G1/4	160	120	60	-	\square 6	45	M5
40	150	-	15	90	25	30	11,5	G1/4	215	160	80	-	\square 6	45	M6
50	180	-	20	110	25	35	14	G3/8	250	190	95	-	\square 8	50	M8
63	215	-	20	125	25	40	17	G1/2	320	240	120	-	\square 8	50	M8
80	260	240	24	154	25	45	17	G1/2	390	300	150	9	\varnothing 12 ^{E7}	50	M10
\varnothing	O	O 1	P	P 1	R	R 1	S	S 1	T	\varnothing U	W	Y	Z	at 0 mm	per 100 mm
16	25	26	12	-	27	31	16	5,5	M3-5#	-	-	4	16,5	0,16 kg	0,10 kg
20	32	32	18,5	-	40	40	32	4	M5-12#	-	-	12	21,5	0,50 kg	0,15 kg
25	40	40	16	7,5	48	48	37	5,5	M5-13#	-	33	7	17	0,80 kg	0,20 kg
32	52	52	20	10	60	60	47	6,5	M6-17#	-	40	8	20	1,60 kg	0,35 kg
40	65	65	20	10	75	75	58	8,5	M8-20#	-	50	8	25	2,70 kg	0,50 kg
50	80	80	25	13	90	90	70	10	M8-18#	-	60	11	30	4,80 kg	0,75 kg
63	95	95	25	14	105	105	84	10,5	M10-24#	-	70	11	35	7,20 kg	1,00 kg
80	120	120	29	-	130	130	100	15	M12-26#	11	90	15	40	13,20 kg	1,50 kg

deep



M/46100 – Cylinders with External Guide

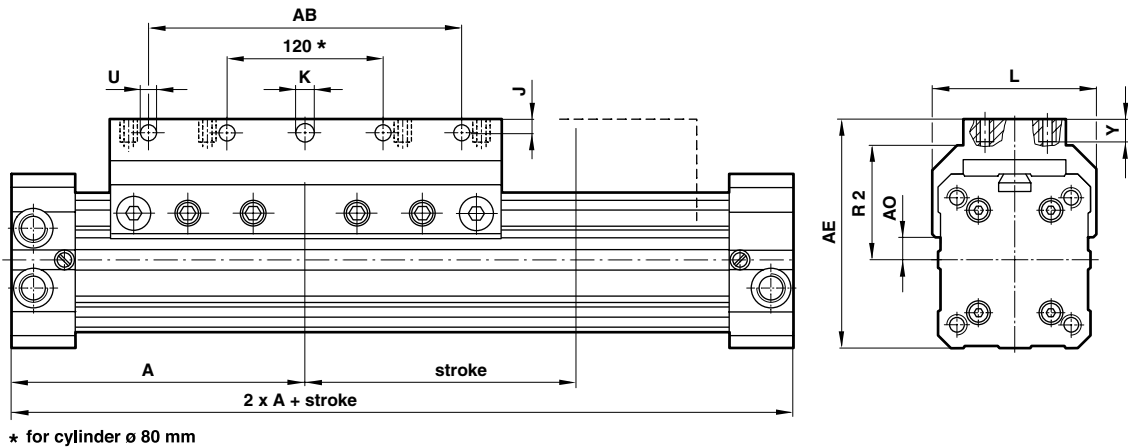

For full dimensions see page N 1.6.002.06

∅	A	AB	AE	AO	J	K	L	R 2	∅ U	Y	at 0 mm	per 100 mm
16	62,5	–	38	7,5	–	–	31	18,5	–	5	0,18 kg	0,10 kg
20	85	60	59	6,5	7,5	∅ 5,5	42	24	5,5	12	0,60 kg	0,15 kg
25	100	70	67,5	9,5	5	∅ 5,5	52	34	5,5	12	0,90 kg	0,20 kg
32	120	90	82	15,5	5	∅ 5,5	64	42,5	5,5	12	1,70 kg	0,35 kg
40	150	120	97,5	16,5	5	∅ 6,6	79	49,5	6,6	12	2,90 kg	0,50 kg
50	180	160	117	24	6,5	∅ 9	92	58,5	9	17	4,90 kg	0,75 kg
63	215	190	137	25,5	7,5	∅ 9	110	68	9	20	7,70 kg	1,00 kg
80	260	240	165	38	10	∅ 12 ^{E7}	130	81	11	25	13,40 kg	1,50 kg

To order a cylinder with external guided carriage, ∅ 32 mm and 800 mm stroke
Quote: M/46132/800

M/46100/ID and .../MD – Cylinders with Double Carriages

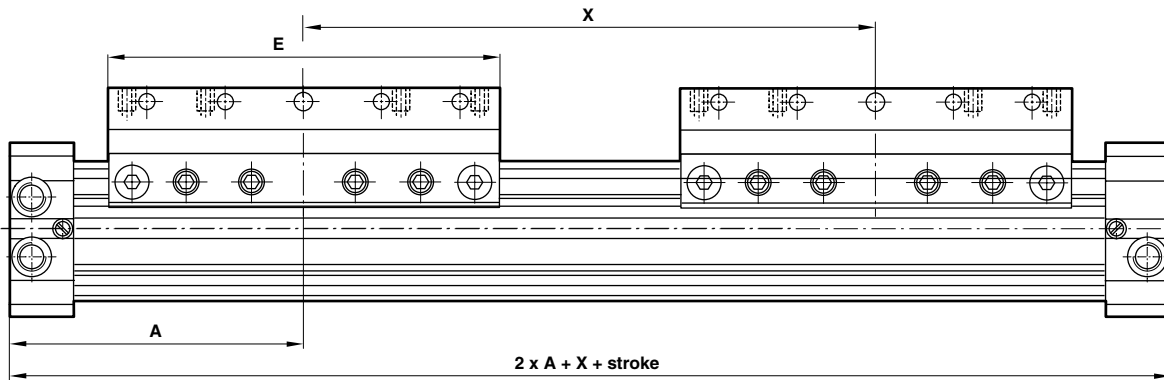

For full dimensions see page N 1.6.002.06

∅	A	E	X min.	X max.	at 0 mm	per 100 mm
25	100	130	130	500	2,60 kg	0,20 kg
32	120	160	160	500	4,60 kg	0,35 kg
40	150	215	215	500	7,60 kg	0,50 kg
50	180	250	250	500	13,40 kg	0,75 kg
63	215	320	320	500	20,60 kg	1,00 kg



M/46200 – Cylinders with Roller Guided Carriage

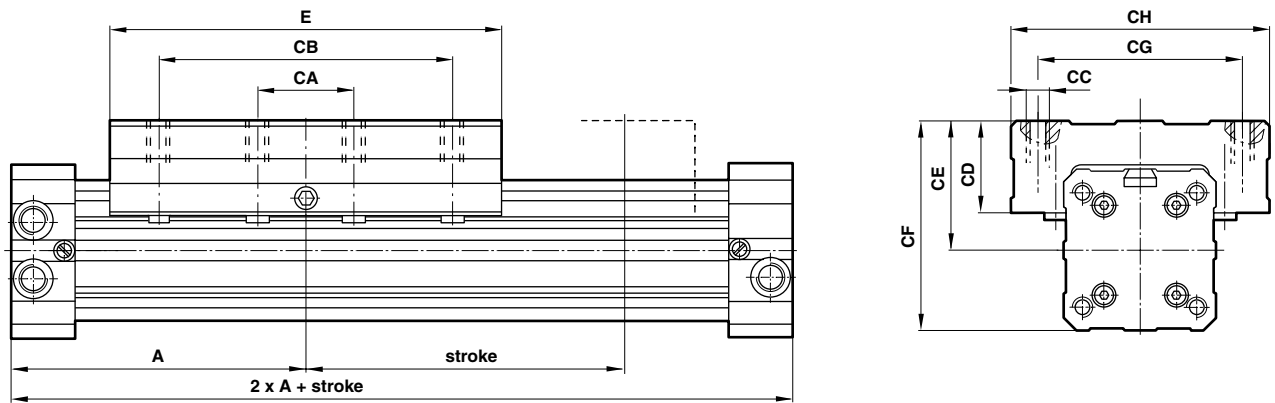

For full dimensions see page N 1.6.002.06

∅	A	CA	CB	CC	CD	CE	CF	CG	CH	E	at 0 mm	per 100 mm
25	100	45	90	M6-14 deep	36	42	66	60	85	150	1,70 kg	0,20 kg
32	120	60	120	M8-16 deep	38	50	80	75	98	180	3,10 kg	0,35 kg
40	150	80	150	M8-16 deep	42	57,5	95	92	118	215	5,00 kg	0,50 kg
50	180	90	180	M10-20 deep	44	67	112	100	132	250	9,10 kg	0,75 kg
63	215	120	240	M10-20 deep	47	74,5	127	110	140	320	13,90 kg	1,00 kg

M/46200ID and .../MD – Cylinders with Double Carriage

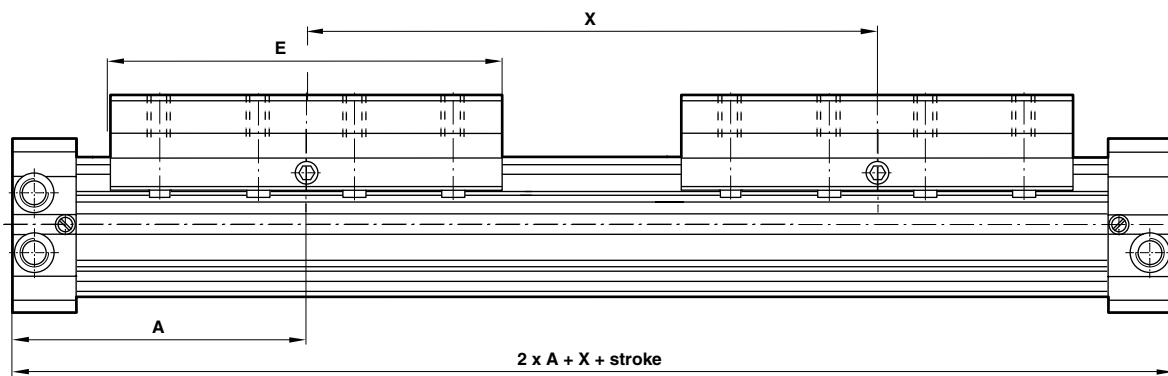

∅	A	E	X min.	X max.	at 0 mm	per 100 mm
16	62,5	80	80	500	0,20 kg	0,10 kg
20	85	110	110	500	0,80 kg	0,15 kg
25	100	130	130	500	1,20 kg	0,20 kg
32	120	160	160	500	2,20 kg	0,35 kg
40	150	215	215	500	3,60 kg	0,50 kg
50	180	250	250	500	6,00 kg	0,75 kg
63	215	320	320	500	9,60 kg	1,00 kg
80	260	390	390	500	15,90 kg	1,50 kg



M/46000/IC, .../MC; M/46100/IC, .../MC; M/46200/IC, .../MC – Cylinders with Alternative Ports

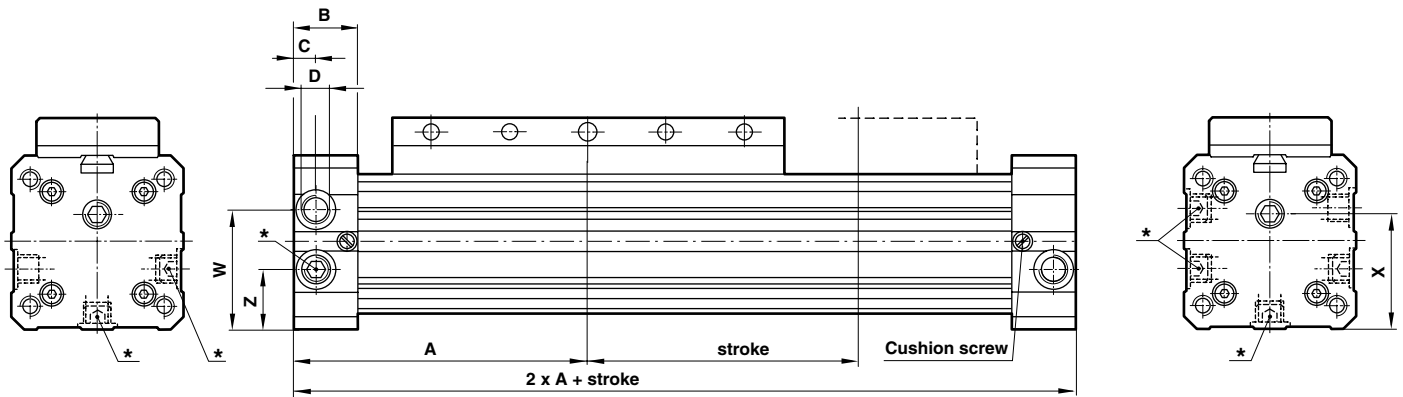

* Alternative ports with inserted plugs.
For full dimensions see page N 1.6.002.06

∅	A	B	C	D	W	X	Z	at 0 mm	per 100
25	100	23	14,5	G 1/8	33	33	17	0,80 kg	0,20 kg
32	120	27	10,5	G 1/4	40	34,5	20	1,60 kg	0,35 kg
40	150	30	11,5	G 1/4	50	43,5	25	2,70 kg	0,50 kg
50	180	35	14	G 3/8	60	53,5	30	4,80 kg	0,75 kg
63	215	40	17	G 1/2	70	61,5	35	7,20 kg	1,00 kg

Dimensions EQM/46000, .../M; EQM/46100, .../M; EQM/46200/, .../M – Cylinders with Valve Adaptors

(order the Excel valves, Model V05X486M-B63*A page N 5.4.042.01, separately)

For cylinders M/46000/IC, .../MC (with internal guide), M/46100/IC, .../MC (with external guide) and M/46200/IC, .../MC (with roller guided carriage)

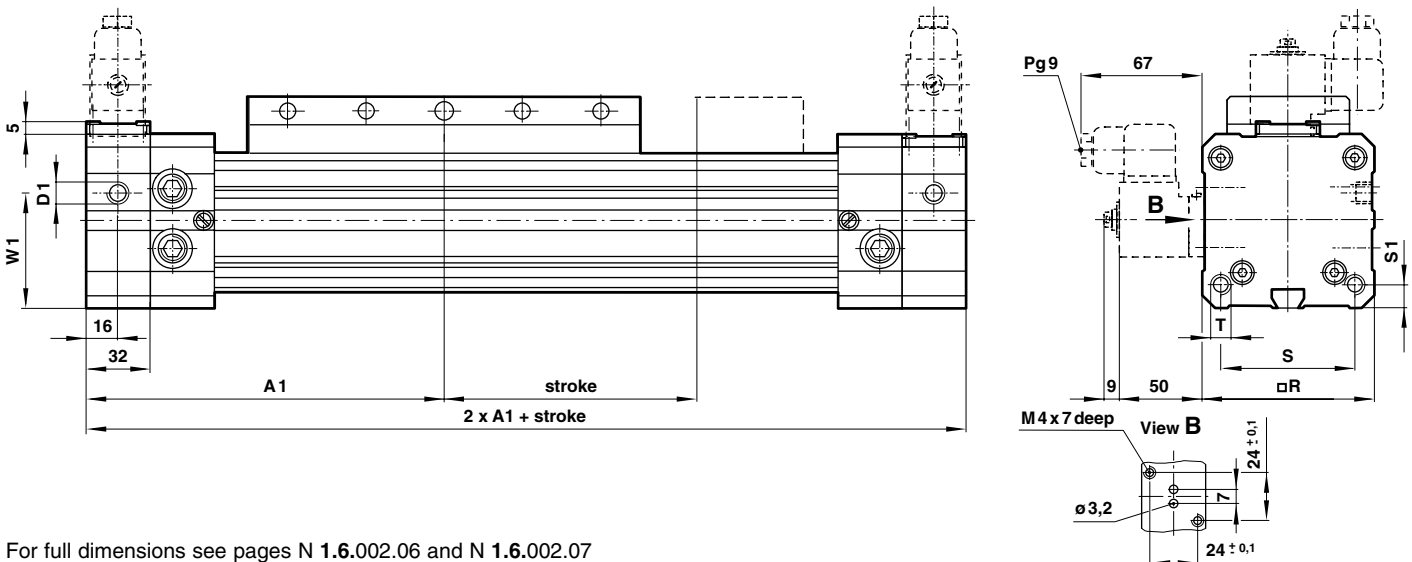

For full dimensions see pages N 1.6.002.06 and N 1.6.002.07

∅	A1	D1	R	S	S1	T	W1	at 0 mm	per 100 mm
25	132	G 1/8	48	37	5,5	M5 x 13 deep	33	1,36 kg	0,20 kg
32	152	G 1/8	60	47	6,5	M6 x 15 deep	34,5	2,40 kg	0,35 kg
40	182	G 1/8	75	58	8,5	M8 x 20 deep	43,5	3,85 kg	0,50 kg
50	212	G 1/8	90	70	10	M8 x 25 deep	53,5	6,40 kg	0,75 kg
63	247	G 1/8	105	84	10,5	M10 x 25 deep	61,5	9,30 kg	1,00 kg



M/46000/L1 and M/46000/L3 – Cylinders with Active Holding Brake

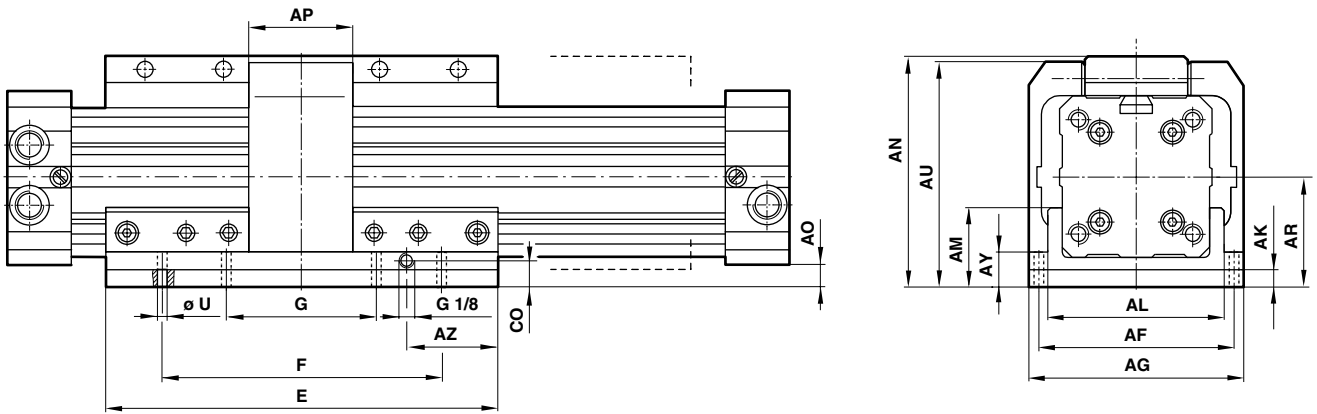

For full dimensions see page N 1.6.002.06

∅	AF	AG	AK	AL	AM	AN	AO	AP	AR	AU	AY	AZ	CO	E	F	G	∅ U	at 0 mm	per 100 mm
25	62	75	12	52	28,5	73,5	13,5	45	37,5	73	16,5	30	6	130	90	45	6,6	1,60 kg	0,20 kg
32	78	92	12	64	29	90	14	55	44	89,5	17,5	32,5	6	160	120	60	9	2,70 kg	0,35 kg
40	94	112	12	81	34,5	103,5	13,5	65	51	103	18	52,5	6	215	160	80	9	4,50 kg	0,50 kg
50	112	132	12	94	35,5	124,5	14,5	75	59,5	124	18,5	65	6	250	190	95	11	7,30 kg	0,75 kg
63	132	150	12	112	42,5	140,5	15,5	90	68	140	20,5	115	6	320	240	120	13	11,50 kg	1,00 kg

To order a cylinder with active holding brake and magnetic piston, ∅ 50 mm and 1000 mm stroke
Quote: M/46050/L3/1000

M/46000/L2 and M/46000/L4 – Cylinders with Passive Holding Brake

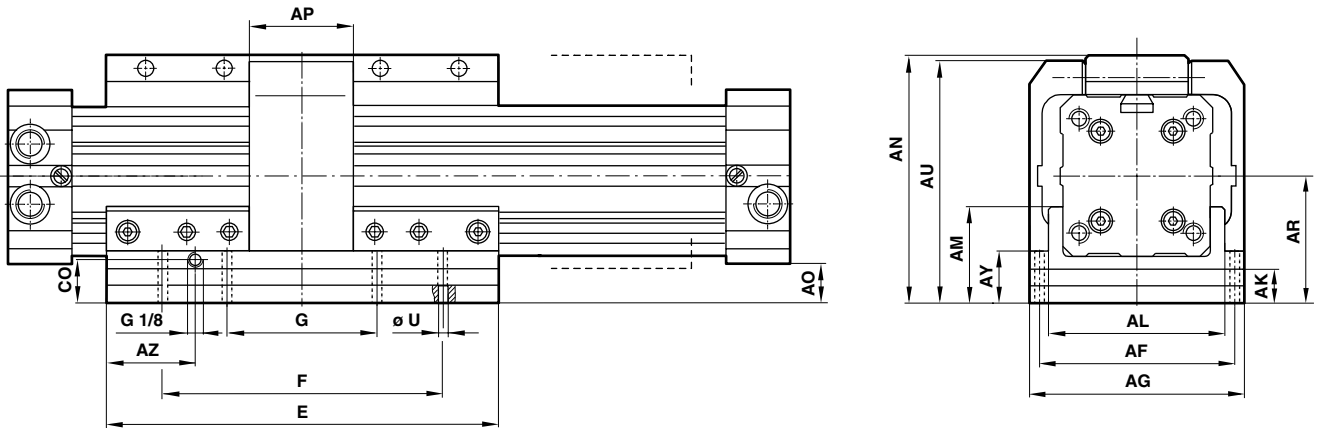

For full dimensions see page N 1.6.002.06

∅	AF	AG	AK	AL	AM	AN	AO	AP	AR	AU	AY	AZ	CO	E	F	G	∅ U	at 0 mm	per 100 mm
25	62	75	22	52	38,5	83,5	23,5	45	47,5	83	26,5	30	16	130	90	45	6,6	1,90 kg	0,20 kg
32	78	92	24	64	41	102	26	55	56	101,5	29,5	32,5	18	160	120	60	9	3,10 kg	0,35 kg
40	94	94	24	81	46,5	115,5	25,5	65	63	115	30	52,5	18	215	160	80	9	5,20 kg	0,50 kg
50	112	112	30	94	53,5	142,5	32,5	75	77,5	142	36,5	65	24	250	190	95	11	8,90 kg	0,75 kg
63	132	132	30	112	60,5	158,5	33,5	90	86	158	38,5	115	24	320	240	120	13	12,40 kg	1,00 kg

To order a cylinder with passive holding brake, ∅ 40 mm and 2000 mm stroke
Quote: M/46040/L2/2000



QM/46100/33, QM/46200/35 – Right Angle Mounting System

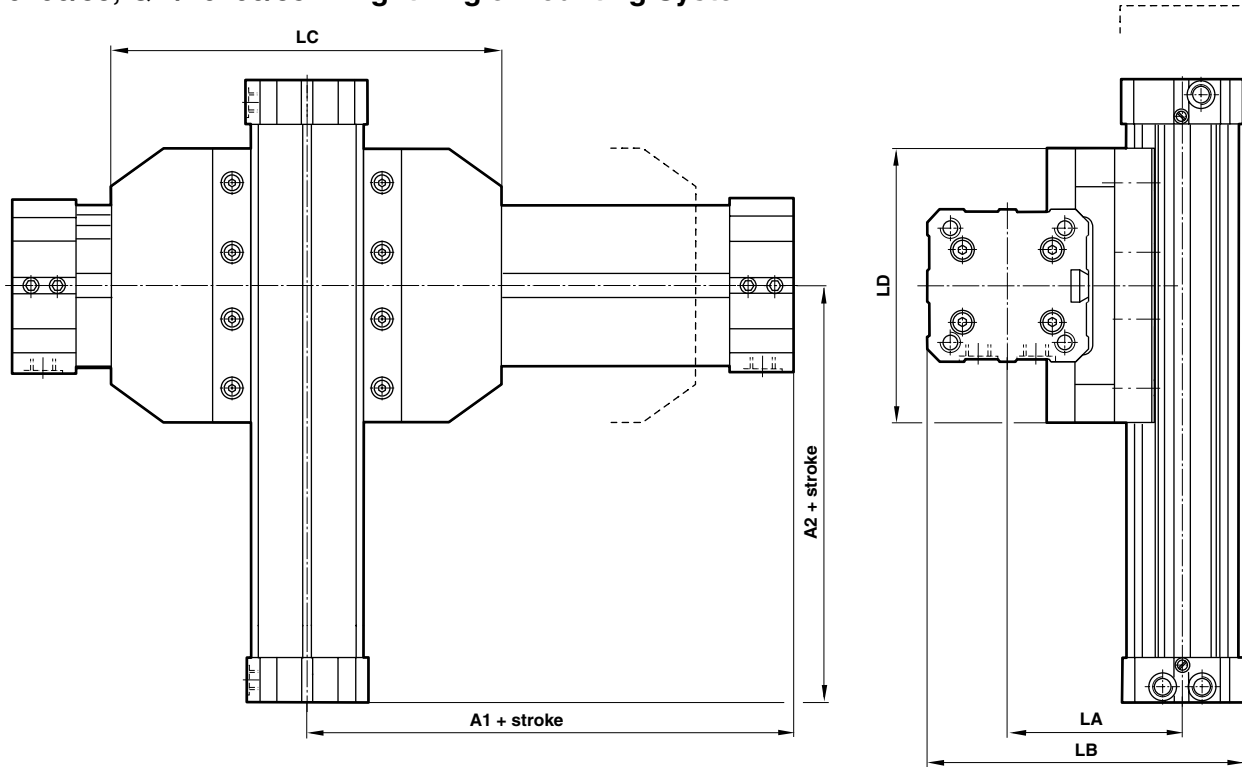

Right Angle Mounting System Externally Guided Same Size Cylinder System Style 'X'

∅	Model (non-magnetic piston)	Model (magnetic piston)	Right angle adaptor	A1+stroke	A2+stroke	LA	LB	LC	LD	Weight
25	QM/46025*/33	QM/46025/M*/33	QM/46125/25/33	100	100	69	117	130	13	1,10 kg
32	QM/46032*/33	QM/46032/M*/33	QM/46132/32/33	120	120	84	144	160	160	1,50 kg
40	QM/46040*/33	QM/46040/M*/33	QM/46140/40/33	150	150	97	172	215	215	2,70 kg
50	QM/46050*/33	QM/46050/M*/33	QM/46150/50/33	180	180	116	206	250	250	3,60 kg

* Insert stroke length. To order Right Angle Mounting System for same size cylinders, Style 'X', order two cylinders of the same bore size together with one Right Angle Adaptor, e.g. 2 off QM/46040*/33 and 1 off QM/46140/40/33.

1st Reduction System Style 'X1'

∅	Model (non-magnetic piston)	Model (magnetic piston)	Right angle adaptor	A1+stroke	A2+stroke	LA	LB	LC	LD	Weight
25	QM/46025*/33	QM/46025/M*/33	QM/46125/20/33	100	85	62	105,5	130	110	1,00 kg
20	QM/46020*/33	QM/46020/M*/33	QM/46125/20/33	100	85	62	105,5	130	110	1,00 kg
32	QM/46032*/33	QM/46032/M*/33	QM/46132/25/33	120	100	76,5	130,5	160	130	1,30 kg
25	QM/46025*/33	QM/46025/M*/33	QM/46132/25/33	120	100	76,5	130,5	160	130	1,30 kg

* Insert stroke length. To order a 1st Reduction Right Angle Mounting System for cylinders of the next bore size smaller, Style 'X1', order two cylinders of successive bore sizes together with one Right Angle Adaptor, e.g. 1 off QM/46025*/33, 1 off QM/46020*/33 and 1 off QM/46125/20/33

2nd Reduction System Style 'X2'

∅	Model (non-magnetic piston)	Model (magnetic piston)	Right angle adaptor	A1+stroke	A2+stroke	LA	LB	LC	LD	Weight
40	QM/46040*/33	QM/46040/M*/33	QM/46140/25/33	150	100	77	138,5	215	130	1,40 kg
25	QM/46025*/33	QM/46025/M*/33	QM/46140/25/33	150	100	77	138,5	215	130	1,40 kg
50	QM/46050*/33	QM/46050/M*/33	QM/46150/32/33	180	120	94	169	250	160	1,80 kg
32	QM/46032*/33	QM/46032/M*/33	QM/46150/32/33	180	120	94	169	250	160	1,80 kg
63	QM/46063*/33	QM/46063/M*/33	QM/46163/40/33	215	150	108	198	320	215	3,80 kg
40	QM/46040*/33	QM/46040/M*/33	QM/46163/40/33	215	150	108	198	320	215	3,80 kg

* Insert stroke length. To order a 2nd Reduction Right Angle Mounting System for cylinders two bore sizes smaller, Style 'X2', order two cylinders of successive bore sizes together with one Right Angle Adaptor, e.g. 1 off QM/46040*/33, 1 off QM/46025*/33 and 1 off QM/46140/25/33

Right Angle Mounting System Roller Guided 2nd Reduction System Style 'X2'

∅	Model (non-magnetic piston)	Model (magnetic piston)	Right angle adaptor	A1+stroke	A2+stroke	LA	LB	LC	LD	Weight
40	QM/46240*/35	QM/46240/M*/35	QM/46240/25/35	150	100	80	141,5	215	130	2,50 kg
25	QM/46225*/35	QM/46225/M*/35	QM/46240/25/35	150	100	80	141,5	215	130	2,50 kg
63	QM/46263*/35	QM/46263/M*/35	QM/46263/40/35	215	150	108	198	320	215	4,00 kg
40	QM/46240*/35	QM/46240/M*/35	QM/46263/40/35	215	150	108	198	320	215	4,00 kg

* Insert stroke length. To order a 2nd Reduction Right Angle Mounting System for cylinders two bore sizes smaller, Style 'X2', order two cylinders of successive bore sizes together with one Right Angle Adaptor, e.g. 1 off QM/46240*/35, 1 off QM/46225*/35 and 1 off QM/46240/25/35



Foot Mounting Style 'C'

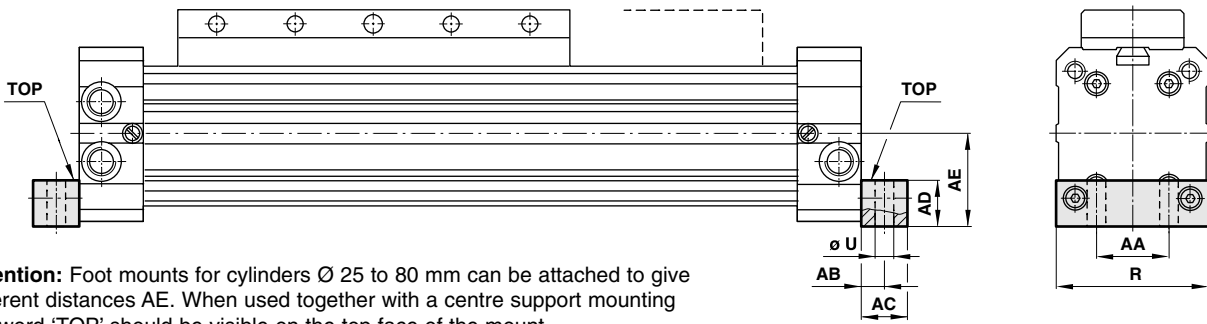

Attention: Foot mounts for cylinders ϕ 25 to 80 mm can be attached to give different distances AE. When used together with a centre support mounting the word 'TOP' should be visible on the top face of the mount.

Centre Support Mounting Style 'V'

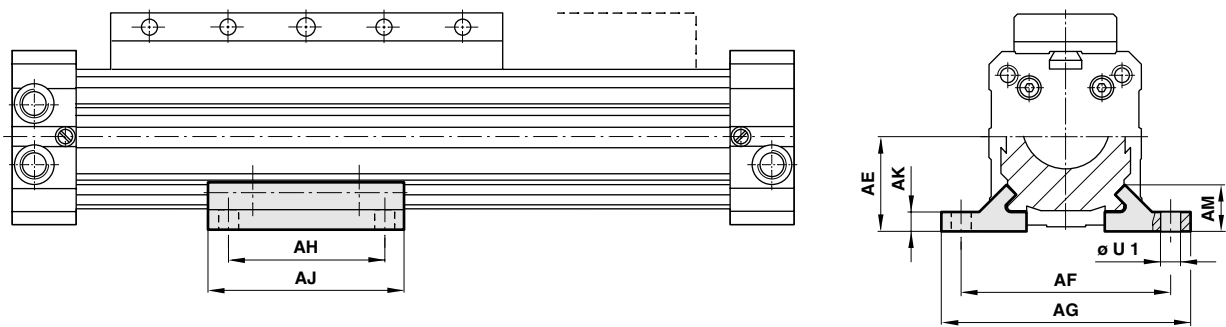

Carriage Mounting Plate Style 'UV'

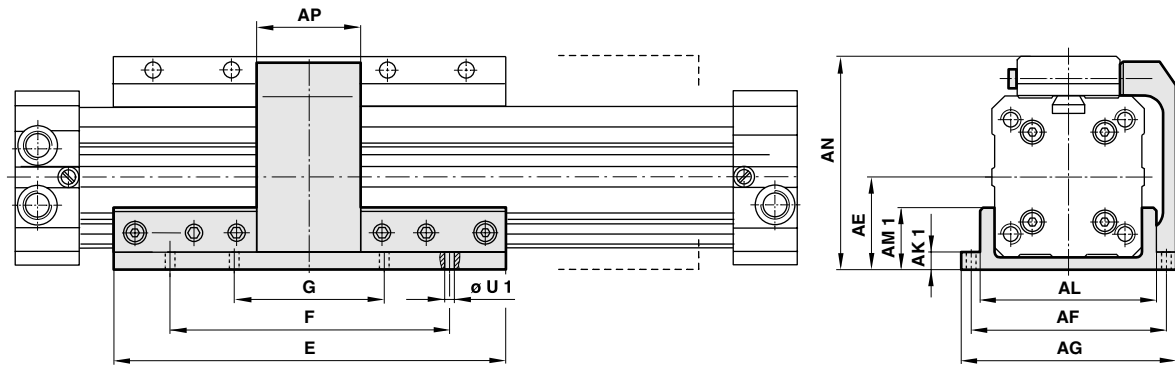

ϕ	AA	AB	AC	AD	AE	AF	AG	AH	AJ	AK	AK1	AL	AM
16	16	10	15	3	16	40	50	20	30	3,5	3,5	31	9
20	17	5	10	10	21,5	52	62	45	60	4,5	5,5	42	12
25	18	7	15	13,5	24 (26,5)	60	72 (75)	60	80	5,5	5,5	52	13
32	26	11	22	16,5	30,5 (33)	76 (78)	92	70	100	6,5	6,5	64	13,5
40	30	11	22	19,5	37,5 (40,5)	92 (94)	108 (112)	90	120	7,5	7,5	81	18,5
50	42	12	25	24	45 (49)	110 (112)	128 (132)	110	140	7,5	8	94	18,5
63	48	13	25	27,5	54 (57,5)	132	154 (150)	120	160	9	10	112	25
80	64	12,5	25	35	70	155	180	140	180	12	10	132	28,3
ϕ	AM1	AN	AP	E	F	G	R	ϕU	$\phi U 1$	Style C	Style UV	Style V	
16	8,5	40,5	30	80	60	—	27	5,5	5,5	0,01 kg	0,10 kg	0,01 kg	
20	14,5	56	36	110	80	40	40	5,5	5,5	0,03 kg	0,20 kg	0,03 kg	
25	17,5	62,5	45	130	90	45	48	7	6,6	0,01 kg	0,30 kg	0,04 kg	
32	18	79	55	160	120	60	60	9	9	0,10 kg	0,40 kg	0,07 kg	
40	24	93	65	215	160	80	75	9	9	0,20 kg	0,80 kg	0,20 kg	
50	25	114	75	250	190	95	90	11	11	0,30 kg	1,20 kg	0,20 kg	
63	32	130	90	320	240	120	105	13	13	0,40 kg	2,00 kg	0,30 kg	
80	32	159	100	390	300	150	130	14	14	0,40 kg	2,90 kg	0,40 kg	

(): Figures in brackets apply for carriage mounting plate Style 'UV'.



Swinging Bridge Mounting Style 'S'

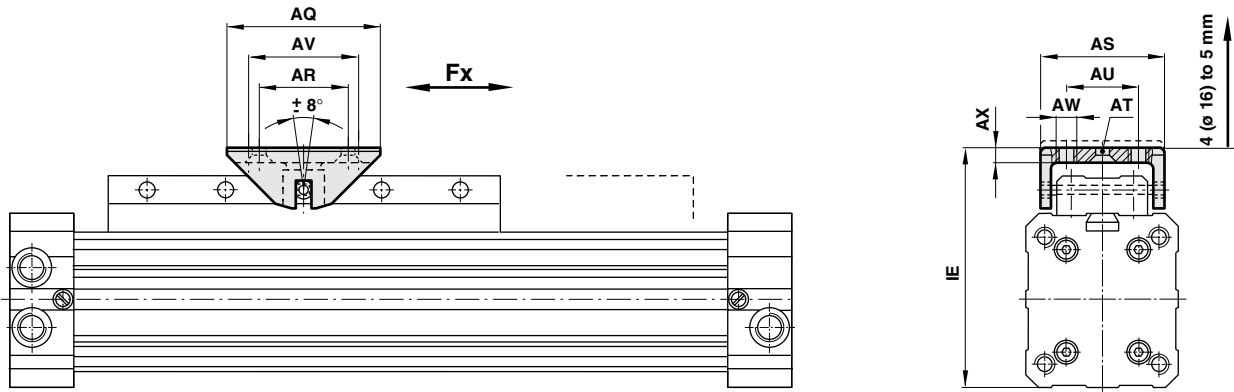

∅	AQ	AR	AS	AT	AU	AV	AW	AX	IE	Fx (N)	Weight
16	40	-	26	-	12	30	M 4	4	48 + 4	100	0,02 kg
20	50	35	38	DIN 74 - Bm 5	20	40	M 5	5	65,5 + 5	150	0,10 kg
25	60	40	44	DIN 74 - Bm 5	20	45	M 5	5	70 + 5	250	0,20 kg
32	80	50	59	DIN 74 - Bm 5	30	60	M 6	5,5	88,5 + 5	410	0,30 kg
40	80	50	59	DIN 74 - Bm 6	30	60	M 6	5,5	102,5 + 5	640	0,30 kg
50	100	60	65	DIN 74 - Bm 8	40	80	M 8	6,5	124 + 5	1000	0,50 kg
63	100	60	65	DIN 74 - Bm 8	40	80	M 8	6,5	139 + 5	1500	0,50 kg
80	100	60	65	DIN 74 - Bm 8	40	80	M 8	6,5	168,5 + 5	2400	0,50 kg

Secondary Carriage (Carriage Free) Style 'W' Side Mounting Plate Style 'UW'

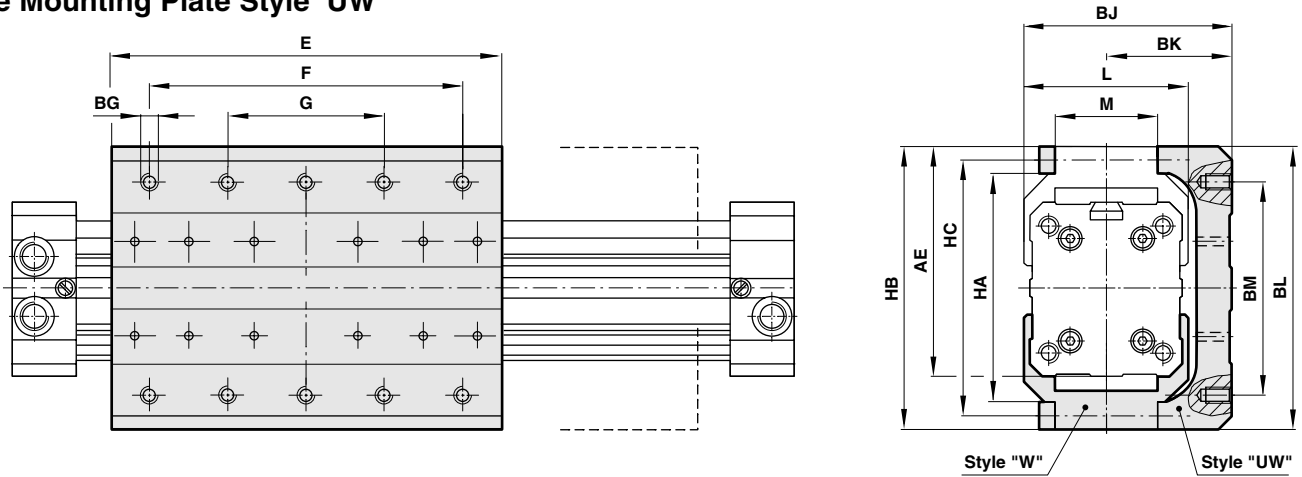

∅	AE	BG	BJ	BK	BL	BM	E	F	G	HA	HB	HC	L	M	Style UW	Style W
16	38	-	54	-	-	-	80	-	-	-	49	-	-	18	-	0,04 kg
20	59	M5 x 10 deep	63	33	78	55	110	80	40	48	79	64	42	27	0,25 kg	0,19 kg
25	67,5	M5 x 10 deep	77	37	86	65	130	90	45	68	87	77	52	32	0,33 kg	0,27 kg
32	82	M5 x 12 deep	98	45	103	80	160	120	60	85	104	94	64	45	0,50 kg	0,50 kg
40	97,5	M5 x 12 deep	117,5	58,5	119	90	215	160	80	99	120	110	79	45	1,08 kg	0,65 kg
50	117	M5 x 15 deep	139,5	71,5	143	120	250	190	95	117	144	131	92	50	1,85 kg	1,10 kg
63	137	M5 x 20 deep	-	84,5	168	140	320	240	120	136	169	154	110	50	3,46 kg	1,90 kg
80	165	-	-	-	-	-	390	-	-	-	200	-	-	50	-	2,50 kg



Assembly Kit Shock Absorber (order plate and shock absorbers separately)

For cylinders M/46100, M/46100/M

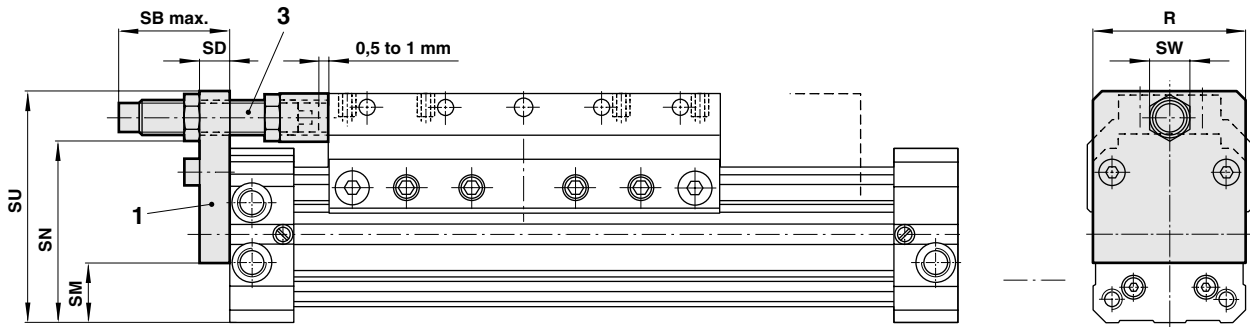

For cylinder M/46200, M/46200/M

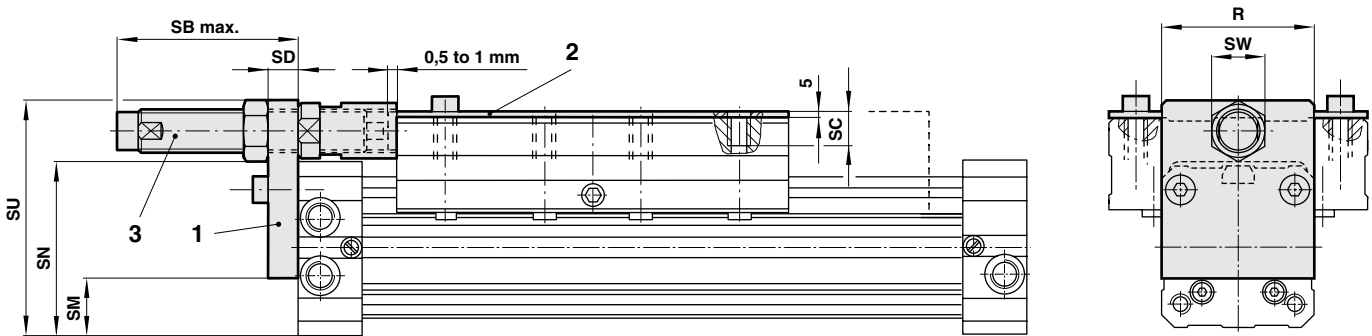

∅	Assembly kit shock absorber Item 1	Plate ** Item 2	Shock absorber ** Item 3	R	SB	SD	SC	SM	SN	SU	SW	Weight
25	QM/46125/67		M/59614/AX, ../BX, ../CX	48	45,5	12	-	19	49	69,5	17	0,11 kg
32	QM/46132/67		M/59614/AX, ../BX, ../CX	60	40,5	12	-	24	61	81,5	17	0,14 kg
40	QM/46140/67		M/59625/AX, ../BX, ../CX	75	81,5	15	-	29	74	109,5	30	0,35 kg
50	QM/46150/67		M/59625/AX, ../BX, ../CX	90	69	15	-	33	91	127,5	30	0,49 kg
63	QM/46163/67		M/59625/AX, ../BX, ../CX	105	69	15	-	41	105,5	141,5	30	0,58 kg
80	QM/46180/67		M/59833/..	130	85	20	-	53	130,5	173,5	∅ 40	0,99 kg
25#	QM/46125/67		M/59614/AX, ../BX, ../CX	48	45,5	12	-	19	49	69,5	17	0,11 kg
32#	QM/46132/67		M/59614/AX, ../BX, ../CX	60	40,5	12	-	24	61	81,5	17	0,14 kg
40#	QM/46140/67	M/P41434	M/59625/AX, ../BX, ../CX	75	81,5	15	31	29	74	109,5	30	0,35 kg (0,30 kg)
50#	QM/46150/67	M/P41435	M/59625/AX, ../BX, ../CX	105	69	15	36	33	91	127,5	30	0,49 kg (0,40 kg)
63#	QM/46163/67	M/P41436	M/59625/AX, ../BX, ../CX	130	69	15	35	41	105,5	141,5	30	0,58 kg (0,60 kg)

Note: Formulae and calculations see page N 1.11.003.01, ** Order plate and shock absorbers separately. # For M/46200, M/46200/M

Attention: When using M/46200 cylinders (∅ 40 to 63 mm) an extra top plate must be mounted onto the carriage as the centre line of the shock absorbers has to be within the surface of the carriage.



LINTRA® Rodless Cylinders M/46000 without top cover

On M/46000 models \varnothing 25 to 80 mm bore the top cover can be removed and the load connected directly to the yoke to provide a useful space saving feature.

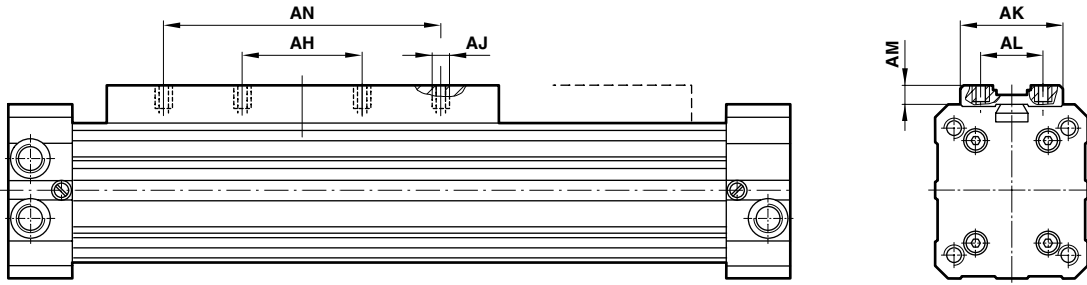

For full dimensions see page N 1.6.002.06

\varnothing	AH	AJ	AK	AL	AM	AN	at 0 mm	per 100 mm
25	25	M5 – 5 deep	27	20	4,5	–	0,70 kg	0,20 kg
32	40	M6 – 6 deep	36	27	6	–	1,40 kg	0,35 kg
40	55	M6 – 6 deep	36	27	5	–	2,45 kg	0,50 kg
50	75	M6 – 8 deep	41	32	7	–	4,50 kg	0,75 kg
63	90	M6 – 8 deep	41	32	6	–	6,80 kg	1,00 kg
80	60	M6 – 8 deep	41	32	7	180	12,70 kg	1,50 kg

M/P72816 – Groove Key

Weight: 0,010 kg

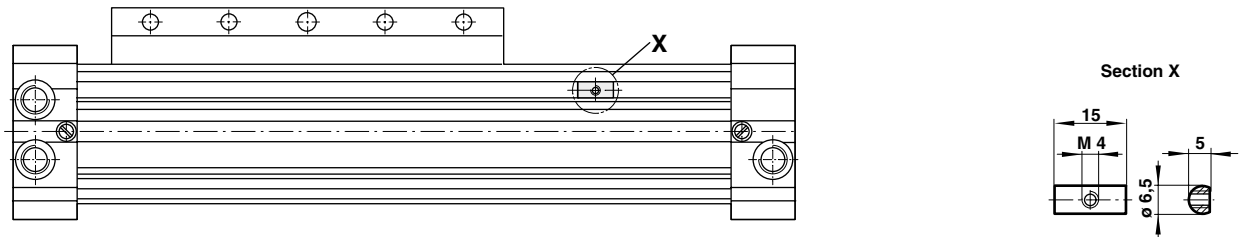

M/K72725/1000 – Groove Cover

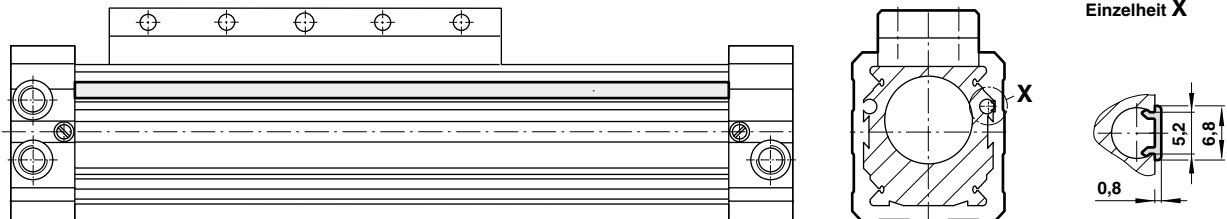



Spares

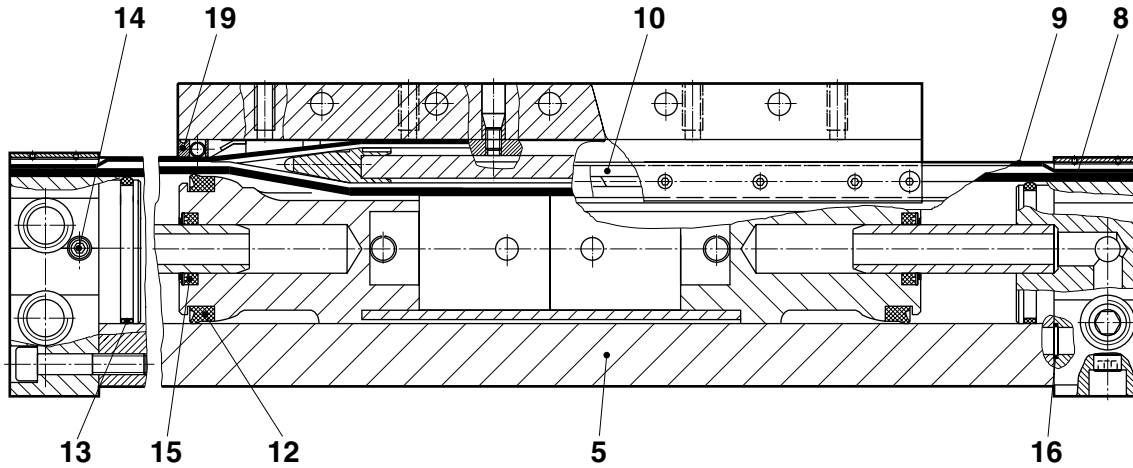

For M/46000, .../M

∅	Model	Spares kit	Comprising Item	Description	Quantity	Seal strip Item 8	Cover strip Item 9
16	M/46016.../M	QM/46016*/88	8 + 9	Seal/cover strip	1	M/P 40270/*	M/P 41101/*
20	M/46020.../M	QM/46020*/88	12	Seal	2	M/P 40262/*	M/P 19567/2/*
25	M/46025.../M	QM/46025*/88	13, 14, 16	O-Ring	2	M/P 40262/*	M/P 19567/2/*
32	M/46032.../M	QM/46032*/88	15	Seal	2	M/P 40344/*	M/P 19587/2/*
40	M/46040.../M	QM/46040*/88	19	Closer assy. Grease	2 1	M/P 40263/*	M/P 19606/2/*
50	M/46050.../M	QM/46050*/88				M/P 40626/*	M/P 19644/2/*
63	M/46063.../M	QM/46063*/88				M/P 40626/*	M/P 19644/2/*
80	M/46080.../M	QM/46080*/88				M/P 40715/*	M/P 41076/*

* Insert stroke length

Note: Please quote the cylinder type number when ordering spare parts

For M/46100, .../M

∅	Model	Spares kit	Comprising Item	Description	Quantity	Seal strip Item 8	Cover strip Item 9
16	M/46116.../M	QM/46116*/88	8 + 9	Seal/cover strip	1	M/P 40270/*	M/P 41101/*
20	M/46120.../M	QM/46120*/88	10	Guide rail	2	M/P 40262/*	M/P 19567/2/*
25	M/46125.../M	QM/46125*/88	12	Seal	2	M/P 40262/*	M/P 19567/2/*
32	M/46132.../M	QM/46132*/88	13, 14, 16	O-Ring	2	M/P 40344/*	M/P 19587/2/*
40	M/46140.../M	QM/46140*/88	15	Seal	2	M/P 40263/*	M/P 19606/2/*
50	M/46150.../M	QM/46150*/88	19	Closer assy. Grease	2 1	M/P 40626/*	M/P 19644/2/*
63	M/46163.../M	QM/46163*/88				M/P 40626/*	M/P 19644/2/*
80	M/46180.../M	QM/46180*/88				M/P 40715/*	M/P 41076/*

* Insert stroke length

Note: Please quote the cylinder type number when ordering spare parts

For M/46200, .../M

∅	Model	Spares kit	Comprising Item	Description	Quantity	Seal strip Item 8	Cover strip Item 9
25	M/46225.../M	QM/46025*/88	8 + 9	Seal/cover strip	1	M/P 40262/*	M/P 19567/2/*
32	M/46232.../M	QM/46032*/88	12	Seal	2	M/P 40344/*	M/P 19587/2/*
40	M/46240.../M	QM/46040*/88	13, 14, 16	O-Ring	2	M/P 40263/*	M/P 19606/2/*
50	M/46250.../M	QM/46050*/88	15	Seal	2	M/P 40626/*	M/P 19644/2/*
63	M/46263.../M	QM/46063*/88	19	Closer assy. Grease	2 1	M/P 40626/*	M/P 19644/2/*

* Insert stroke length

Note: Please quote the cylinder type number when ordering spare parts