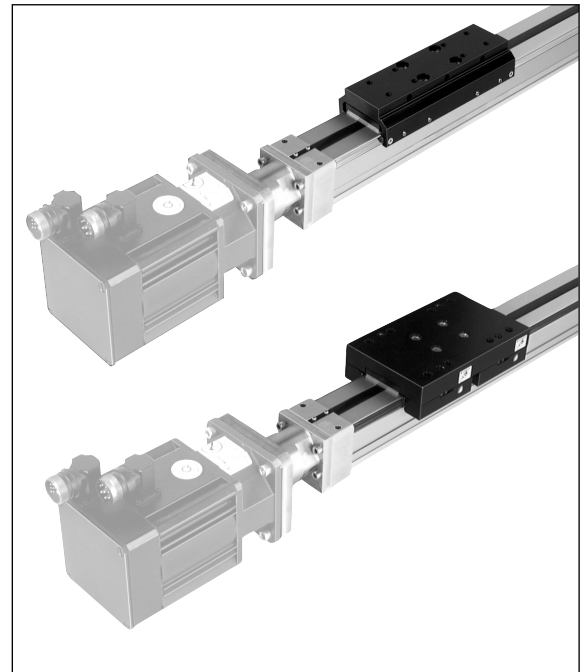

**High forces****Precise positioning****High repeatability****Constant, defined high and low speed operation****Proven LINTRA® guiding systems****Interchangeable with LINTRA® pneumatic cylinders series M/46000****Technical data**

Operation:

Electric spindle drive

Operating temperature:

-20° to +80°C max.

Consult our Technical Service for use below +2°C

Cylinder diameters:

Ø 25, 32, 40, 50, 63 mm

Strokes:

Ø 25 mm: 1250 mm max.

Ø 32, 40, 50, 63 mm: 5000 mm max.

Speed:

2,5 m/s max.

Forces:

500 to 6000 N

Repeatability:

+/-0,05 mm (Single nut)

+/-0,01 mm (Double nut)

Materials

End covers, yoke, carriage, cover and barrel:

anodised aluminium

Cover strip: polyamide

Alternative cylinders

See page N 1.6.055.02

Ordering information

See page N 1.6.055.02

Mountings and sensors

See page N 1.6.055.02





Alternative cylinders

Model	Description	Dimensions see page
M/49000	LINTRA® Spindle with internal guiding, Ø 32, 40, 63 mm	7
M/49100	LINTRA® Spindle with external adjustable guiding, Ø 25, 32, 40, 50, 63 mm	8
M/49200	LINTRA® Spindle with precision roller guiding, Ø 25, 32, 40, 50, 63 mm	8
M/49800	LINTRA® Spindle with heavy duty guiding, Ø 40 mm	9

Options selector

M/49★★★★/★★/★★★★/★★★★

Guidings	Substitute	Ball screw-sizes (mm)	Strokes (mm)
Internal guiding	0	Ø 25	max. 1250
External adjustable guiding	1	Ø 32, 40, 50, 63	max. 5000
Roller guiding	2	Lead screw-sizes (mm)	Strokes (mm)
Heavy duty guiding	8	Ø 25, 32	max. 2700
		Ø 40, 50, 63	max. 2500
		Heavy duty -sizes (mm)	Strokes (mm)
		Ø 40 - Ball screw type	max. 4000
		Ø 40 - Lead screw type	max. 2500
		Number of spindle supports	
		0, 2, 4, 6	See page N 1.6.055.06
		Thread pitch (mm)	
		02 to 50	See page N 1.6.055.03
		Spindle nuts	Substitute
		Single nut (standard)	S
		Double nut (on request)	D

Ordering information

LINTRA® Spindle with external adjustable guiding, Ø 40 mm, ball screw, stroke 2100 mm, 2 spindle supports, 20 mm pitch, single nut, quote: **M/49140/BS/202/2100**

Mountings

Centre support mounting style "V" for LINTRA® spindle Ø 32 mm, quote: **QM/46032/32**

Inductive proximity sensor



Type

Inductive	SPC/008001/2
	SPC/008002/2

Type	Voltage V d.c.	Current max.	Temperature °C	LED	Output	Cable length	Cable	Catalogue page
SPC/008001/2	10 ... 30	200 mA	-30 ... +70	●	Normally closed	2 m	PVC 3x0,14	N 4.3.075.01
SPC/008002/2	10 ... 30	200 mA	-30 ... +70	●	Normally open	2 m	PVC 3x0,14	N 4.3.075.01

Full information on sensors (technical data, cable material, dimensions, etc.) please see catalogue pages N 4.3.075.01.

Mountings and accessories

Ø	Type V Page 10	Bevel gear Page 10	Sensor bracket M/49000 M/49100 M/49200 Page 11	Sensor activator M/49000 Page 11	Sensor activator M/49100 Page 11	Sensor activator M/49200 Page 11
Ø 25	QM/46025/32	SPC/Q008003/20	SPC/Q008003/22	-	SPC/Q008009/21	SPC/Q008014/21
Ø 32	QM/46032/32	SPC/Q008004/20	SPC/Q008004/22	SPC/Q008004/21	SPC/Q008010/21	SPC/Q008015/21
Ø 40	QM/46040/32	SPC/Q008005/20	SPC/Q008004/22	SPC/Q008005/21	SPC/Q008011/21	SPC/Q008016/21
Ø 50	QM/46050/32	SPC/Q008006/20	SPC/Q008004/22	-	SPC/Q008012/21	SPC/Q008017/21
Ø 63	QM/46063/32	SPC/Q008007/20	SPC/Q008004/22	SPC/Q008007/21	SPC/Q008013/21	SPC/Q008018/21

Motor-adaptors for motor-couplings and motors on request.



Spindle types

Spindle types		Ø 25 mm	Ø 32 mm	Ø 40 mm	Ø 50 mm	Ø 63 mm
Ball screw	Spindle Ø (mm)	12	16	20	25	32
	Pitch (mm)	5	5, 10, 20 *	5, 20, 50	5, 10, 25	5, 10, 20, 40
Lead screw	Spindle Ø (mm)	12	16	20	24	30
	Pitch (mm)	2, 4, 6, 12	4, 8	4, 8	5, 10	6, 12

Please note that the operation time of lead screw spindles must not exceed 30 % of the maximum time.

* Max. stroke: 2900 mm with pitch 20 mm. Further pitches on request

Spindle characteristics

Spindle		Max. speed (m/s)*	Max. acceleration (m/s ²)	Repeatability (mm)***	Idle torques (Nm)**
Ø 25	Ball screw	0,25	20	+/- 0,05	0,3
	Lead screw	0,3	5	+/- 0,2	0,4
Ø 32	Ball screw	1,0	20	+/- 0,05	0,6
	Lead screw	0,2	5	+/- 0,2	0,7
Ø 40	Ball screw	2,5	20	+/- 0,05	0,7
	Lead screw	0,2	5	+/- 0,2	0,8
Ø 50	Ball screw	1,25	20	+/- 0,05	0,9
	Lead screw	0,25	5	+/- 0,2	1,0
Ø 63	Ball screw	2,0	20	+/- 0,05	1,0
	Lead screw	0,3	5	+/- 0,2	1,2

* According to screw drive and length (note the rotation speed)

** The idle torques depend on the screw drive, the rotation speed and the adjustment of the guiding

*** Versions with single nut, higher repeatability on request

Loading values for LINTRA® Spindle

The values given in the table below show the maximum single forces in the directions F_y , F_z , F_z' and the maximum moments M_x , M_y and M_z for speed $\leq 0,2$ m/s. A requirement for using these values is a constant movement (no jerking) of the mass over the whole length of the cylinder. The reference point from which the moments for all cylinders should be calculated is the centre line.

Total loads

When a LINTRA® spindle has to take several loads and moments, an additional calculation is necessary using this formula:

$$\frac{M_x}{M_x \text{ max.}} + \frac{M_y}{M_y \text{ max.}} + \frac{M_z}{M_z \text{ max.}} + \frac{F_y}{F_y \text{ max.}} + \frac{F_z (F_z')}{F_z (F_z') \text{ max.}} \leq 1$$

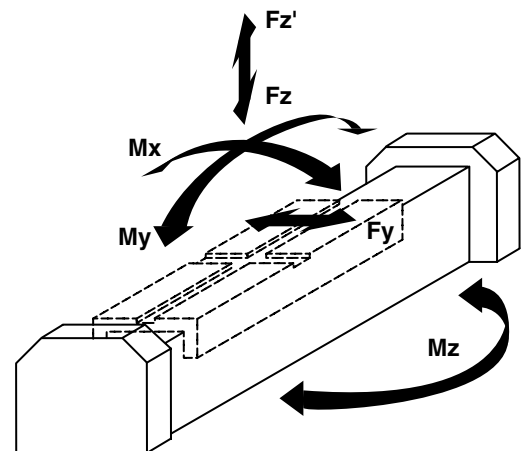

Ø	Internal guiding M/49000			External adjustable guiding M/49100			Precision roller guiding M/49200			Heavy duty guiding M/49800						
	F _x (N)	F _y , F _z /F _{z'} (N)	M _x - M _z (Nm)	F _y , F _z /F _{z'} (N)	M _x (Nm)	M _y , M _z (Nm)	F _y (N)	F _z /F _{z'} (N)	M _x (Nm)	M _y , M _z (Nm)	F _y (N)	F _z (N)	F _{z'} (N)	M _x (Nm)	M _y (Nm)	M _z (Nm)
Ø 25	500	-	-	590	9	28	590	1180	13	42	-	-	-	-	-	-
Ø 32	1200	0	0	780	17	43	780	1560	25	64	-	-	-	-	-	-
Ø 40	3000	0	0	1500	39	110	1500	3000	58	160	4500	5000	4500	450	620	580
Ø 50	4500	-	-	2000	65	160	2000	4000	97	240	-	-	-	-	-	-
Ø 63	6000	0	0	3200	120	350	3200	6400	180	520	-	-	-	-	-	-

Loading values at a speed of $\leq 0,2$ m/s.



Centre support mounting 'V'

In order to prevent exceeding the max. deflection, centre support mountings have to be used.
(For dimensions please see page N 1.6.055.10).

Series M/49000 (Ø 32, 40, 63 mm) – LINTRA® Spindle with internal guiding

The models with internal guiding cannot take any force F_z , therefore, the maximum width between supports depends only on their own weight.

Type	Maximum width between supports
M/49032	1500 mm
M/49040	1650 mm
M/49063	2000 mm

Series M/49100 (Ø 25, 32, 40, 50, 63 mm) – LINTRA® Spindle with external adjustable guiding

M/49125

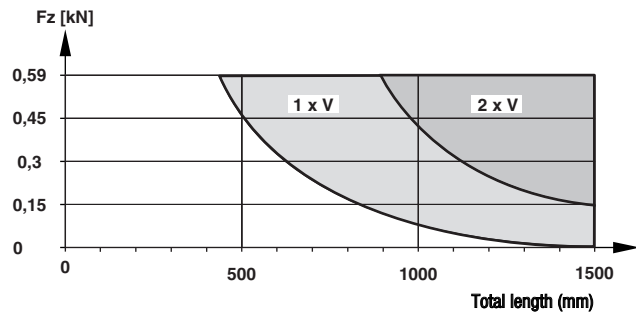

M/49132

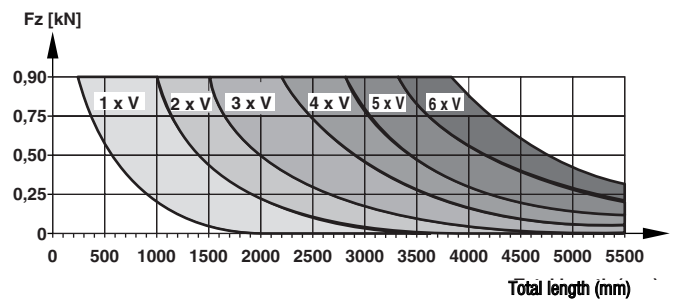

M/49140

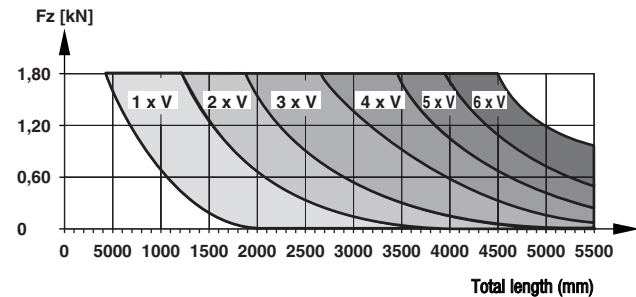

M/49150

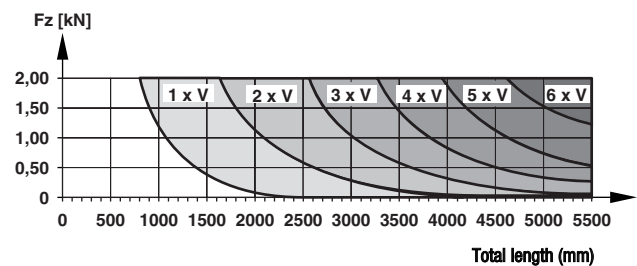

M/49163

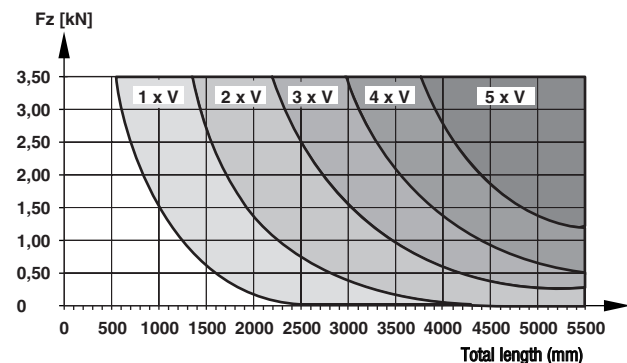



Centre support mounting 'V' (cont'd)

Series M/49200 (Ø 25, 32, 40, 50, 63 mm) – LINTRA® Spindle with precision roller guiding

M/49225

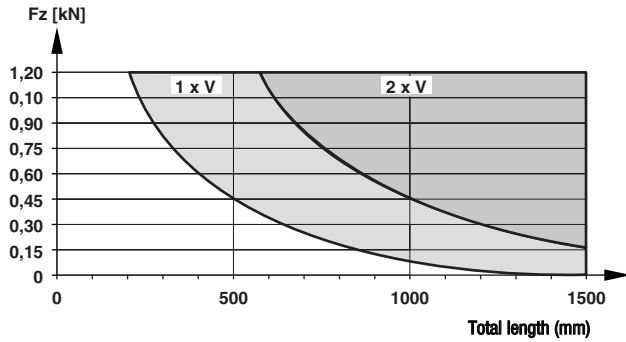

M/49232

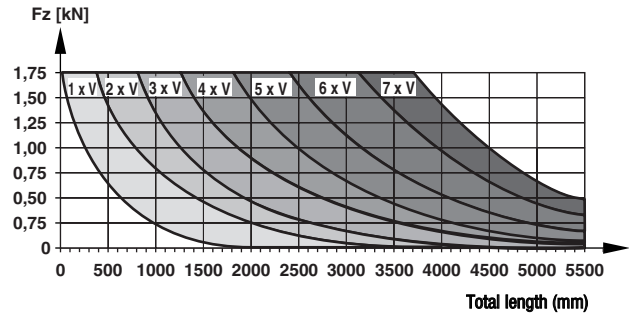

M/49240

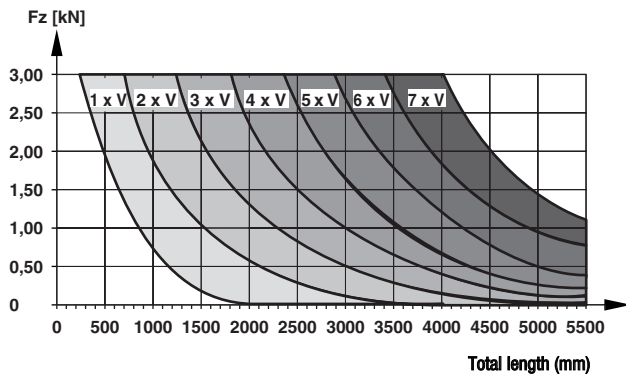

M/49250

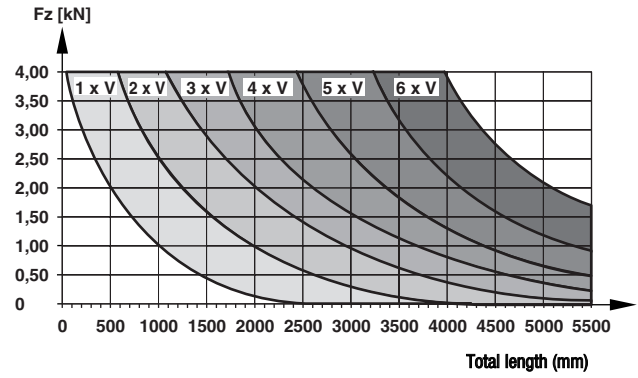

M/49263

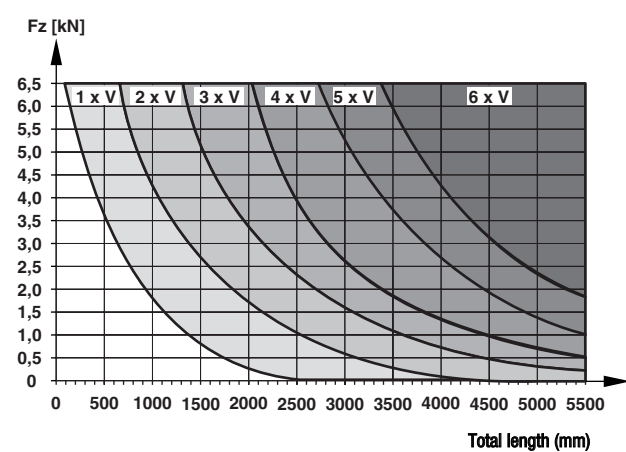



Spindle support (SA)

M/49000 (Ø 32, 40, 63 mm)

M/49100 (Ø 25, 32, 40, 50, 63 mm)

M/49200 (Ø 25, 32, 40, 50, 63 mm)

M/49800 (Ø 40 mm)

Spindle supports (SA) have to be used in order to reach high speed at longer strokes. By using SAs to support the spindle drive the critical rotation speed can be increased. Please refer to the diagrams for the number of SAs. The total length of the spindle actuator is increased by 40 mm per two SAs.

Attention: Please note that the max. rotation speed for lead screws is 1500 min⁻¹ and for ball screws 3000 min⁻¹.

Ø 25 mm

Spindle revolutions (per minute)

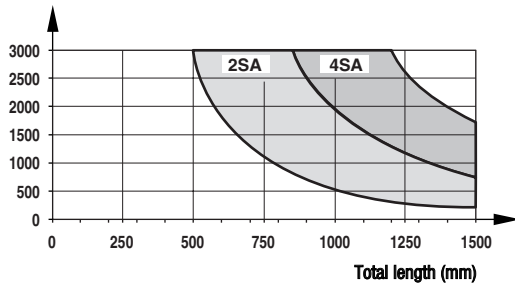

Ø 32 mm

Spindle revolutions (per minute)

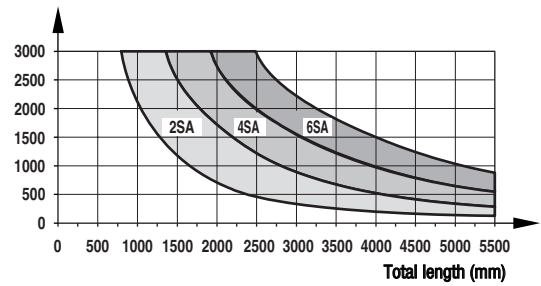

Ø 40 mm

Spindle revolutions (per minute)

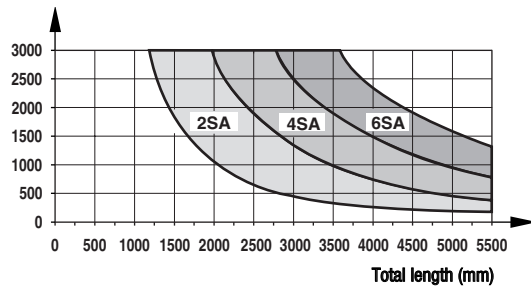

Ø 50 mm

Spindle revolutions (per minute)

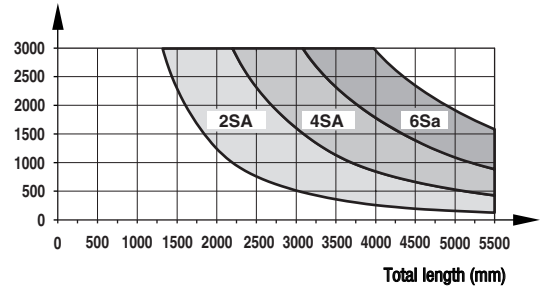

Ø 63 mm

Spindle revolutions (per minute)

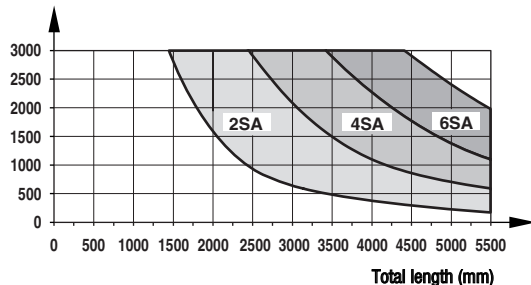



Dimensions

Series M/49000 (Ø 32, 40, 63 mm) – LINTRA® Spindle with internal guiding

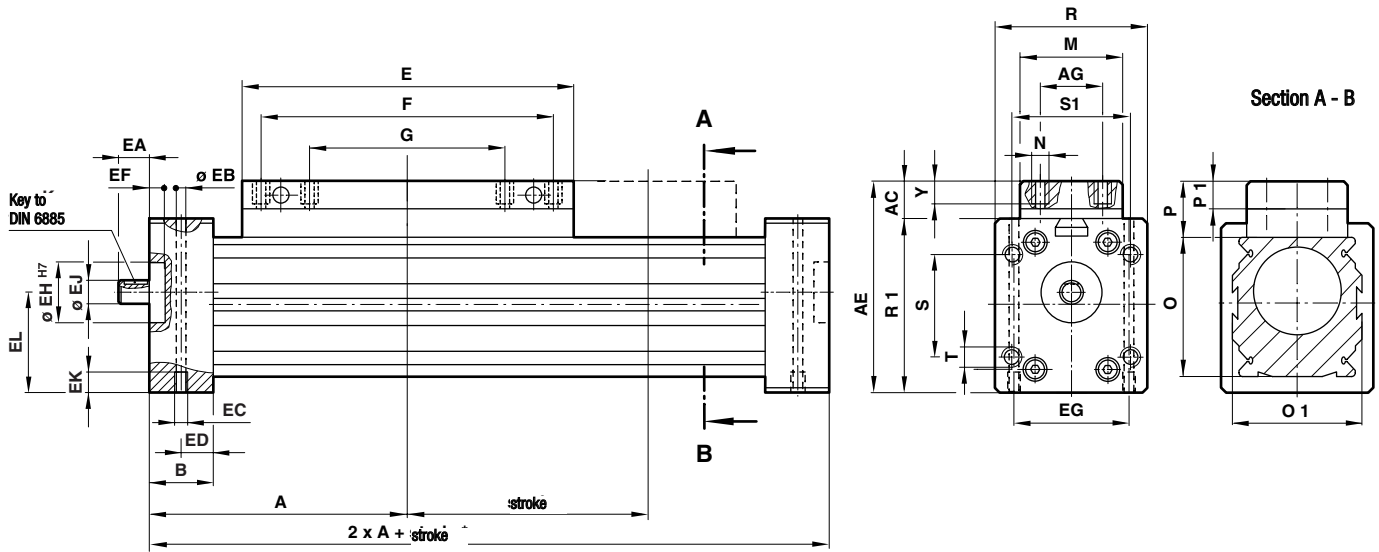

Ø	A	AC	AE	AG	B	E	EA	EB	EC	ED	EF	EG	EH
25	-	-	-	20	23	180	20	5,6	M6	11,5	4	35	22
32	120	16	76	25	27	160	20	5,6	M6	13,5	4	45	28
40	150	15	90	25	30	215	25	6,8	M8	15	3	52	38
50	-	-	-	25	35	250	32	8,5	M10	17,5	5	64	47
63	215	20	125	25	40	320	40	8,5	M10	20	4	75	52
Ø	EJ	EK	F	G	M	N	O	O 1	P	P 1	R	R 1	S
25	9	12	90	45	-	M5	40	40	-	-	48	48	22
32	10	12	120	60	45	M5	52	52	20	10	60	60	27,5
40	12	12	160	80	45	M6	65	65	20	10	75	75	50,9
50	17	20	190	95	-	M8	80	80	-	-	90	90	62,2
63	20	20	240	120	50	M8	95	95	25	14	105	105	74,25
Ø	S 1	T*	W		X	Y	Z	kg at 0 mm		kg per 100 mm			
25	38	M5x13 deep	33		28	7	17	1,8		0,27			
32	47,6	M6x15 deep	40		34,5	8	20	2,5		0,47			
40	50,9	M8x20 deep	50		43,5	8	25	3,4		0,70			
50	62,2	M8x25 deep	60		53,5	11	30	6,1		1,18			
63	74,25	M10x25 deep	70		61,5	11	35	10,5		1,6			

Attention: When using spindle supports (SA) the total length of the spindle actuator is increased by 40 mm per two SAs



Series M/49100 (Ø 25, 32, 40, 50, 63 mm) – LINTRA® Spindle with external adjustable guiding

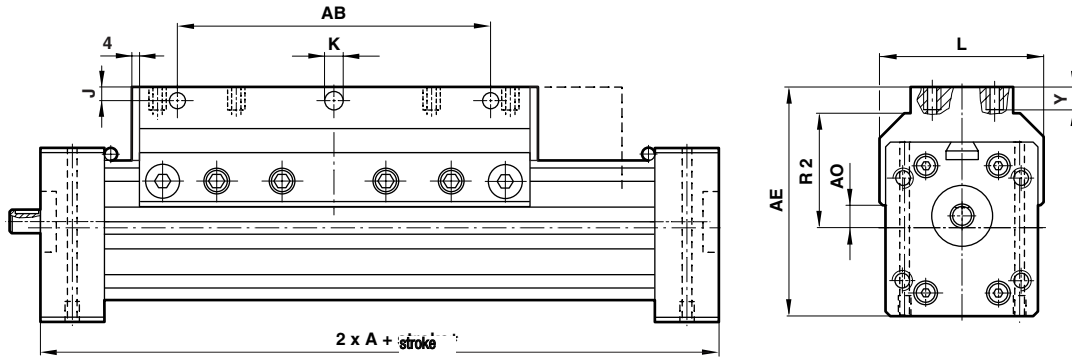

Ø	A	AB	AE	A0	J	Ø K	L	R2	Y	kg at 0 mm	kg per 100 mm
25	100	70	67,5	9,5	5	5,5	52	34	12	1,8	0,27
32	120	90	82	15,5	5	5,5	64	42,5	12	2,5	0,47
40	150	120	97,5	16,5	5	6,6	79	49,5	12	3,4	0,7
50	180	160	117	24	6,5	9	92	58,5	17	6,1	1,18
63	215	190	137	25,5	7,5	9	110	68	20	11	1,56

For full dimensions see page N 1.6.055.07

Attention: When using spindle supports (SA) the total length of the spindle actuator is increased by 40 mm per two SAs

Series M/49200 (Ø 25, 32, 40, 50, 63 mm) – LINTRA® Spindle with precision roller guiding

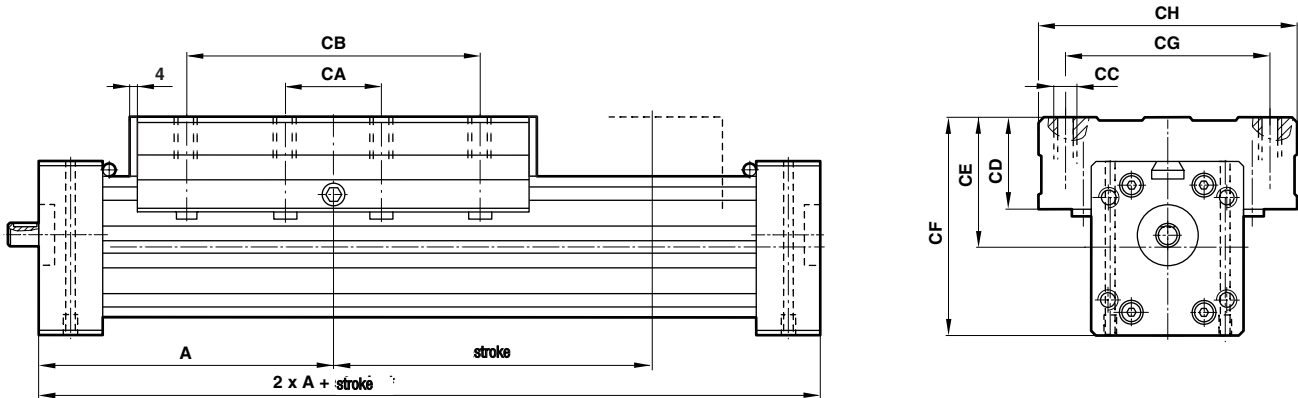

Ø	A	CA	CB	CC	CD	CE	CF	CG	CH	E	kg at 0 mm	kg at 0 mm
25	100	45	90	M6-14 deep	36	42	66	60	85	130	2,5	0,27
32	120	60	120	M8-16 deep	38	50	80	75	98	160	3,9	0,47
40	150	80	150	M8-16 deep	42	57,5	95	92	118	250	10,3	0,18
50	180	90	180	M10-20 deep	44	67	112	100	132	250	10,3	0,18
63	215	120	240	M10-20 deep	47	74,5	127	110	140	320	17,2	1,56

For full dimensions see page N 1.6.055.07

Attention: When using spindle supports (SA) the total length of the spindle actuator is increased by 40 mm per two SAs



Series M/49800 (Ø 40) – LINTRA® Spindle with heavy duty guiding

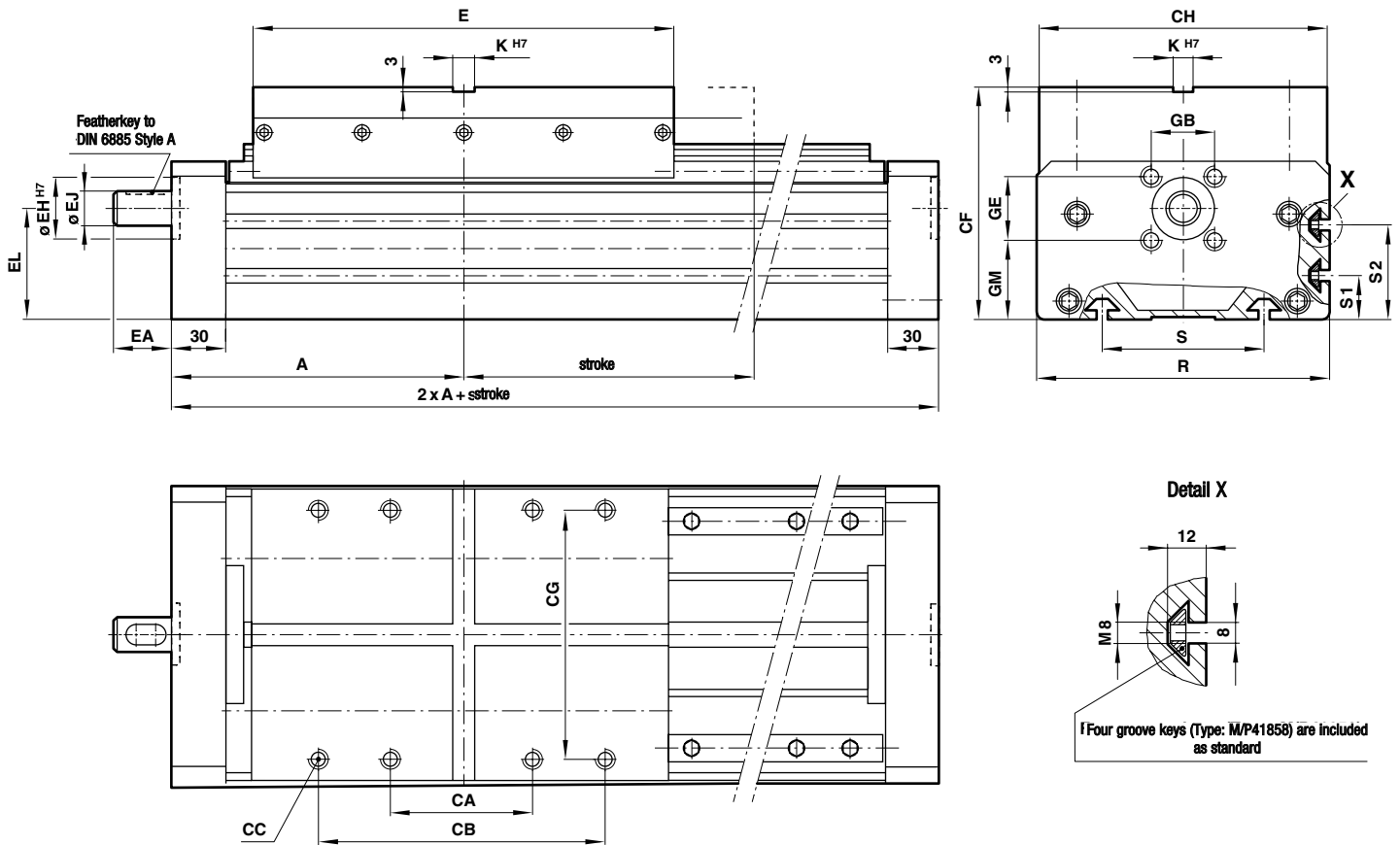

Type	Ø	A	CA	CB	CC	CF	CG	CH	E	EE	K ^{H7}	R	S	S1	S2	Z	kg at 0 mm	kg per 100 mm
M/49840	40	162,5	80	160	M 8 x 33 deep	128	136	162	235	G 1/4	12	164	90	24	52	35	13,1	2,25

For full dimensions see page N 1.6.055.07

Attention: When using spindle supports (SA) the total length of the spindle actuator is increased by 40 mm per two SAs



Centre support mounting 'V'

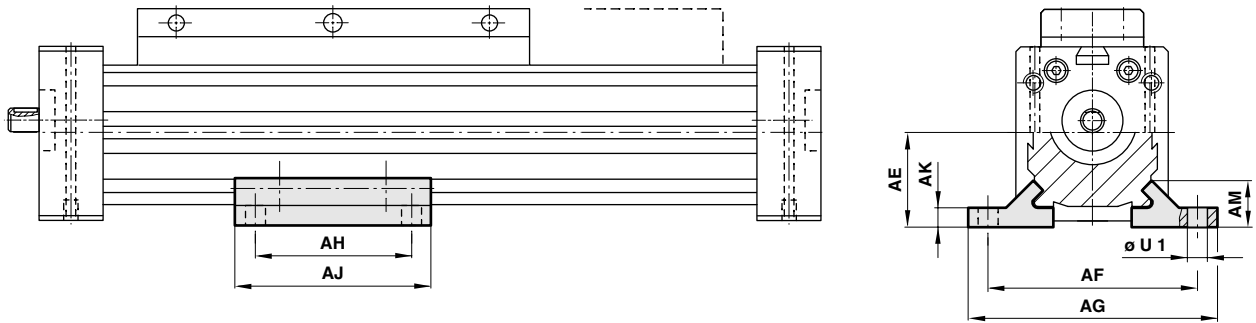

Ø	AE	AF	AG	AH	AJ	AK	AM	Ø U 1	kg
25	24	60	72	60	80	5,5	13	6,6	0,04
32	30,5	76	92	70	100	6,5	13,5	9	0,07
40	37,5	92	108	90	120	7,5	18,5	9	0,20
50	45	110	128	110	140	7,5	18,5	11	0,20
63	54	132	154	120	160	9	25	13	0,30

For the number of centre support mountings please see pages N 1.6.055.04 and 05

Bevel gear SPC/Q00800*/20

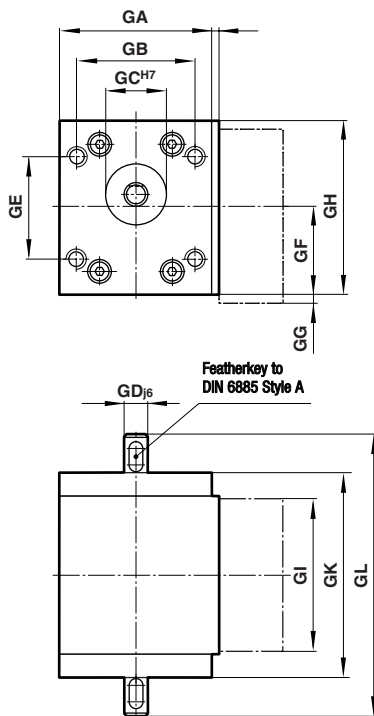

Ø	GA	GB	GC ^{H7}	GD _{j6}	GE	GF	GG	GH	GI	GJ	GK	GL	kg
25	48	38	22 H7-2 deep 20	10 _{j6}	22	24	3,8	48	52	4	70	110	1,7
32	60	47,6	28 H7-2 deep 20	11 _{j6}	27,5	34,7	-	60	64	-	85	125	2,4
25	80	50,9	38 H7-2 deep 20	14 _{j6}	50,9	43,5	-	75	80	-	107	166	3,1
50	90	62,2	47 H7-2 deep 20	19 _{j6}	62,2	45	8,3	90	100	5	128	192	3,6
25	105	74,25	52 H7-2 deep 20	24 _{j6}	74,25	52,5	9,1	105	105	6	135	240	4,2



Accessories

Sensor bracket, sensor activator

Series M/49000 (Ø 32, 40, 63 mm) LINTRA® Spindle with internal guiding

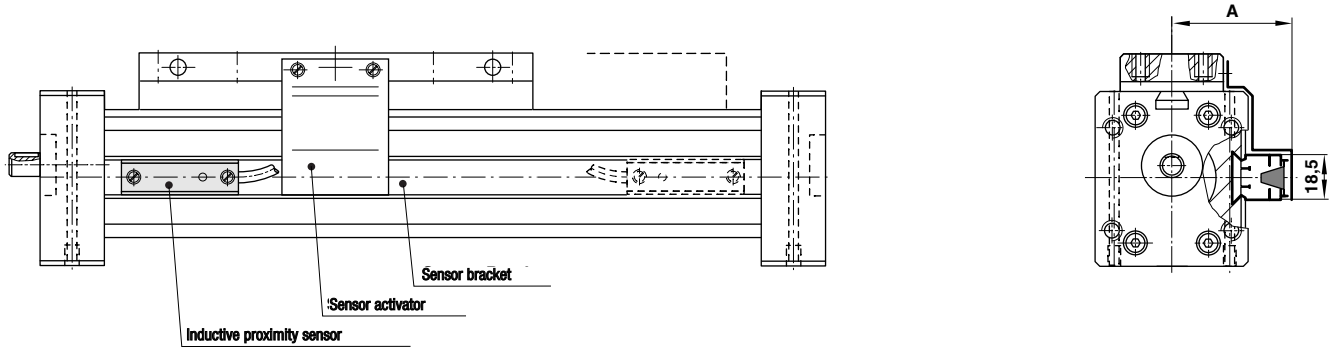

Series M/49100 (Ø 25, 32, 40, 50, 63 mm) LINTRA® Spindle with external adjustable guiding

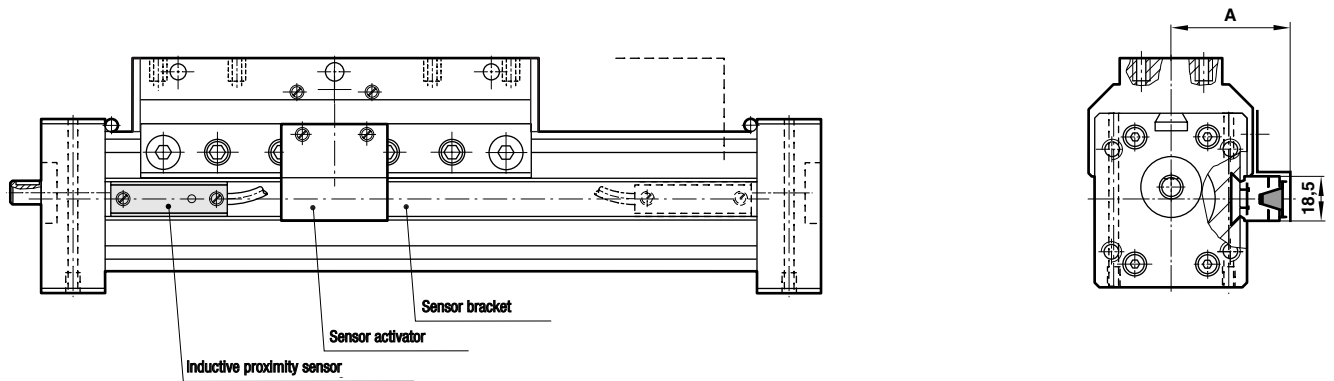

Series M/49200 (Ø 25, 32, 40, 50, 63 mm) LINTRA® Spindle with precision roller guiding

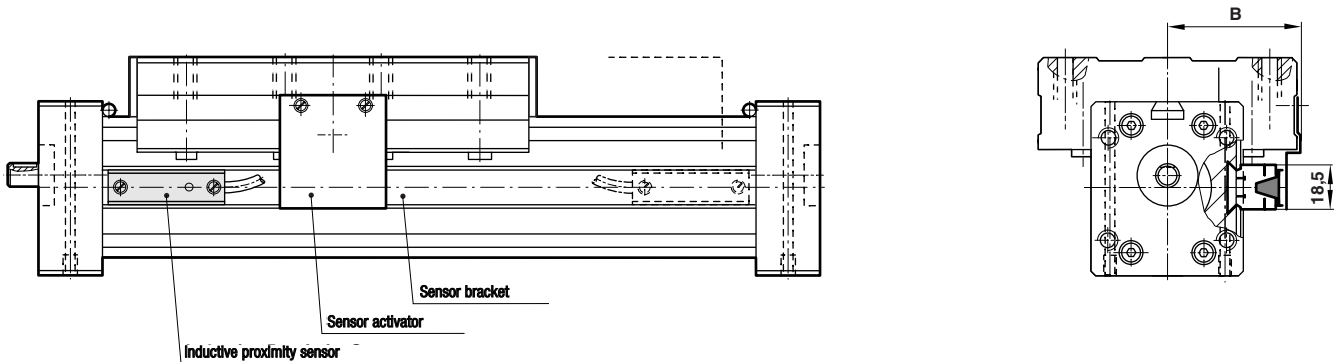

Ø	A	B
25	37	44,5
25	43	51
25	49,5	61
25	57	68
25	64,5	72

For product numbers see page N 1.6.055.02