

M/50100

Clamping cylinders, single acting

- Ø 8 ... 63 mm
- Enable high thrusts to be achieved in restricted space
- Compact design

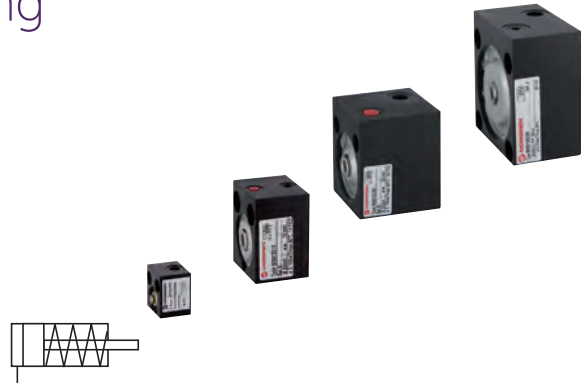

Technical features

Medium:
Compressed air, filtered and lubricated

Operation:
Single acting

Operating pressure:
2 ... 10 bar (29 ... 145 psi)

Cylinder diameters:
8, 12, 20, 32, 50, 63 mm

Standard strokes:
4 ... 25 mm

Operating temperature:
-10 ... +70°C max (+14 ... +158°F)
Air supply must be dry enough to avoid ice formation at temperatures below +2°C (+35°F).

Materials:
Piston rod: stainless steel (austenitic)
Body: anodized aluminium
Seals: NBR

Technical data

Model	M/50108/*	M/50112/*	M/50120/*	M/50120/*	M/50132/*	M/50132/*	M/50150/*	M/50150/*	M/50163/*	M/50163/*		
Cylinder Ø (mm)/	8/4	12/4	12/10	20/4	20/10	32/5	32/10	32/25	50/10	50/25	63/10	63/25
Port size	M5	M5	M5	M5	M5	G1/8	G1/8	G1/8	G1/4	G1/4	G1/4	G1/4
Piston rod Ø (mm)	4	5	5	10	10	12	12	12	16	16	16	16
Piston rod thread	-	-	-	M5	M5	M6	M6	M6	M8	M8	M8	M8
Theoretical thrusts at 6 bar (N)	25	55	55	165	165	445	445	445	1100	1100	1760	1760
Return spring forces F1 instroke (N)	3,4	5,6	5,4	13,2	9,6	25,2	22,3	13,7	36,3	25,5	52,5	41,1
Air consumption at 6 bar outstroke (l/cm)	0,002	0,003	0,008	0,009	0,022	0,028	0,056	0,141	0,138	0,344	0,218	0,546

* Please insert standard stroke length.

Standard strokes

Cylinder Ø (mm)	Strokes (mm)			
	4	5	10	25
8	•	–	–	–
12	•	–	•	–
20	•	–	•	–
32	–	•	•	•
50	–	–	•	•
63	–	–	•	•

Basic dimensions
M/50108 ... M/50112

M/50120 ... M/50163

Dimensions in mm
Projection/First angle

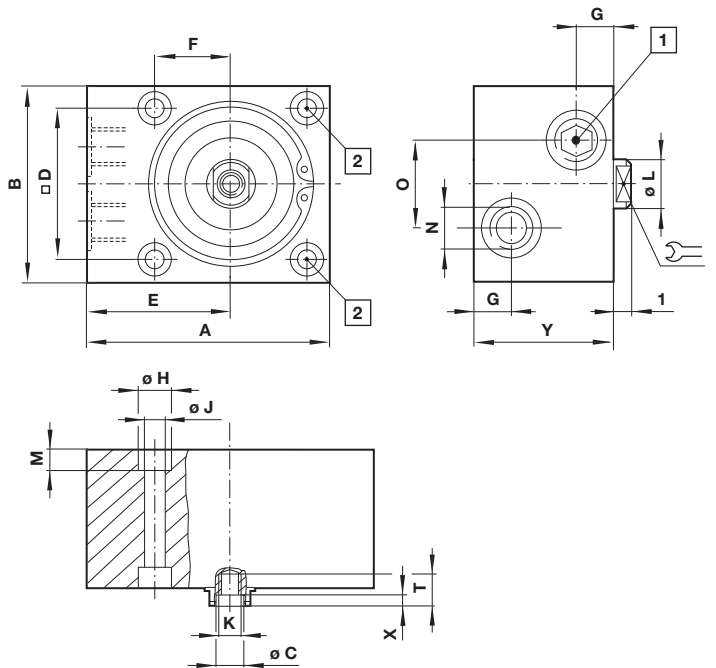
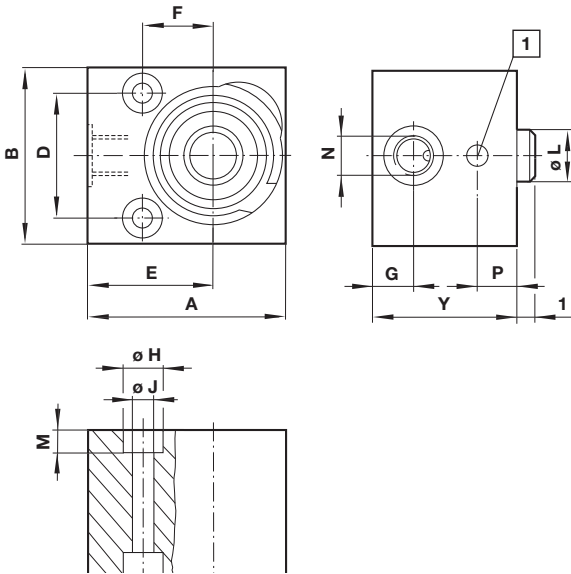

- 1 Exhaust position, do not obstruct
- 2 Ø 20 and 32 mm, without bores

Ø	A	B	Ø C	D	E	F	G	Ø H	Ø J	K	Ø L	M	N	O	P	T	X	Model	
8	20	18	-	11	13,5	8	5	6	3,4	-	4	3,2	M5	-	5	-	-	M/50108/*	
12	25	20	-	13	16	9	5	6	3,4	-	5	3,4	M5	-	4,5	-	-	M/50112/*	
20	40	32	5,3	20	24	15	5	10	5,5	M5	10	5,5	M5	-	4,5	8	8	2	M/50120/*
32	55	45	6,4	32	32	18	10	10	5,5	M6	12	5,5	G1/8	20	-	10	14,5	2,5	M/50132/*
50	80	65	8,4	50	47,5	25	12	11	6,6	M8	16	6,8	G1/4	30	-	13	15	3	M/50150/*
63	90	80	8,4	62	50	31	12	15	9	M8	16	9	G1/4	30	-	13	15	3	M/50163/*

Ø	Stroke	Y	kg	Model
8	4	15	0,02	M/50108/4
12	4	15	0,03	M/50112/4
12	10	23	0,04	M/50112/10
20	4	20	0,1	M/50120/4
20	10	26	0,1	M/50120/10
32	5	26	0,22	M/50132/5
32	10	31	0,25	M/50132/10
32	25	46	0,31	M/50132/25
50	10	30	0,5	M/50150/10
50	25	45	0,6	M/50150/25
63	10	35	0,8	M/50163/10
63	25	50	1,05	M/50163/25

Warning

These products are intended for use in industrial compressed air systems only. Do not use these products where pressures and temperatures can exceed those listed under »**Technical features/ data**«.

Before using these products with fluids other than those specified, for non-industrial applications, life-support systems or other applications not within published specifications, consult Norgren.

Through misuse, age, or malfunction, components used in fluid power systems can fail in various modes.

The system designer is warned to consider the failure modes of all component parts used in fluid power systems and to provide adequate safeguards to prevent personal injury or damage to equipment in the event of such failure.

System designers must provide a warning to end users in the system instructional manual if protection against a failure mode cannot be adequately provided.

System designers and end users are cautioned to review specific warnings found in instruction sheets packed and shipped with these products.