

PRA/862000/M IVAC Industrial cylinder Magnetic piston, double acting

- Ø 32 ... 100 mm
- Cylinders and mountings conform to ISO 15552
- Complete functional unit
- Integrated 5/2 or 5/3 valve
- With food grade lubricant (white-listed NSF H1 lubricant and certified according to ISO 21469)
- Additional output ports (2 & 4)
- Integrated flow regulator for speed control
- Reed or solid state switches can be mounted flush with the profile barrel
- Protection class IP65
- Energy efficient

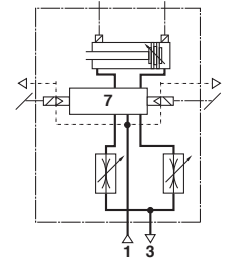

Technical features

Medium:

Compressed air, filtered, lubricated or non-lubricated
 Particles size: Class 7, ISO 8573 – 1 (dated 2001)
 Humidity and water content:
 Air supply must be dry.
 Corresponding of the application and working conditions the air must be dry enough to avoid condensate. The pressure dewpoint must be minimum 15° under the application and working conditions. Oil: Class 4,

ISO 8573 – 1 (dated 2001)

Standard:

Based on ISO 15552 (length, mounting pitch and thread dimensions according to ISO 15552. Some outside dimensions different to ISO 15552)

Operation:

Double acting, magnetic piston, adjustable cushioning

Operating pressure:

2 ... 8 bar (29 ... 116 psi)

Port size:

G1/8, G1/4, G3/8

Cylinder diameters:

32, 40, 50, 63, 80, 100 mm

Standard strokes: See below

Non-standard strokes:
 Available (25 ... 1000 mm)

Operating temperature:

-5 ... +80°C max. (+23 ... +176°F)

Supply voltage:

24 V d.c. (±10 %) (other voltages supply on request)

Power consumption:

2 W max

Electrical connection:

DIN EN175301-803, form C

Manual override:

Turn and lock

Rating:

100 % E.D.

Protection class:

IP 65

Life expectation of the cylinder: *1)
 Stroke < 100 mm: 10 Mio. Cycles
 Stroke > 100 mm: 5000 km

Life expectation of the solenoid valves: 50 Mio. Cycles

*1) Life expectation based on laboratory conditions (more details upon request):

- Operating pressure: 8 bar
- Compressed air: ISO 8573-1,

Class 7-4-4

- Ambient temperature: 20° C +/--10° C
- Environment: Industrial plant, no contamination such as dust and/or moisture or similar
- Position: horizontal
- Side load: max. transverse load approx. 1.3% of the theoretical force at 6 bar
- Speed: 1,0 m/s for Ø 32 to 50 mm
0,7 m/s for Ø 63 to 100 mm
- Frequency: < 20 cycles / min (in/out)

Materials:

Profile barrel: anodised aluminium,
 End covers: pressure diecast anodised aluminium
 Piston rod: stainless steel, see page 2
 Piston rod seals: PUR
 Piston seals: NBR
 O-rings: NBR

Technical data

Cylinder Ø (mm)	32	40	50	63	80	100
Port size	G 1/8	G 1/8	G 1/8	G 1/4	G 1/4	G 3/8
Piston rod Ø (mm)	12	16	20	20	25	25
Piston rod thread	M10 x 1,25	M12 x 1,25	M16 x 1,5	M16 x 1,5	M20 x 1,5	M20 x 1,5
Cushion length (mm)	11	14	14	19	19	26
Theoretical thrusts at 6 bar outstroke (N)	482	754	1178	1870	3016	4710
Theoretical thrusts at 6 bar instroke (N)	414	633	990	1680	2722	4416
Air consumption at 6 bar outstroke (l/cm)	0,056	0,088	0,137	0,218	0,35	0,55
Air consumption at 6 bar instroke (l/cm)	0,05	0,076	0,117	0,198	0,324	0,514

Reduced Installation Time & Cost

To connect the IVAC you simply run a single ring main to provide an air supply to each unit. There is no mounting of valve islands to the machine framework or inside a cabinet and there is no pipework to run around the machine to connect each valve to each actuator

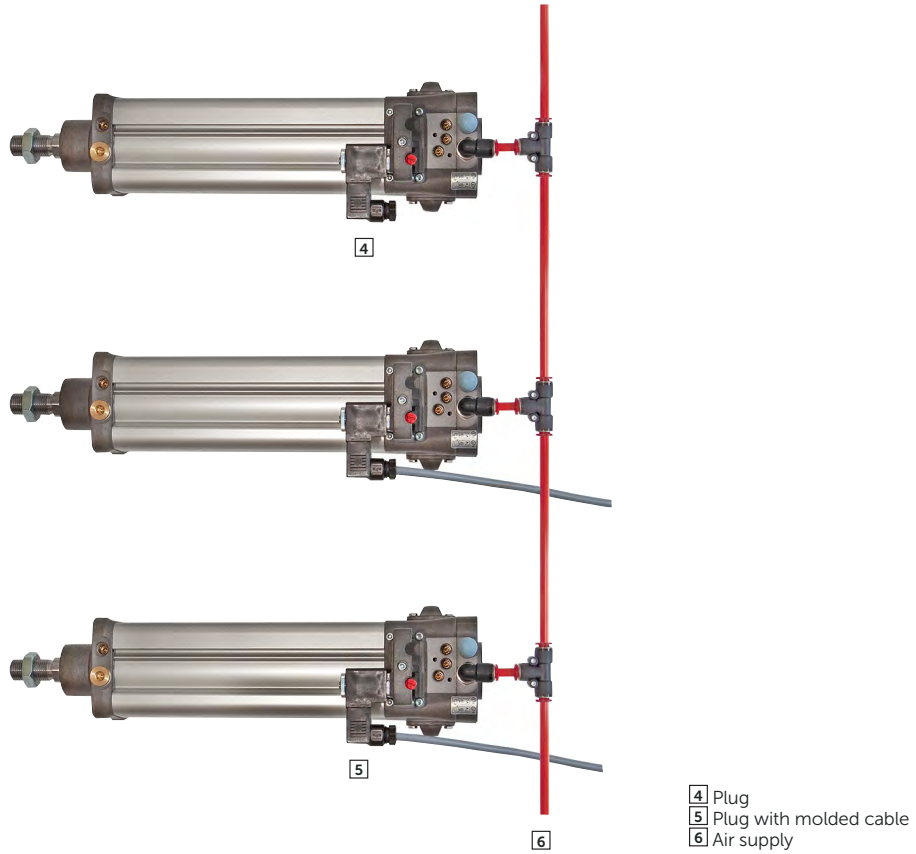

One of the advantages of the IVAC cylinders is to use the output ports (2 & 4) from the main valve to operate an additional cylinder.

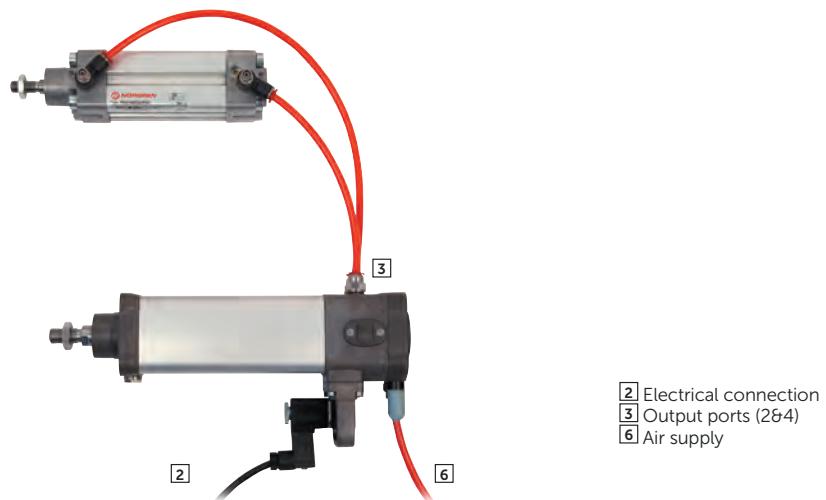



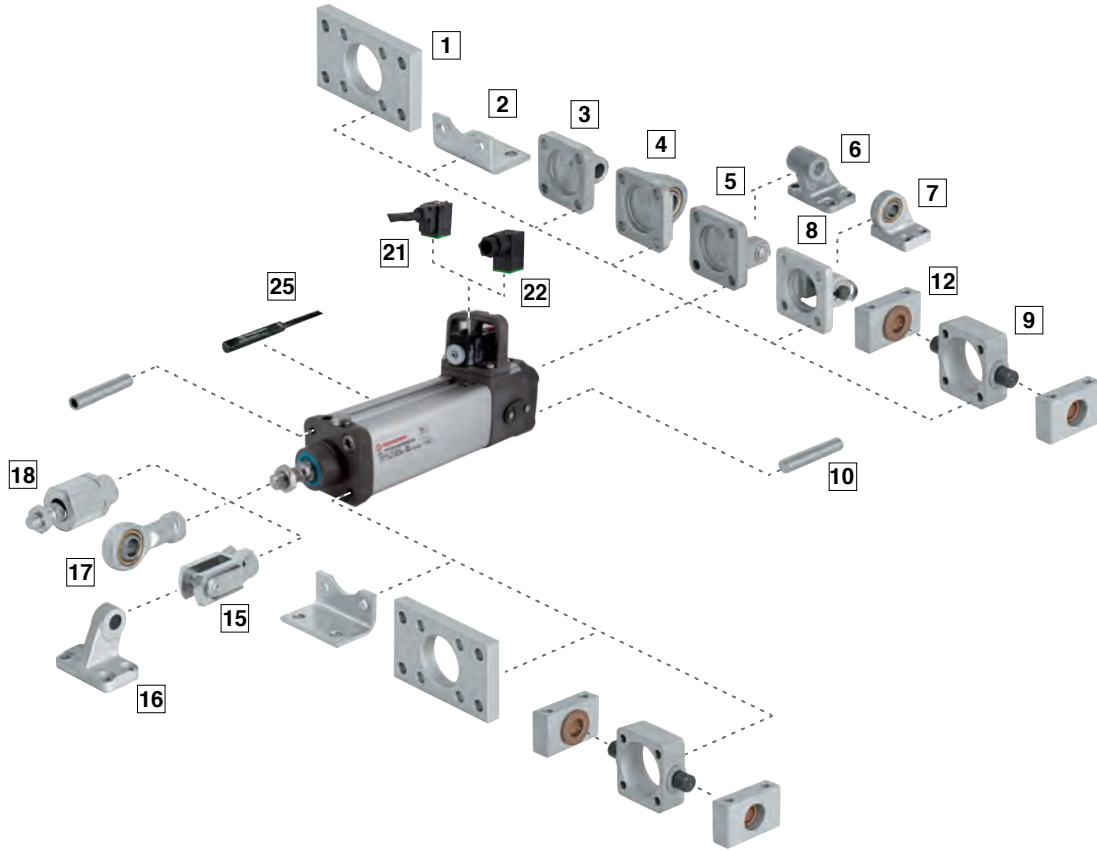











Mountings



Position	Style	Standard	Corrosion protected
1	B, G	Clear anodised aluminium	Clear anodised aluminium. Screws: A2
2	C	Galvanized steel (∅ 32 ... 63 mm) Painted steel (∅ 80 & 100 mm)	–
3	R	Diecast aluminium	Black corrosion protected diecast aluminium. Certified for the food industry. Screws: A2
4	UR	Galvanized aluminium Inner ring: steel Outer ring: brass	Black corrosion protected diecast aluminium Certified for the food industry Inner ring: stainless Steel (austenitic) Outer ring: nickel plated hardened steel
5	D	Diecast aluminium Bolt: galvanized steel (martensitic) Circlip: galvanized steel	Black corrosion protected diecast aluminium Certified for the food industry Bolt: X 10 Cr Ni S 18 9 (1.4305, AISI 303) Circlip: Stainless steel (martensitic). Screws: A2
6	SW	Diecast aluminium	Black corrosion protected diecast aluminium Certified for the food industry
7	US	Galvanized aluminium. Inner ring: steel Outer ring: brass	–
8	D2	Painted cast iron. Bolt: stainless steel (martensitic) Circlip: galvanized steel	–
9	FH	Cast iron	–
10	A	Galvanized steel	–
11	Screw	–	–
12	S	Clear anodised aluminium Bearing: brass	–
15	F	Galvanized steel Bolt: galvanized steel Circlip: Galvanized steel	Nickel plated steel Circlip: X 10 Cr Ni S 18 9 (1.4305, AISI 303) Bolt: X 10 Cr Ni S 18 9 (1.4305, AISI 303)
16	SS	Painted cast iron	–
17	UF	Galvanized steel. Inner ring: steel Outer ring: brass	Nickel plated steel. Inner ring: stainless steel (austenitic) Outer ring: nickel plated hardened steel.
18	AK	Galvanized steel	–

Mountings

Model	A	AK	B, G	C	D	D2	F	FH
Cyl. Ø	 10 Page 9	 18 Page 9	 1 Page 9	 2 Page 9	 5 Page 9	 8 Page 9	 15 Page 10	 9 Page 10
32	QM/8032/35	QM/8025/38	QA/8032/22	QA/8032/21	QA/8032/23	QA/8032/42	QM/8025/25	QA/8032/34
40	QM/8032/35	QM/8040/38	QA/8040/22	QA/8040/21	QA/8040/23	QA/8040/42	QM/8040/25	QA/8040/34
50	QM/8050/35	QM/8050/38	QA/8050/22	QA/8050/21	QA/8050/23	QA/8050/42	QM/8050/25	QA/8050/34
63	QM/8050/35	QM/8050/38	QA/8063/22	QA/8063/21	QA/8063/23	QA/8063/42	QM/8050/25	QA/8063/34
80	QM/8080/35	QM/8080/38	QA/8080/22	QA/8080/21	QA/8080/23	QA/8080/42	QM/8080/25	QA/8080/34
100	QM/8080/35	QM/8080/38	QA/8100/22	QA/8100/21	QA/8100/23	QA/8100/42	QM/8080/25	QA/8100/34
Corrosion protected								
32	–	–	PVQA/8032/22	–	PVQA/8032/23	–	PVQM/8025/25	–
40	–	–	PVQA/8040/22	–	PVQA/8040/23	–	PVQM/8040/25	–
50	–	–	PVQA/8050/22	–	PVQA/8050/23	–	PVQM/8050/25	–
63	–	–	PVQA/8063/22	–	PVQA/8063/23	–	PVQM/8050/25	–
80	–	–	PVQA/8080/22	–	PVQA/8080/23	–	PVQM/8080/25	–
100	–	–	PVQA/8100/22	–	PVQA/8100/23	–	PVQM/8080/25	–
Cyl. Ø	 3 Page 10	 12 Page 10	 16 Page 11	 6 Page 11	 17 Page 10	 4 Page 11	 7 Page 12	
32	QA/8032/27	QA/8032/41	M/P19931	M/P19493	QM/8025/32	QA/8032/33	M/P40310	
40	QA/8040/27	QA/8040/41	M/P19932	M/P19494	QM/8040/32	QA/8040/33	M/P40311	
50	QA/8050/27	QA/8040/41	M/P19933	M/P19495	QM/8050/32	QA/8050/33	M/P40312	
63	QA/8063/27	QA/8063/41	M/P19934	M/P19496	QM/8050/32	QA/8063/33	M/P40313	
80	QA/8080/27	QA/8063/41	M/P19935	M/P19497	QM/8080/32	QA/8080/33	M/P40314	
100	QA/8100/27	QA/8100/41	M/P19936	M/P19498	QM/8080/32	QA/8100/33	M/P40315	
Corrosion protected								
32	PVQA/8032/27	–	–	M/P40459	PVQM/8025/32	PVQA/8032/33	–	
40	PVQA/8040/27	–	–	M/P40460	PVQM/8040/32	PVQA/8040/33	–	
50	PVQA/8050/27	–	–	M/P40461	PVQM/8050/32	PVQA/8050/33	–	
63	PVQA/8063/27	–	–	M/P40462	PVQM/8050/32	PVQA/8063/33	–	
80	PVQA/8080/27	–	–	M/P40463	PVQM/8080/32	PVQA/8080/33	–	
100	PVQA/8100/27	–	–	M/P40464	PVQM/8080/32	PVQA/8100/33	–	

Connectors

<p>Plug with cable gland</p>  <p>21</p> <p>V10027-D00 V10012-D13 (LED and VDR)</p>	<p>Plug with molded cable</p>  <p>22</p> <p>V10014-D01 (LED and VDR, cable length 1 m) V10014-D03 (LED and varistor, cable length 3 m)</p>	<p>Magnetically operated switches</p>  <p>25 Pages 12 & 13</p>
--	--	---

Service kit

<p>Service kit</p>  <p>Cyl. Ø Pages 12 & 13</p>	<p>32 PRQA/862032/00</p> <p>40 PRQA/862040/00</p> <p>50 PRQA/862050/00</p> <p>63 PRQA/862063/00</p> <p>80 PRQA/862080/00</p> <p>100 PRQA/862100/00</p>
--	--

P.A/862000/MG./213A/.; Cylinder with piston rod bellow

Dimensions in mm
Projection/First angle

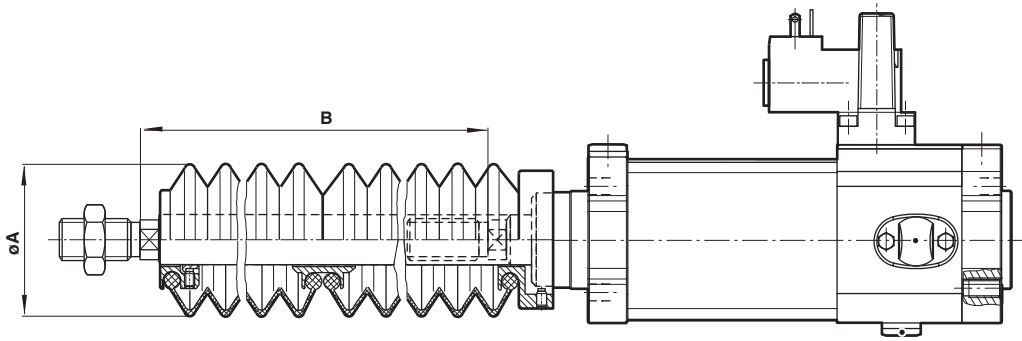

Cyl. \varnothing	$\varnothing A$	Stroke max per bellow	Piston rod extention B		Model
			for first bellow	for further bellows	
32	40	60	30	25	P#A/862032/MG+/213A/*
40	63	145	50	32	P#A/862040/MG+/213A/*
50	63	145	40	32	P#A/862050/MG+/213A/*
63	63	145	40	32	P#A/862063/MG+/213A/*
80	80	250	50	45	P#A/862080/MG+/213A/*
100	80	250	50	45	P#A/862100/MG+/213A/*

* Standard stroke length
Piston rod material
+ Valve function

Mountings

Front or rear stud mounting A

Conforms to ISO 1552, type MX1

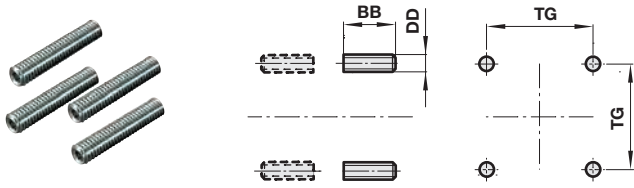

Standard

Ø	BB	DD	TG	kg	Model (A)
32/40	17	M6	32,5/38	0,02	QM/8032/35
50/63	23	M8	46,5/56,5	0,05	QM/8050/35
80/100	28	M10	72/89	0,08	QM/8080/35

Front flange B, G

Conforms to ISO 1552, type MF1 and MF2

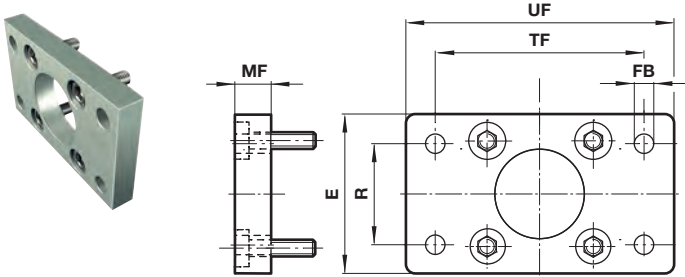

Standard

Ø	E	Ø FB	MF	R	TF	UF	kg	Model (B, G)
32	50	7	10	32	64	80	0,25	QA/8032/22
40	55	9	10	36	72	90	0,35	QA/8040/22
50	65	9	12	45	90	110	0,70	QA/8050/22
63	75	9	12	50	100	125	0,80	QA/8063/22
80	100	12	16	63	126	154	1,35	QA/8080/22
100	120	14	16	75	150	186	2,20	QA/8100/22

Corrosion protected version

32	50	7	10	32	64	80	0,25	PVQA/8032/22
40	55	9	10	36	72	90	0,35	PVQA/8040/22
50	65	9	12	45	90	110	0,7	PVQA/8050/22
63	75	9	12	50	100	125	0,8	PVQA/8063/22
80	100	12	16	63	126	154	1,35	PVQA/8080/22
100	120	14	16	75	150	186	2,2	PVQA/8100/22

Piston rod swivel AK

Dimensions in mm
Projection/First angle

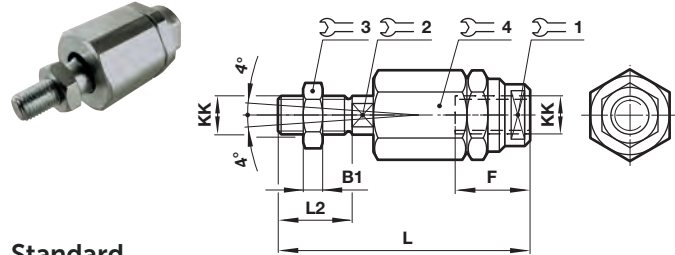

Standard

Ø	KK	B1	F	L	L2	1	2	3	4	kg	Model (AK)
32	M10x1,25	5	26	73	20	19	12	17	30	0,20	QM/8025/38
40	M12x1,25	6	26	77	24	19	12	19	30	0,20	QM/8040/38
50/63	M16x1,5	8	34	106	32	30	19	24	42	0,65	QM/8050/38
80/100	M20x1,5	10	42	122	40	30	19	30	42	0,72	QM/8080/38

Foot mounting C

Conforms to ISO 1552, type MS1

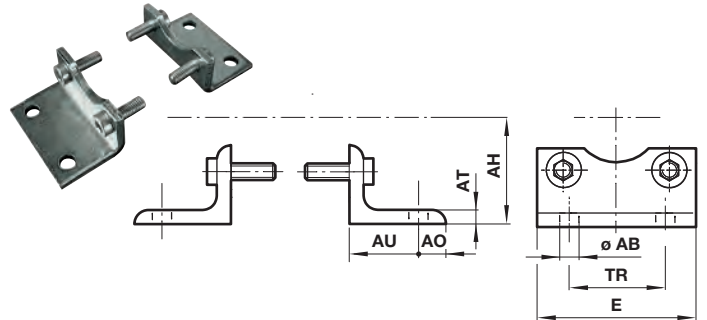

Standard

Ø	Ø AB	AH	AO	AT	AU	E	TR	kg	Model (C)
32	7	32	8	4	24	48	32	0,15	QA/8032/21
40	10	36	9	4	28	53	36	0,18	QA/8040/21
50	10	45	10	5	32	64	45	0,30	QA/8050/21
63	10	50	12	5	32	74	50	0,39	QA/8063/21
80	12	63	19	5	41	98	63	0,80	QA/8080/21
100	14	71	19	5	41	115	75	0,95	QA/8100/21

Rear clevis D
Conforms to ISO 15552, type MP2

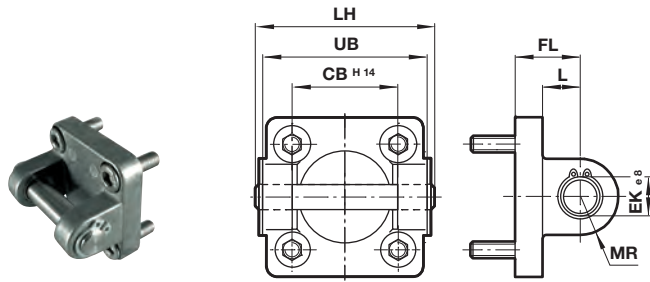

Standard

Ø	CB H14	Ø EK e8	FL	L	LH	MR	UB	kg	Model (D)
32	26	10	22	13	52	9	45	0,11	QA/8032/23
40	28	12	25	16	60	12	52	0,16	QA/8040/23
50	32	12	27	17	68	12	60	0,22	QA/8050/23
63	40	16	32	22	79	15	70	0,34	QA/8063/23
80	50	16	36	22	99	15	90	0,54	QA/8080/23
100	60	20	41	27	119	20	110	0,90	QA/8100/23
Corrosion protected version									
32	26	10	22	13	52	9	45	0,11	PVQA/8032/23
40	28	12	25	16	60	12	52	0,16	PVQA/8040/23
50	32	12	27	17	68	12	60	0,22	PVQA/8050/23
63	40	16	32	22	79	15	70	0,34	PVQA/8063/23
80	50	16	36	22	99	15	90	0,54	PVQA/8080/23
100	60	20	41	27	119	20	110	0,9	PVQA/8100/23

Rear clevis D2
Conforms to ISO 15552, type AB6

Dimensions in mm
Projection/First angle

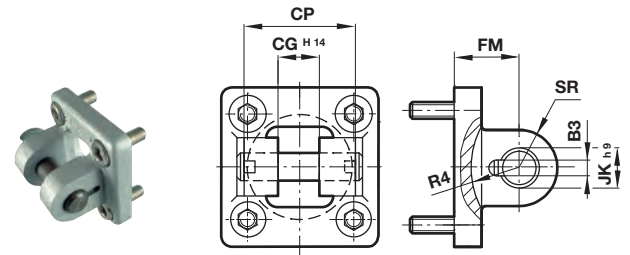

Standard

Ø	B1 H14	B2	B3	Ø EK h9	FL	R1	R2	kg	Model (D2)
32	14	34	3,3	10	22	11	17	0,20	QA/8032/42
40	16	40	4,3	12	25	12	20	0,23	QA/8040/42
50	21	45	4,3	16	27	14,5	22	0,36	QA/8050/42
63	21	51	4,3	16	32	18	25	0,55	QA/8063/42
80	25	65	4,3	20	36	22	30	0,90	QA/8080/42
100	25	75	4,3	20	41	22	32	1,45	QA/8100/42

Piston rod clevis F
Conforms to DIN ISO 8140

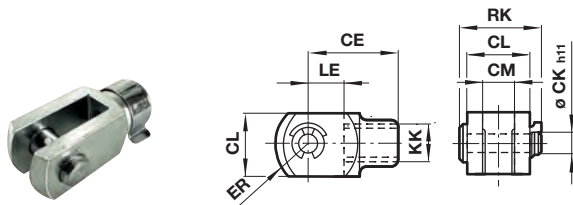

Standard

Ø	KK	CE	Ø CKh11	CL	CM	ER	LE	RK	kg	Model (F)
32	M10x1,25	40	10	20	10	16	20	28	0,09	QM/8025/25
40	M12x1,25	48	12	24	12	19	24	32	0,13	QM/8040/25
50/63	M16x1,5	64	16	32	16	25	32	41,5	0,33	QM/8050/25
80/100	M20x1,5	80	20	40	20	32	40	50	0,67	QM/8080/25
Corrosion protected version										
32	M10x1,25	40	10	20	10	16	20	28	0,09	PVQM/8032/25
40	M12x1,25	48	12	24	12	19	24	32	0,13	PVQM/8040/25
50/63	M16x1,5	64	16	32	16	25	32	41,5	0,33	PVQM/8050/25
80/100	M20x1,5	80	20	40	20	32	40	50	0,67	PVQM/8080/25

Front or rear detachable trunnion FH
Conforms to VDMA 24562 part 2,
type MT 5/6

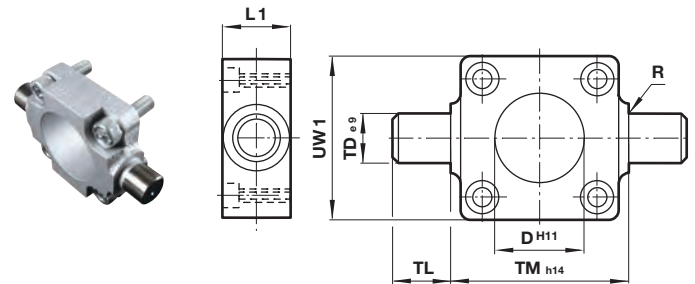

Standard

Ø	Ø D h11	L1	R	Ø TD e9	TL	TM h14	UW1	kg	Model (FH)
32	30	16	1	12	12	50	45	0,20	QA/8032/34
40	35	20	1,6	16	16	63	55	0,38	QA/8040/34
50	40	24	1,6	16	16	75	65	0,60	QA/8050/34
63	45	24	1,6	20	20	90	75	1,10	QA/8063/34
80	45	28	1,6	20	20	110	100	1,90	QA/8080/34
100	55	38	2	25	25	132	120	3,50	QA/8100/34

Rear eye R
Conforms to ISO 15552, type MP4

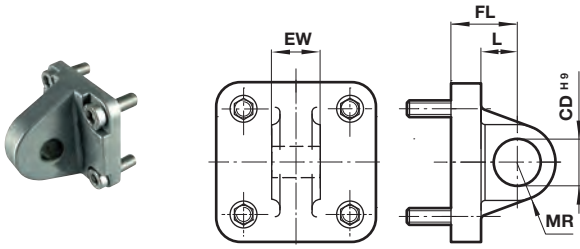

Trunnion support S
Conforms to ISO 15552, type AT4

Dimensions in mm
Projection/First angle

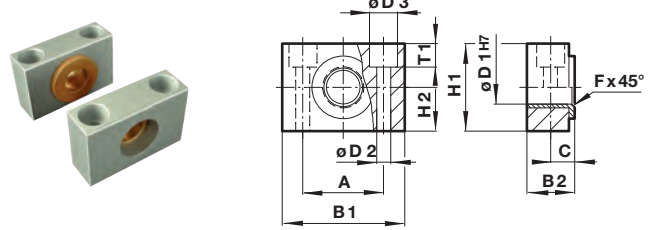

Standard

Ø	Ø CD H9	EW	FL	L	MR	kg	Model (R)
32	10	25,8	22	13	9	0,09	QA/8032/27
40	12	27,8	25	16	12	0,11	QA/8040/27
50	12	31,7	27	17	12	0,17	QA/8050/27
63	16	39,7	32	22	15	0,24	QA/8063/27
80	16	49,7	36	22	15	0,37	QA/8080/27
100	20	59,7	41	27	20	0,59	QA/8100/27
Corrosion protected version							
32	10	25,8	22	13	9	0,09	PVQA/8032/27
40	12	27,8	25	16	12	0,11	PVQA/8040/27
50	12	31,7	27	17	12	0,17	PVQA/8050/27
63	16	39,7	32	22	15	0,24	PVQA/8063/27
80	16	49,7	36	22	15	0,37	PVQA/8080/27
100	20	59,7	41	27	20	0,59	PVQA/8100/27

Standard

Ø	A	B	C	Ø D1H7	Ø D2	Ø D3	Fx 45°	H	T1	kg	Model (S)		
32	32	46	18	10,5	12	6,6	11	1	30	15	6,8	0,10	QA/8032/41
40/50	36	55	21	12	16	9	15	1,6	36	18	9	0,14	QA/8040/41
63/80	42	65	23	13	20	11	18	1,6	40	20	11	0,18	QA/8063/41
100	50	75	28,5	16	25	14	20	2	50	25	13	0,34	QA/8100/41

Universal piston rod eye UF
Conforms to DIN ISO 8139

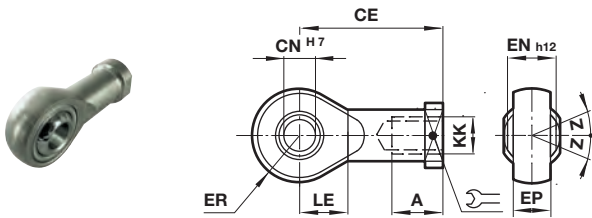

Wide hinge SW
Conforms to ISO 15552, type AB7

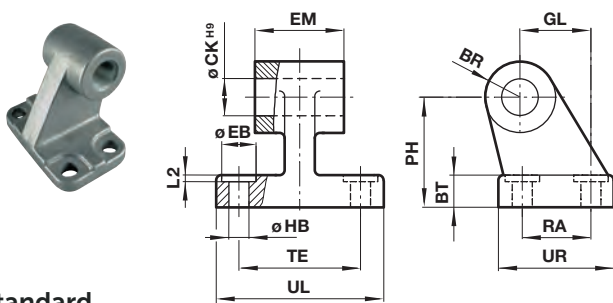

Standard

Ø	Thread KK	AX	CE	Ø CN H7	EN -0,1	ER	LE	Z	kg	Model (UF)
32	M10x1,25	20	43	10	14	14	15	13°	0,09	QM/8025/32
40	M12x1,25	22	50	12	16	16	17	13°	0,13	QM/8040/32
50/63	M16x1,5	28	64	16	21	21	22	15°	0,33	QM/8050/32
80/100	M20x1,5	33	77	20	25	25	26	15°	0,67	QM/8080/32
Corrosion protected version										
32	M10x1,25	20	43	10	14	14	15	13°	0,09	PVQM/8025/32
40	M12x1,25	22	50	12	16	16	17	13°	0,13	PVQM/8040/32
50/63	M16x1,5	28	64	16	21	21	22	15°	0,33	PVQM/8050/32
80/100	M20x1,5	33	77	20	25	25	26	15°	0,4	PVQM/8080/32

Standard

Ø	CA	Ø CKH9	D	H	EM	G	G	G	K	K	L	R	Ø S	kg	Model (SW)
32	32	10	11	7	25,5	21	18	31	38	50	1,6	10	6,6	0,05	M/P19493
40	36	12	11	9	27,5	24	22	35	41	54	1,6	11	6,6	0,07	M/P19494
50	45	12	15	11	31,5	33	30	45	50	65	1,6	13	9	0,14	M/P19495
63	50	16	15	12	39,5	37	35	50	52	67	1,6	15	9	0,18	M/P19496
80	63	16	18	14	49,5	47	40	60	66	84	2,5	15	11	0,28	M/P19497
100	71	20	18	15	59,5	55	50	70	76	94	2,5	19	11	0,42	M/P19498
Corrosion protected version															
32	32	10	11	8	26,5	21	18	31	38	51	1,6	10	6,6	0,05	M/P40459
40	36	12	11	10	28,5	24	22	35	41	54	1,6	11	6,6	0,07	M/P40460
50	45	12	15	12	32,5	33	30	45	50	65	1,6	13	9	0,14	M/P40461
63	50	16	15	12	40,5	37	35	50	52	67	1,6	15	9	0,18	M/P40462
80	63	16	18	14	50,5	47	40	60	66	86	2,5	15	11	0,28	M/P40463
100	71	20	18	15	60,5	55	50	70	76	96	2,5	19	11	0,42	M/P40464

Universal rear eye UR
Conforms to ISO 15552, type MP6

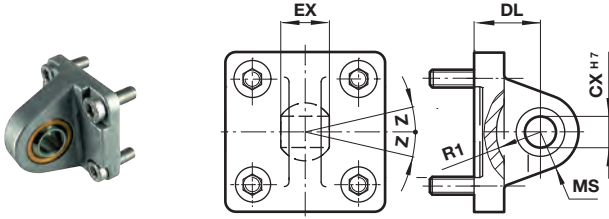

Narrow hinge SS

Dimensions in mm
Projection/First angle

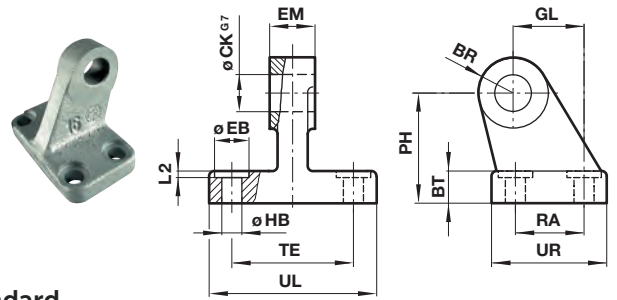

Standard

Ø	Ø CN H7	EN	ER	FL	R	Z	kg	Model (UR)
32	10	14	16	22	14,5	13°	0,15	QA/8032/33
40	12	16	18	25	18	13°	0,25	QA/8040/33
50	16	21	21	27	19	15°	0,40	QA/8050/33
63	16	21	23	32	24	15°	0,55	QA/8063/33
80	20	25	28	36	24	15°	0,90	QA/8080/33
100	20	25	30	41	29	15°	1,50	QA/8100/33
Corrosion protected version								
32	10	14	16	22	14,5	13°	0,15	PVQA/8032/33
40	12	16	19	25	18	13°	0,25	PVQA/8040/33
50	16	21	21	27	19	13°	0,4	PVQA/8050/33
63	16	21	24	32	24	15°	0,55	PVQA/8063/33
80	20	25	28	36	24	15°	0,9	PVQA/8080/33
100	20	25	30	41	29	15°	1,5	PVQA/8100/33

Standard

Ø	CA	Ø CNG7	Ø D	H 2	EM	G 1	G 2	G 3	K 1	K 2	L 1	R	Ø S	kg	Model (SS)
32	32	10	11	8	10	21	18	31	38	51	1,6	10	6,6	0,15	M/P19931
40	36	12	11	10	12	24	22	35	41	54	1,6	11	6,6	0,20	M/P19932
50	45	16	15	12	16	33	30	45	50	65	1,6	13	9	0,48	M/P19933
63	50	16	15	12	16	37	35	50	52	67	1,6	15	9	0,50	M/P19934
80	63	20	18	14	20	47	40	60	66	86	2,5	15	11	0,75	M/P19935
100	71	20	18	15	20	55	50	70	76	96	2,5	19	11	1,20	M/P19936

Swivel hinge US
Conforms to VDMA 24562 part 2

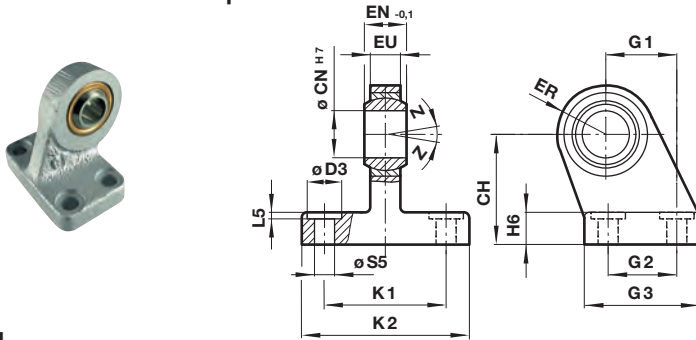

Standard

Ø	CH	Ø CN H7	Ø D	EN -0,1	ER	EU	G1	G2	G3	H2	K1	K2	L1	Ø S	Z	kg	Model (US)
32	32	10	11	14	16	10,5	21	18	31	10	38	51	1,6	6,6	13°	0,19	M/P40310
40	36	12	11	16	18	12	24	22	35	10	41	54	1,6	6,6	13°	0,24	M/P40311
50	45	16	15	21	21	15	33	30	45	12	50	65	1,6	9	13°	0,46	M/P40312
63	50	16	15	21	23	15	37	35	50	12	52	67	1,6	9	15°	0,59	M/P40313
80	63	20	18	25	28	18	47	40	60	14	66	86	2,5	11	15°	1,03	M/P40314
100	71	20	18	25	30	18	55	50	70	15	76	96	2,5	11	15°	1,40	M/P40315

Technical data - Reed switches - additional informations see data sheet 4.3.005

Symbol	Voltage		Current maximum (mA)	Function	Temperature (°C)	LED	Protection class	Plug	Cable length (m)	Cable type	Weight (g)	Model
	(V a.c.)	(V d.c.)										
	10 ... 240	10 ... 170	180	Closer	-25 ... +80	•	IP66	—	2, 5 or 10	PVC 2 x 0,25	37	M/50/LSU/*V
	10 ... 240	10 ... 170	180	Closer	-25 ... +80	•	IP66	—	5	PUR 2 x 0,25	37	M/50/LSU/5U
	10 ... 240	10 ... 170	180	Closer	-25 ... +150	—	IP66	—	2	Silicon 2 x 0,25	37	TM/50/RAU/2S
	10 ... 240	10 ... 170	180	Changeover	-25 ... +80	—	IP66	—	5	PVC 3 x 0,25	37	M/50/RAC/5V
	10 ... 60	10 ... 60	180	Closer	-25 ... +80	•	IP66	M8 x 1	0,3	PVC 3 x 0,25	16	M/50/LSU/CP *1)

* Insert cable length; *1) Plug-in connector see page 11; Color code: BK = black, BN = brown, BU = blue

Drawings

M/50/LSU/*V, M/50/LSU/5U,
TM/50/RAU/2S
Cable length L = 2, 5 or 10 m

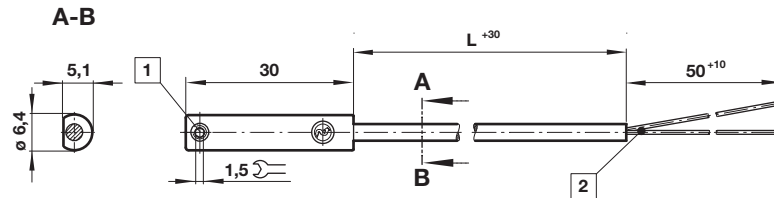

Dimensions in mm
Projection/First angle



M/50/RAC/5V
Cable length L = 5 m

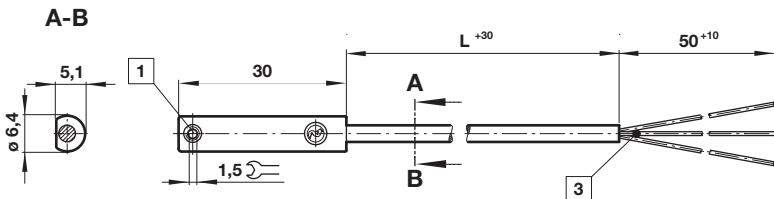

M/50/LSU/CP

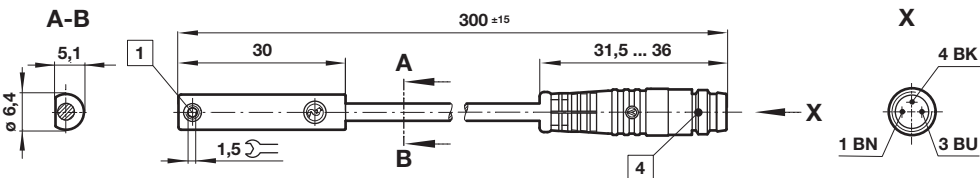

- 1 Fixing screw
- 2 + BN = brown; - BU = blue (output)
- 3 - BK = black; + BN = brown; - BU = blue
- 4 Plug M8 x 1, color code: BK = black; BN = brown; BU = blue

Accessories

Plug-in connector cable with nut				
Outer cover	Cable length (m)	Weight (kg)	Connector	Connector
PVC 3 x 0,25	5 m	0,18	M8 x 1	M/P73001/5
PUR 3 x 0,25	5 m	0,18	M8 x 1	M/P73002/5
PUR 3 x 0,34	5 m	0,21	M12 x 1	M/P34594/5

Technical data - Solid state - additional informations see data sheet 4.3.007

Symbol	Voltage (V d.c.)	Current maximum (mA)	Function	Temperature (°C)	LED	Protection class	Plug	Cable length (m)	Cable type	Weight (g)	Model
	10 ... 30	150	PNP	-40 ... +80	•	IP67	—	2, 5 or 10	PVC 3 x 0,12	37	M/50/EAP/*V
	10 ... 30	150	PNP	-40 ... +80	•	IP68	—	5	PUR 3 x 0,14	37	M/50/EAP/5U
	10 ... 30	150	PNP	-40 ... +80	•	IP67	M8 x 1	0,3	PVC 3 x 0,14	16	M/50/EAP/CP *1)
	10 ... 30	150	PNP	-40 ... +80	•	IP67	M12 x 1	0,3	PVC 3 x 0,14	16	M/50/EAP/CC *1)
	10 ... 30	150	NPN	-40 ... +80	•	IP67	—	2, 5 or 10	PVC 3 x 0,12	37	M/50/EAN/*V
	10 ... 30	150	Closer	-40 ... +80	•	IP67	M8 x 1	0,3	PVC 3 x 0,14	16	M/50/EAN/CP *1)

* Insert cable length; *1) Plug-in connector below; Color code: BK = black, BN = brown, BU = blue

Drawings

M/50/EAP/*V,
M/50/EAN/*V
Cable length L = 2, 5 or 10 m

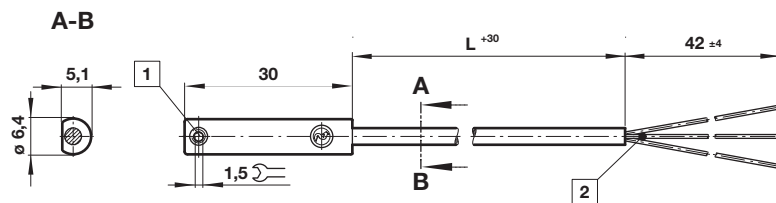

Dimensions in mm
Projection/First angle



M/50/EAP/CP,
M/50/EAN/CP

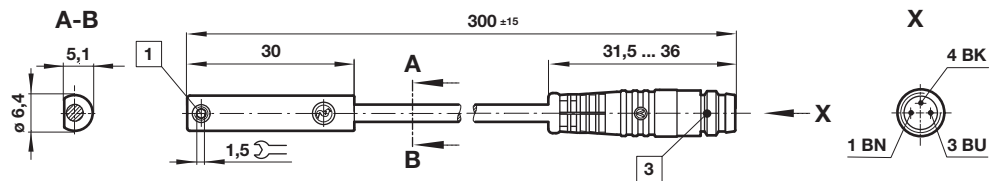

M/50/EAP/CC

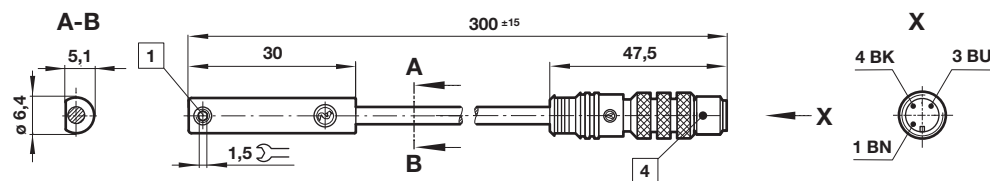

- 1 Fixing screw
- 2 Color code: BK = black; BN = brown; BU = blue
- 3 Plug M8 x 1
- 4 Plug M12 x 1

Warning

These products are intended for use in industrial compressed air systems only. Do not use these products where pressures and temperatures can exceed those listed under

»Technical features/data«.

Before using these products with fluids other than those specified, for non-industrial applications, life-support systems or other applications not within published specifications, consult IMI Precision Engineering, Norgren GmbH.

Through misuse, age, or malfunction, components used in fluid power systems can fail in various modes.

The system designer is warned to consider the failure modes of all component parts used in fluid power systems and to provide adequate safeguards to prevent personal injury or damage to equipment in the event of such failure.

System designers must provide a warning to end users in the system instructional manual if protection against a failure mode cannot be adequately provided.

System designers and end users are cautioned to review specific warnings found in instruction sheets packed and shipped with these products.