

M/60285 ... M/60288

Rotary vane actuators, double acting

- Torque at 6 bar
5,78 ... 241,73 Nm
- High torque from compact units
- Rotation angles from
90 ... 270°
- Suitable for torques
from 1,23 ... 402,46 Nm



Technical features

Medium:

Compressed air, filtered, lubricated or non-lubricated

Operation:

Double acting rotary vane with buffer cushioning
M/60285 to M/60288 single vane
M/60285/TI to M/60288/TI double vane

Operating pressure:

2 ... 10 bar (29 ... 145 psi)

Rotation angle:

90°, 180°, 270° single vane
90° double vane

Rotation tolerance:

0 ... +3°

Other features:

Featherkey supplied as standard

Operating temperature:

-5°C ... +60°C (+23 ... +140°F)
Air supply must be dry enough to avoid ice formation at temperatures below +2°C (+35°F)

Materials:

Body: Cast aluminium
Shaft: Steel
Shaft bearing: Sintered bronze
Seals: NBR

Technical data, standard

Port size	Theoretical torque at 6 bar (Nm)	Permissible forces *1)		Permissible rotation energy *2) (Nm)	Maximum frequency *3)			Air consumption			Weight			Model
		axial (N)	radial (N)		90°	180°	270°	90°	180°	270°	90°	180°	270°	
G 1/8	5,8	44,1	588	49 x 10 ⁻³	180	90	60	51	51	61	0,82	0,79	0,73	M/60285
G1/8	12,8				180			42			0,82			M/60285/TI
G1/4	18	88,2	1176	225,4 x 10 ⁻³	120	78	48	146	146	179	2	1,9	1,7	M/60286
G1/4	41,5				120			127			2			M/60286/TI
G3/8	34,5	147	1960	1078 x 10 ⁻³	90	60	42	244	283	352	3,7	3,7	3,7	M/60287
G3/8	83				90			244			4,3			M/60287/TI
G1/2	123	490	4900	3920 x 10 ⁻³	66	45	30	754	869	1036	12,7	12,2	11,2	M/60288
G1/2	247				66			754			12,7			M/60288/TI

*1) Permissible load on rotary vane shaft

*2) Permissible rotational energy in Nm which may be applied to shaft. It can be calculated as follows:
Permissible rotational energy $\geq 1/2 IXX2 \cdot l$, I = Angular moment, XX= Mean angular velocity

*3) Maximum frequency at 5 bar pressure, no load

Hydro-cushion

Min. operating pressure (bar)	Operating temperature (C°)	Load range (kg x cm2)	Max. absorption energy (Nm)	Max. absorption energy per minute (Nm/min)	Absorbing angle (°)	Maximum collision angular velocity (°/s)	Weight (kg)	Model
3	+5 ... +50	981	2,9	20	11	850	0,24	QM/60285/60
3	+5 ... +50	2942	9,8	71	12	750	0,42	QM/60286/60
3	+5 ... +50	5884	19,6	137	14	650	0,78	QM/60287/60

Mini rotary vane actuators models with fixed or adjustable rotation angles

Rotation angle			Double vane	Single vane	Model
90°	180°	270°			
•	•	•		•	M/60285/*
•			•		M/60285/TI
•	•	•		•	M/60286/*
•			•		M/60286/TI
•	•			•	M/60287/*
•			•		M/60287/TI
•	•	•		•	M/60288/*
•			•		M/60288/TI
•			•		M/60284/TI

Option selector

M/6028★/★★/★★★

Size	Substitute
5, 6, 7, 8	X

Rotation	Substitute
Standard only	see table
Variants	Substitute
Single vane, fixed	None
Double vane, fixed	Tl

Note: Please fill in only the numbers of digits required. Please order the mounting kit and hydro-cushion kit separately.

Mountings

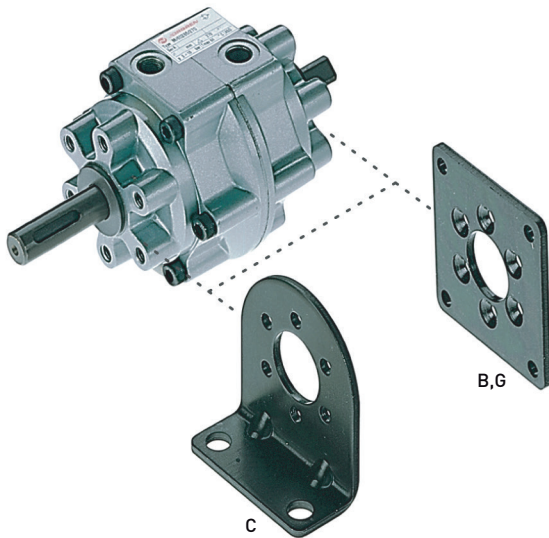

Model	B, G	C	Adaptor for Switches
	Page 4	Page 4	Page 4
M/60285, .../TI	QM/60285/22	QM/60285/21	M/P72487
M/60286, .../TI	QM/60286/22	QM/60286/21	M/P72487
M/60287, .../TI	-	QM/60287/21	M/P72487
M/60288, .../TI	-	QM/60288/21	M/P72487

Basic dimensions

Dimensions in mm
Projection/First angle

Rotation start point

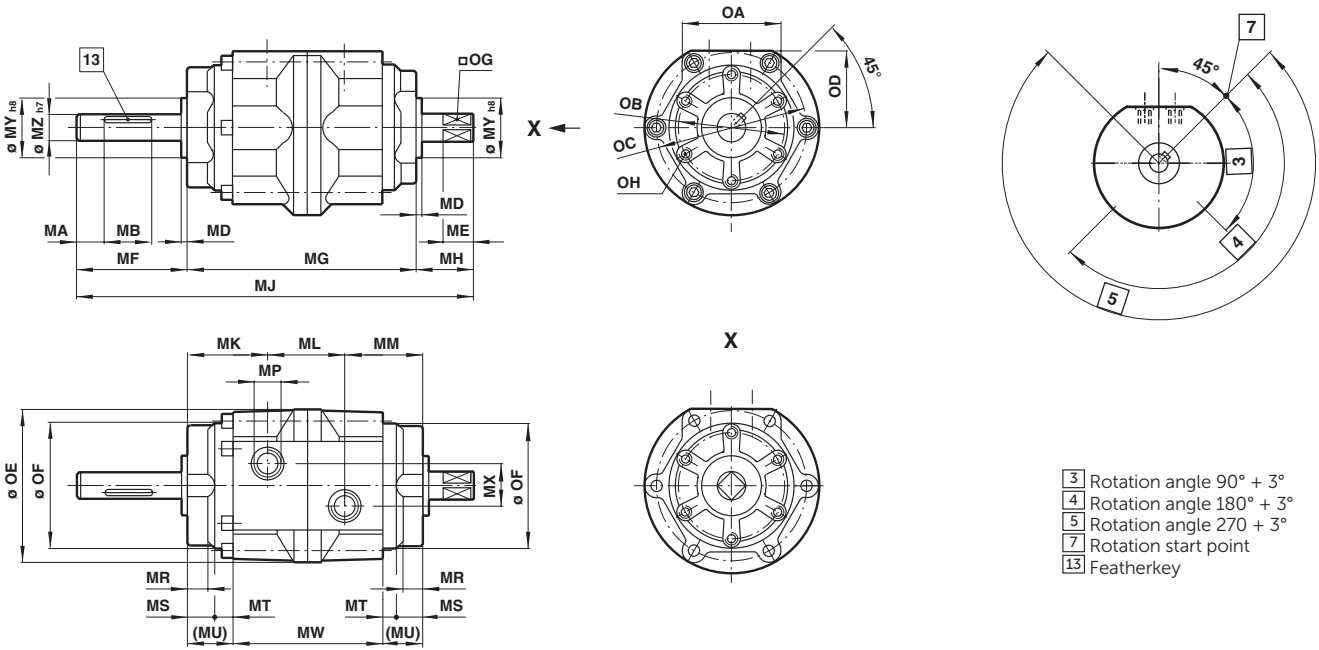

- 3 Rotation angle 90° + 3°
- 4 Rotation angle 180° + 3°
- 5 Rotation angle 270° + 3°
- 7 Rotation start point
- 13 Featherkey

MA	MB	MD	ME	MF	MG	MH	MJ	MK	ML	MM	MP	MR	MS	MT	MU	Model
5	20	2,5	13	39,5	86	19,5	145	29	28	29	G1/8	11	14	6	20	M/60285/ .../TI
5	36	3	16	53,5	103	23,5	180	34,5	34	34,5	G1/4	10,5	15,5	8	23,5	M/60286/ .../TI
5	40	3,5	22	65	125	30	220	41,5	4	41,5	G3/8	13	17,5	10	27,5	M/60287/ .../TI
10	40	4,5	35	69,5	171	44,5	285	53,5	64	53,5	G1/2	14,5	21	11,5	32,5	M/60288/ .../TI
MW	MX	Ø MYh8	Ø MZ h7	OA	Ø OB	Ø OC	OD	Ø OE	Ø OF	OG -0,1	OH	Featherkey	(kg)	Model		
46	16	25	12	44	45	68	36	79	58	10	M6 x 9*1)	4 -0,03 x 2,5 + 0,1*1)	0,82	M/60285/ .../TI		
56	24	30	17	61	70	97	51	110	85,5	13	M8 x 12*1)	5 -0,03 x 3 + 0,1*1)	2	M/60286/ .../TI		
70	32	45	25	78	80	125	66	141,5	110	19	M10 x 15*1)	7 -0,038 x 4 + 0,2*1)	4,3	M/60287/ .../TI		
106	44	70	40	110	120	173	90	196	152	32	M12 x 18*1)	12 -0,043 x 5 + 0,2*1)	12,7	M/60288/ .../TI		

Mountings Foot C

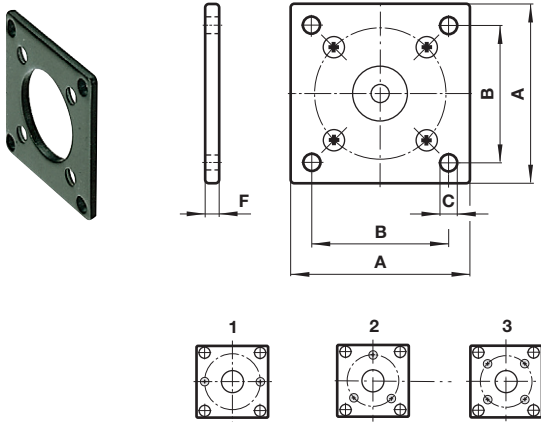

Rear flange B, Front flange G

Dimensions in mm
Projection/First angle

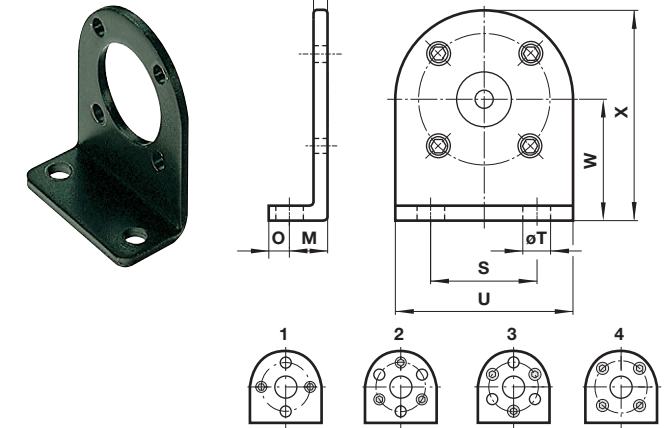

A	B	ϕC	E	Rotation angle *2)	(kg)	Model
80	64	7	4,5	60°	0,2	QM/60285/22
110	88	9	6	60°	0,51	QM/60286/22

K	M	O	S	ϕT	U	W	X	Rotation angle *2)	(kg)	Model
4,5	25	10	55	11	75	45	82,5	60°	0,26	QM/60285/21
10	28	12	80	13	110	65	115	60°	1,14	QM/60286/21
12	32	13	100	15	140	80	135	60°	1,24	QM/60287/21
15	35	15	140	15	200	110	200	60°	4,45	QM/60288/21

Hydro-cushion kit

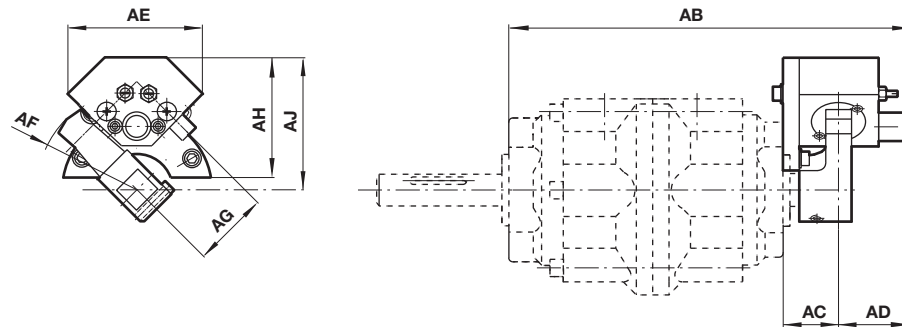

AB	AC	AD	AE	AF	AG	AH	AJ	Model
136,5	20,5	30	56	38	34	50	54	QM/60285/60
159,5	22,5	34	80	51	46	62	71,5	QM/60286/60
187,5	25,5	37	95	68	62	87	96	QM/60287/60

Brackets for switches M/50

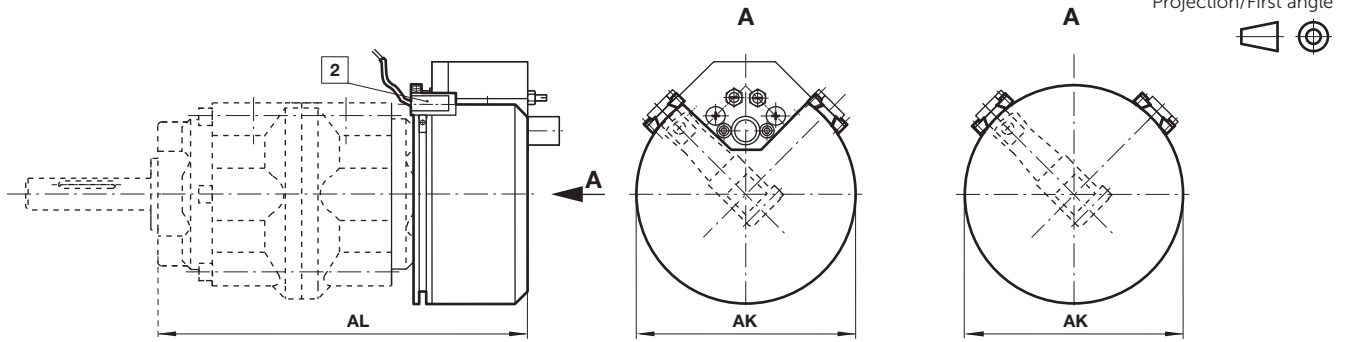

2 Switch

ø AK	AL	Brackets for 2 switches without hydro-cushion	Brackets for 2 switches with hydro-cushion
85	123	QM/60285/22/64	QM/60285/23/64
111	143	QM/60286/22/64	QM/60286/23/64
145	169	QM/60287/22/64	QM/60287/23/64

Claw (for hydro-cushion and magnetic sensing)

Rotation start point

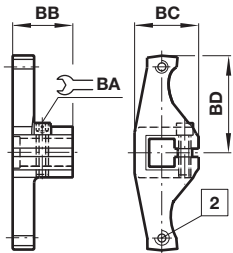

Rotation start point

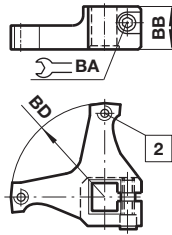

Rotation start point

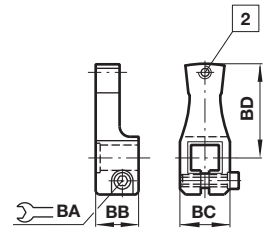

2 M4 (6 mm deep)

Model	Actuator	BA	BB	BC	BD
M/P70088 (90°), M/P70089 (180°), M/P70090 (270°)	M/60285	4	18	23	38
M/P70091 (90°), M/P70092 (180°), M/P70093 (270°)	M/60286	5	20	28	51
M/P70094 (90°), M/P70095 (180°), M/P70096 (270°)	M/60287	6	23,5	40	68

Technical data - Reed switches - additional informations see data sheet N/en 4.3.005

Symbol	Voltage		Current maximum (mA)	Function	Temperature (°C)	LED	Protection class	Plug	Cable length (m)	Cable type	Weight (g)	Model
	(V a.c.)	(V d.c.)										
	10 ... 240	10 ... 170	180	Closer	-25 ... +80	•	IP66	—	2, 5 or 10	PVC 2 x 0,25	37	M/50/LSU/*V
	10 ... 240	10 ... 170	180	Closer	-25 ... +80	•	IP66	—	5	PUR 2 x 0,25	37	M/50/LSU/5U
	10 ... 240	10 ... 170	180	Closer	-25 ... +150	—	IP66	—	2	Silicon 2 x 0,25	37	TM/50/RAU/2S
	10 ... 240	10 ... 170	180	Changeover	-25 ... +80	—	IP66	—	5	PVC 3 x 0,25	37	M/50/RAC/5V
	10 ... 60	10 ... 60	180	Closer	-25 ... +80	•	IP66	M8 x 1	0,3	PVC 3 x 0,25	16	M/50/LSU/CP *1)

* Insert cable length; *1) Plug-in connector Color code: BK = black, BN = brown, BU = blue

Drawings

M/50/LSU/*V, M/50/LSU/5U,
TM/50/RAU/2S
Cable length L = 2, 5 or 10 m



M/50/RAC/5V
Cable length L = 5 m



M/50/LSU/CP

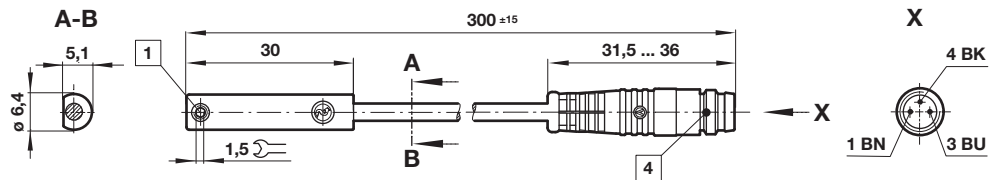
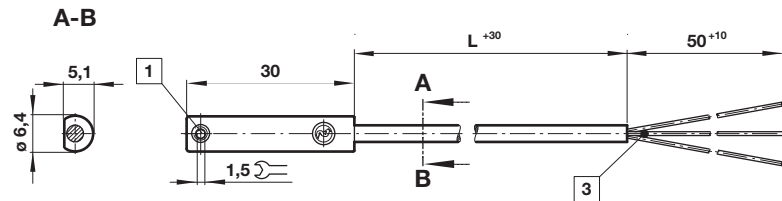
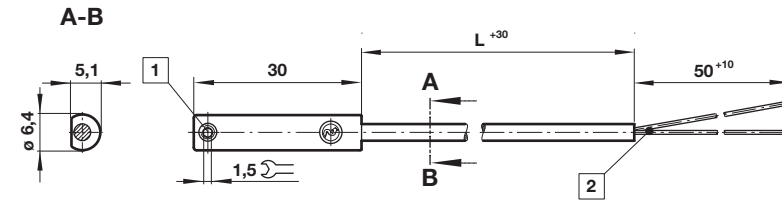

Dimensions in mm
Projection/First angle



- 1 Fixing screw
- 2 + BN = brown; - BU = blue (output)
- 3 - BK = black; + BN = brown; - ≠BU = blue
- 4 Plug M8 x 1, color code: BK = black; BN = brown; BU = blue

Accessories

Plug-in connector cable with nut				
Outer cover	Cable length (m)	Weight (kg)	Connector	Connector
PVC 3 x 0,25	5 m	0,18	M8 x 1	M/P73001/5
PUR 3 x 0,25	5 m	0,18	M8 x 1	M/P73002/5
PUR 3 x 0,34	5 m	0,21	M12 x 1	M/P34594/5



Technical data - Solid state - additional informations see data sheet N/en 4.3.007

Symbol	Voltage (V d.c.)	Current maximum (mA)	Temperature (°C)	LED	Protection class	Plug	Cable length (m)	Cable type	Weight (g)	Model	
	10 ... 30	150	PNP	-40 ... +80	•	IP67	—	2, 5 or 10	PVC 3 x 0,12	37	M/50/EAP/*V
	10 ... 30	150	PNP	-40 ... +80	•	IP68	—	5	PUR 3 x 0,14	37	M/50/EAP/5U
	10 ... 30	150	PNP	-40 ... +80	•	IP67	M8 x 1	0,3	PVC 3 x 0,14	16	M/50/EAP/CP *1)
	10 ... 30	150	PNP	-40 ... +80	•	IP67	M12 x 1	0,3	PVC 3 x 0,14	16	M/50/EAP/CC *1)
	10 ... 30	150	NPN	-40 ... +80	•	IP67	—	2, 5 or 10	PVC 3 x 0,12	37	M/50/EAN/*V
	10 ... 30	150	Closer	-40 ... +80	•	IP67	M8 x 1	0,3	PVC 3 x 0,14	16	M/50/EAN/CP *1)

* Insert cable length; *1) Plug-in connector; Color code: BK = black, BN = brown, BU = blue

Drawings

M/50/EAP/*V,
M/50/EAN/*V
Cable length L = 2, 5 or 10 m

Dimensions in mm
Projection/First angle

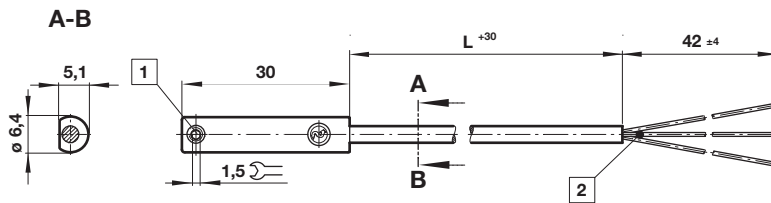

M/50/EAP/CP,
M/50/EAN/CP

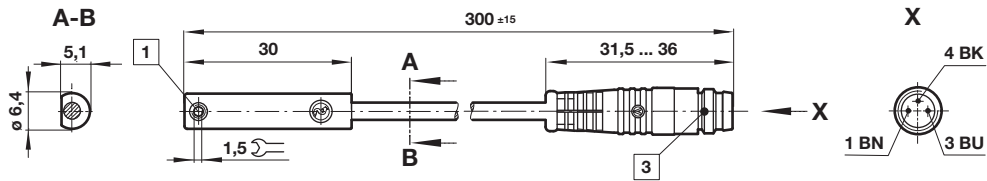

M/50/EAP/CC

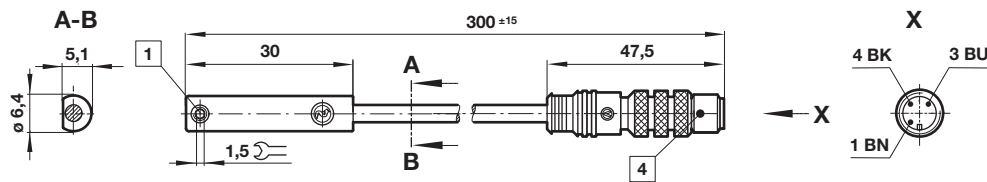

- 1) Fixing screw
- 2) Color code: BK = black; BN = brown; BU = blue
- 3) Plug M8 x 1
- 4) Plug M12 x 1

Warning

These products are intended for use in industrial compressed air systems only. Do not use these products where pressures and temperatures can exceed those listed under »**Technical features/ data**«.

Before using these products with fluids other than those specified, for non-industrial applications, life-support systems or other applications not within published specifications, consult Norgren GmbH.

Through misuse, age, or malfunction, components used in fluid power systems can fail in various modes.

The system designer is warned to consider the failure modes of all component parts used in fluid power systems and to provide adequate safeguards to prevent personal injury or damage to equipment in the event of such failure.

System designers must provide a warning to end users in the system instructional manual if protection against a failure mode cannot be adequately provided.

System designers and end users are cautioned to review specific warnings found in instruction sheets packed and shipped with these products.