

**Ideal for general purpose gripping applications**  
**Smooth, accurate movement**  
**Long, uninterrupted service life**  
**Low weight**  
**Compact size**  
**Integral magnets for positional feedback**

**Technical data**

**Medium:**  
 Compressed air, filtered, lubricated or non-lubricated  
**Operation:**  
 Single acting, parallel, magnetic piston  
**Operating pressure:**  
 2,5 to 7 bar  
 (Ø 10 mm 3,5 to 7 bar)  
**Operating temperature:**  
 0°C to +60°C  
 \* Air supply must be dry enough to avoid ice formation at temperatures below +2°C

**Mounting:**

Mounting holes on three faces

**Gripping repeatability:**  
 +/- 0,01 mm

**Mechanical life:**  
 ~ 5 million cycles before maintenance may be necessary

**Operating frequency:**  
 200 cycles per minute maximum

**Materials**

Body: aluminium alloy  
 Top plate: carbon steel  
 Fingers: carbon steel  
 External screws: carbon steel  
 Elastomers: nitrile

**Ordering information**

To order a gripper with an effective closing grip force of up to 21 N at 5 bar quote:  
**M/160344/M/11**

Order magnetically operated switches separately

**Accessories**

Switch M/344

See page

2

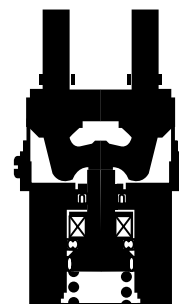
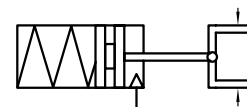



**Standard models • Effective gripping force • Air consumption**

Model	Effective gripping force (N) at 5 bar*		Air consumption (cm <sup>3</sup> ) at 5 bar**
	Opening	Closing	
M/160343/M/11	2	4,9	0,1
M/160344/M/11	3,9	21	0,65
M/160345/M/11	6,9	36,4	1,4
M/160346/M/11	13,7	54	2,8

\* Grip point L = 30 mm

\*\* per cycle

**Theoretical closing gripping forces**

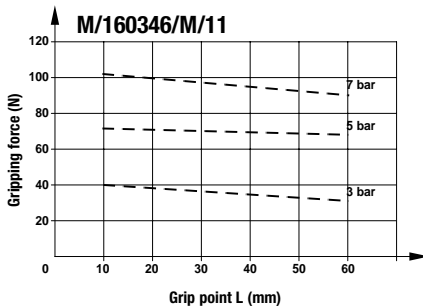
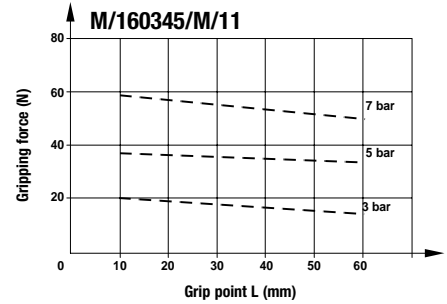
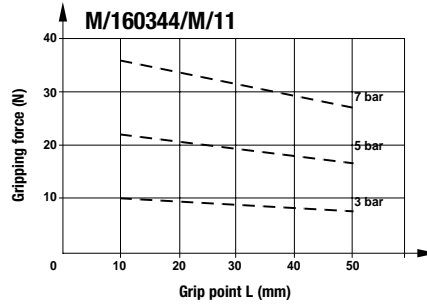
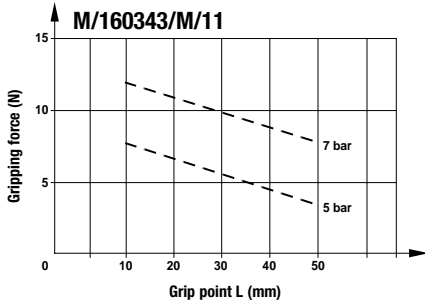

Workpiece grip point

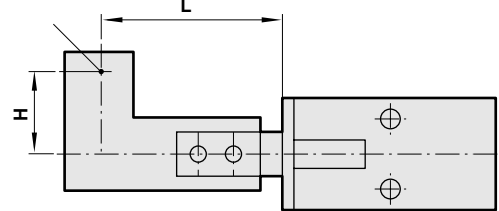

Effective closing gripping forces = Theoretical closing gripping force x 0,85

**Grip point limitation range**

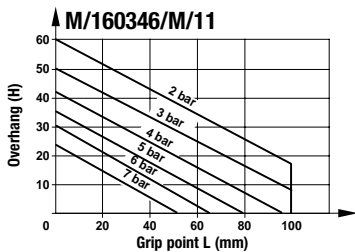
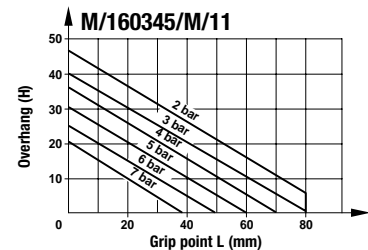
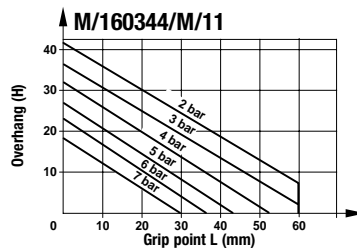
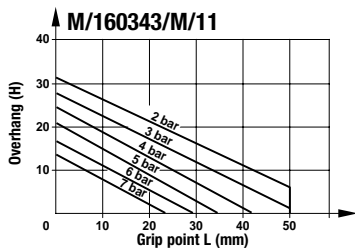

**Criteria of workpiece weight**

When chucking a workpiece, weight should be within the range between 1/10 and 1/20 of the above gripping force.

When chucking and then moving a workpiece, the workpiece may protrude or drop. Therefore, workpiece weight should be less than the above mentioned value. (Reference value is 1/30-1/50)

Weight depends on the operational condition, such as material and shape of workpiece or claw, speed and direction of moving workpiece (straight advance, rotation or swing, etc.)

**Switches with LED indication**

Model	2-wire solid state	3-wire solid state	Voltage V d.c.	Current max.	Temperature °C	LED	Features	Cable length	Cable type	Straight cable connection	90° elbow cable connection
M/344/EAU/1APV			10 ... 28	20 mA	0° ... +60°	●	–	1 m	PVC	–	●
M/344/EAU/1PV			10 ... 28	20 mA	0° ... +60°	●	–	1 m	PVC	●	–
M/344/EAU/3APV			10 ... 28	20 mA	0° ... +60°	●	–	3 m	PVC	–	●
M/344/EAU/3PV			10 ... 28	20 mA	0° ... +60°	●	–	3 m	PVC	●	–
		M/344/EAN/1APV	4,5 ... 28	50 mA	0° ... +60°	●	NPN	1 m	PVC	–	●
		M/344/EAN/1PV	4,5 ... 28	50 mA	0° ... +60°	●	NPN	1 m	PVC	●	–
		M/344/EAN/3APV	4,5 ... 28	50 mA	0° ... +60°	●	NPN	3 m	PVC	–	●
		M/344/EAN/3PV	4,5 ... 28	50 mA	0° ... +60°	●	NPN	3 m	PVC	●	–
		M/344/EAP/1APV	4,5 ... 28	50 mA	0° ... +60°	●	PNP	1 m	PVC	–	●
		M/344/EAP/1PV	4,5 ... 28	50 mA	0° ... +60°	●	PNP	1 m	PVC	●	–
		M/344/EAP/3APV	4,5 ... 28	50 mA	0° ... +60°	●	PNP	3 m	PVC	–	●
		M/344/EAP/3PV	4,5 ... 28	50 mA	0° ... +60°	●	PNP	3 m	PVC	●	–



## Dimensions

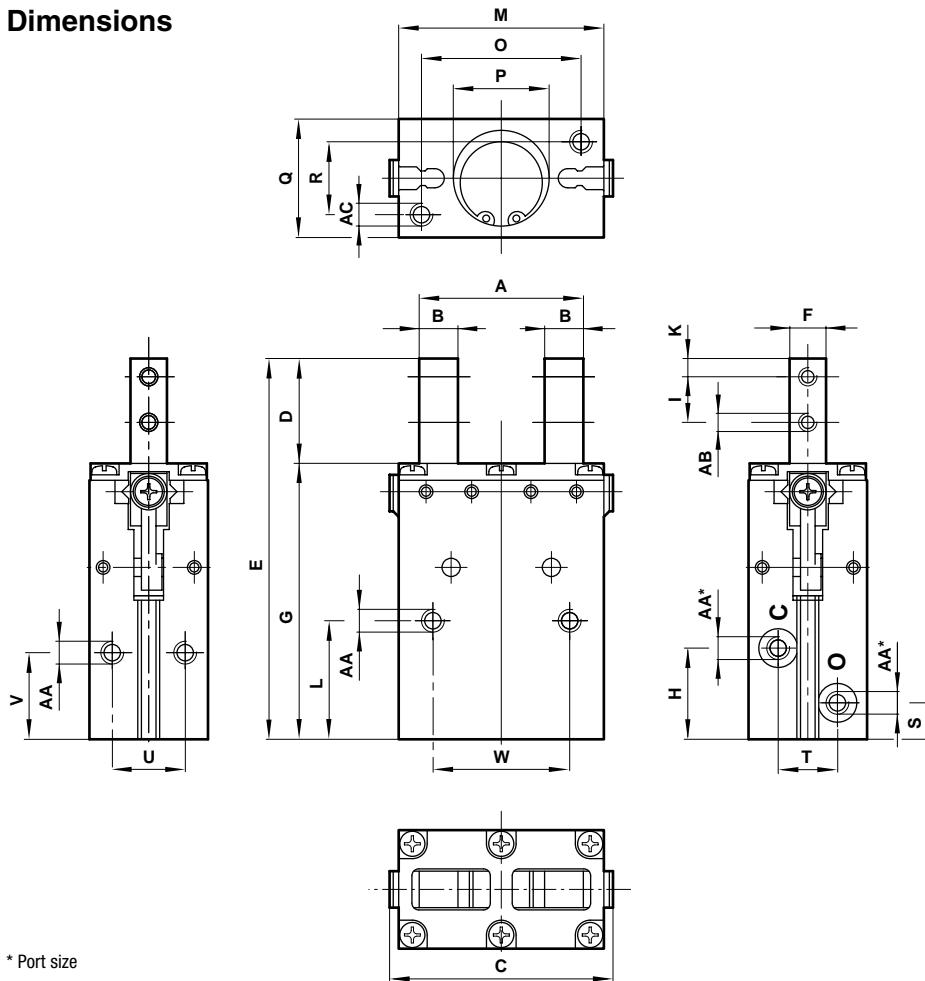

\* Port size

	Ø	A	B	C	D	E	F	G	H	I	K
M/160343/M/11	10	17 + 1,6/-0,2 (open) 13 ± 0,4 (closed)	4,5	25 max.	16,5	59,5	5,5 - 0,03	43	15	6	3
M/160344/M/11	16	26 + 2,3 (open) 18 + 0,6/-0,2 (closed)	6,5	37,5 max	19	71	7 - 0,03	52	17,5	8	3
M/160345/M/11	20	36 + 1,5/-0,9 (open) 24 + 0,1/-0,9 (closed)	8,5	49 max	23	83,5	8 - 0,04	60,5	20	10	4
M/160346/M/11	25	42 + 1,0/-0,7 (open) 28 ± 0,4 (closed)	10	57,5 max	27	95	10 - 0,03	68	23	12	5

	Ø	L	M	O	P	Q	R	S	T	U	V	W	AA	AB	AC	kg
M/160343/M/11	10	20	23	17	Ø 11 + 0,05 deep 1,5	16	10	7,5	10	10	16	18	M3 x 0,5	M3 x 0,5 deep 5	M3 x 0,5	0,05
M/160344/M/11	16	23	34	26	Ø 17 + 0,05 deep 1,5	22	14	7,5	12	14	18	24	M5 x 0,8	M4 x 0,7 deep 7	M3 x 0,5	0,12
M/160345/M/11	20	26	45	35	Ø 21 + 0,05 deep 1,5	26	16	8	13	16	19	30	M5 x 0,8	M5 x 0,8 deep 8	M4 x 0,7	0,22
M/160346/M/11	25	30	52	40	Ø 26 + 0,05 deep 1,5	32	20	9	18	20	22	36	M5 x 0,8	M6 x 1,0 deep 10	M5 x 0,8	0,37

## Warning

These products are intended for use in industrial compressed air systems only. Do not use these products where pressures and temperatures can exceed those listed under 'Technical Data'.

Before using these products with fluids other than those specified, for non-industrial applications, life-support systems, or other applications not within published specifications, consult **NORGREN**.

Through misuse, age, or malfunction, components used in fluid power systems can fail in various modes.

The system designer is warned to consider the failure modes of all component parts used in fluid power systems and to provide adequate safeguards to prevent personal injury or damage to equipment in the event of such failure.

**System designers must provide a warning to end users in the system instructional manual if protection against a failure mode cannot be adequately provided.**

System designers and end users are cautioned to review specific warnings found in instruction sheets packed and shipped with these products.