

- Quick, easy installation
- Converts vacuum signal into compressed air output

**Technical Data**

Medium:

Air filtered and non-lubricated

Operation:

M/58021 Normally open

M/58022 Normally closed

Operating Pressure (Pressure Valve):

1,5 to 8 bar

Operating Pressure (Vacuum Switch):

0 to -1 bar

Adjustment:

-0,2 to -0,8 bar

Operating Temperature:

-10°C to +60°C

Tube Connection:

4 mm O/D tube

Materials:

Anodised aluminium body, PA valve

**Ordering Information**

To order a pneumatic vacuum switch (normally open) quote: M/58021

To order a pneumatic vacuum switch (normally closed) quote: M/58022

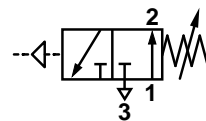

M/58021

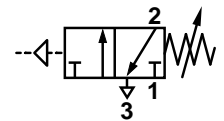

M/58022

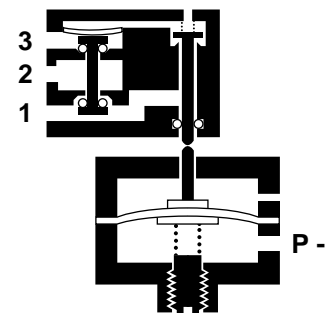



## Basic Dimensions

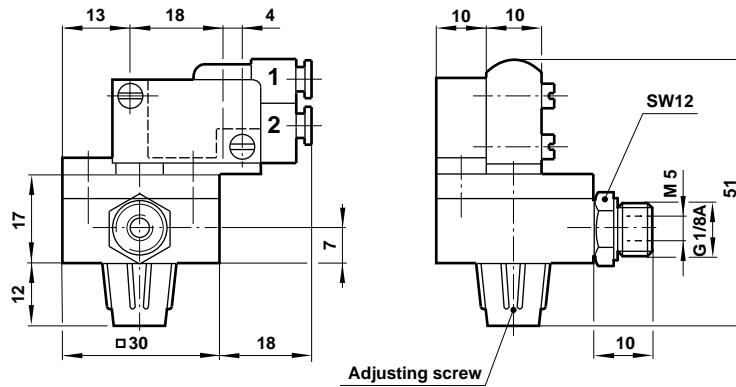

## Warning

These products are intended for use in industrial compressed air systems only. Do not use these products where pressures and temperatures can exceed those listed under 'Technical Data'.

Before using these products with fluids other than those specified, for non-industrial applications, life-support systems, or other applications not within published specifications, consult NORGREN.

Through misuse, age, or malfunction, components used in fluid power systems can fail in various modes.

The system designer is warned to consider the failure modes of all component parts used in fluid power systems and to provide adequate safeguards to prevent personal injury or damage to equipment in the event of such failure.

**System designers must provide a warning to end users in the system instructional manual if protection against a failure mode cannot be adequately provided.**

System designers and end users are cautioned to review specific warnings found in instruction sheets packed and shipped with these products.