

**Inline 3/2, 5/2 and 5/3 Spool Valves  
Solenoid and Pilot Actuated  
G<sup>1/8</sup> and G<sup>1/4</sup>**

- Wide range of low power solenoids
- End, side or face mounting solenoids
- Light weight corrosion resistant materials
- High flow capacity

**Technical Data**

Medium:

Compressed air, filtered, lubricated and non-lubricated

Operation:

Spool Valve, indirectly actuated

Mounting:

Through-holes in valve body

Port Size:

G<sup>1/8</sup>, G<sup>1/4</sup>

Operating Pressure:

Maximum 10 bar. For details see overleaf.

Flow Characteristics:

Size	Function	'C'	'b'	'A'	l/min	Cv	Kv
G <sup>1/8</sup>	3/2, 5/2 & 5/3	1,4	0,441	5,5	335	0,34	0,295
G <sup>1/4</sup>	3/2, 5/2 & 5/3	4,0	0,434	16	965	0,98	0,853

Operating Temperature:

0°C\* to +70°C Pilot valves

+5°C to +50°C Solenoid valves

\* Consult our Technical Service for use below +2°C.

Materials

Diecast aluminium alloy body, aluminium or glass filled nylon end cover, nitrile rubber seals

**Ordering Information**

To order miniature solenoid models without coil(s), quote the appropriate model number. For standard models and miniature solenoid models complete with coil(s), replace the last five digits of the model number with the required voltage code (see table on page 6.)

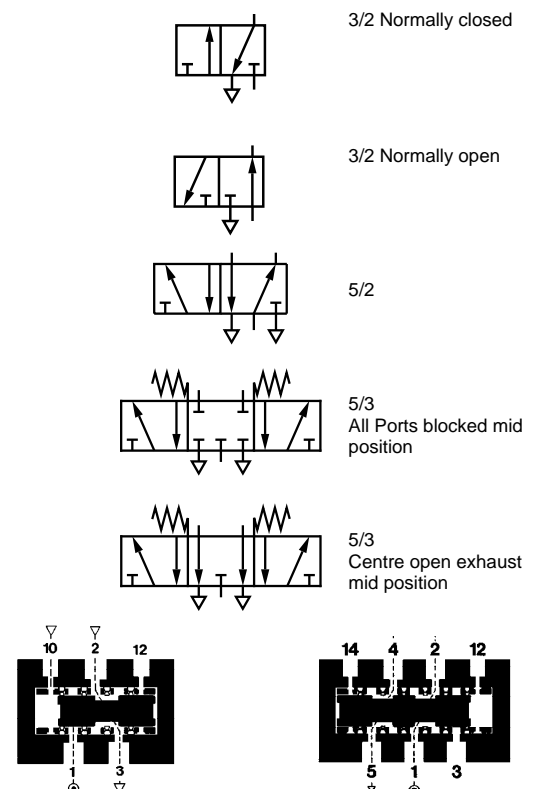

For technical data on manual and mechanical Super X valves see Section 5.6.081



**General Information**  
**G<sup>1</sup>/<sub>8</sub> Valves, 3/2**

Symbol	Model	Solenoid Mounting	Solenoid Pilot	Operator	Return	Operating Pressure	Pilot Pressure	Weight (kg)	Spares Kit Ref.	for details see page -
	14 1235 ** **	Side	Internal	Solenoid	Spring	2 - 10	-	0,42	X4 1000 50	06
	14 1135 ** **	Face	Internal	Solenoid	Spring	2 - 10	-	0,40	X4 1000 50	07
	14 1835 ** **	End	Internal	Solenoid	Spring	2 - 10	-	0,36	X4 1000 50	07
	14 1234 ** **	Side	Internal	Solenoid Priority	Pilot	2 - 10	-	0,44	X4 1000 50	07
	14 1134 ** **	Face	Internal	Solenoid Priority	Pilot	2 - 10	-	0,44	X4 1000 50	08
	14 1834 ** **	End	Internal	Solenoid Priority	Pilot	2 - 10	-	0,39	X4 1000 50	08
	14 1232 ** **	Side	Internal	Solenoid	Solenoid	2 - 10	-	0,50	X4 1000 50	09
	14 1131 ** **	Face	Internal	Solenoid	Solenoid	2 - 10	-	0,50	X4 1000 50	09
	14 1838 ** **	End	Internal	Solenoid	Solenoid	2 - 10	-	0,45	X4 1000 50	09
	14 1532 ** **	Side	Internal	Solenoid	Spring	2 - 10	-	0,43	X4 1000 50	06
	14 1531 ** **	Face	Internal	Solenoid	Spring	2 - 10	-	0,41	X4 1000 50	07
	14 1432 ** **	Side	Internal	Solenoid Priority	Pilot	2 - 10	-	0,42	X4 1000 50	08
	14 1431 ** **	Face	Internal	Solenoid Priority	Pilot	2 - 10	-	0,44	X4 1000 50	08
	14 1735 ** **	Side	External	Solenoid	Spring	-0,93 - 10	2 - 10	0,42	X4 1000 50	06
	14 1635 ** **	Face	External	Solenoid	Spring	-0,93 - 10	2 - 10	0,42	X4 1000 50	07
	14 1734 ** **	Side	External	Solenoid Priority	Pilot	-0,93 - 10	2 - 10	0,46	X4 1000 50	07
	14 1634 ** **	Face	External	Solenoid Priority	Pilot	-0,93 - 10	2 - 10	0,33	X4 1000 50	08
	14 1737 ** **	Side	External	Solenoid	Solenoid	-0,93 - 10	2 - 10	0,44	X4 1000 50	09
	14 1636 ** **	Face	External	Solenoid	Solenoid	-0,93 - 10	2 - 10	0,37	X4 1000 50	09
	14 1537 ** **	Side	External	Solenoid	Spring	-0,93 - 10	2 - 10	0,41	X4 1000 50	06
	14 1536 ** **	Face	External	Solenoid	Spring	-0,93 - 10	2 - 10	0,41	X4 1000 50	07
	14 1437 ** **	Side	External	Solenoid Priority	Pilot	-0,93 - 10	2 - 10	0,32	X4 1000 50	08
	14 1436 ** **	Face	External	Solenoid Priority	Pilot	-0,93 - 10	2 - 10	0,32	X4 1000 50	08
	03 0401 02	-	-	Pilot	Spring	-0,93 - 10	4 - 10	0,19	03 8447 02	09
	03 0413 02	-	-	Pilot	Spring	-0,93 - 10	2 - 10	0,21	03 8447 02	10
	03 0407 02	-	-	Pilot	Pilot	-0,93 - 10	2 - 10	0,22	03 8447 02	10
	03 0412 02	-	-	Pressure Priority	Pilot	-0,93 - 10	2 - 10	0,25	03 8447 02	10
	03 0356 02	-	-	Pressure Bleed	Spring	-0,93 - 10	2 - 10	0,21	03 8447 02	10
	03 0356 50	-	-	Pressure Bleed	Spring	-0,93 - 10	2 - 10	0,21	03 8447 02	10
	03 0370 02	-	-	Pressure or Vacuum	Spring	-0,93 - 10	0,3 - 2 or 0,4 Vac. min.	0,33	03 8370 02	11
	03 0434 03	-	-	Low Pressure Pilot	Spring	-0,93 - 10	0,2 min.	0,21	03 8433 02	11
	03 0435 03	-	-	Low Pressure Pilot	Pilot	-0,93 - 10	0,2 min. Reset pressure 2 bar min	0,31	03 8433 02	11
	03 0433 03	-	-	Low Pressure Pilot	Low Pressure Pilot	-0,93 - 10	0,2 min.	0,41	03 8433 02	11

**Warning**

These products are intended for use in industrial compressed air systems only. Do not use these products where pressures and temperatures can exceed those listed under 'Technical Data'.

Before using these products with fluids other than those specified, for non-industrial applications, life-support systems, or other applications not within published specifications, consult Norgren.

Through misuse, age, or malfunction, components used in fluid power systems can fail in various modes. The system designer is warned to consider the failure modes of all component parts used in fluid power systems and to provide adequate safeguards to prevent personal injury or damage to equipment in the event of such failure.

**System designers must provide a warning to end users in the system instructional manual if protection against a failure mode cannot be adequately provided.**

System designers and end users are cautioned to review specific warnings found in instruction sheets packed and shipped with these products where applicable.



G<sup>1</sup>/<sub>8</sub> Valves, 5/2

Symbol	Model	Solenoid Mounting	Solenoid Pilot	Operator	Return	Operating Pressure (bar)	Pilot Pressure (bar)	Weight (kg)	Spares Kit	for details see page -
	X4 1255 ****	Side	Internal	Solenoid	Spring	2 - 10	-	0,50	X4 1000 50	12
	X4 1155 ****	Face	Internal	Solenoid	Spring	2 - 10	-	0,52	X4 1000 50	12
	X4 1855 ****	End	Internal	Solenoid	Spring	2 - 10	-	0,69	X4 1000 50	12
	X4 1254 ****	Side	Internal	Solenoid Priority	Pilot	2 - 10	-	0,52	X4 1000 50	12
	X4 1154 ****	Face	Internal	Solenoid Priority	Pilot	2 - 10	-	0,53	X4 1000 50	13
	X4 1854 ****	End	Internal	Solenoid Priority	Pilot	2 - 10	-	0,49	X4 1000 50	13
	X4 1252 ****	Side	Internal	Solenoid	Solenoid	2 - 10	-	0,61	X4 1000 50	13
	X4 1151 ****	Face	Internal	Solenoid	Solenoid	2 - 10	-	0,60	X4 1000 50	14
	X4 1858 ****	End	Internal	Solenoid	Solenoid	2 - 10	-	0,56	X4 1000 50	13
	X4 1755 ****	Side	External	Solenoid	Spring	-0,93 - 10	2 - 10	0,50	X4 1000 50	12
	X4 1655 ****	Face	External	Solenoid	Spring	-0,93 - 10	2 - 10	0,50	X4 1000 50	12
	X4 1754 ****	Side	External	Solenoid Priority	Pilot	-0,93 - 10	2 - 10	0,54	X4 1000 50	12
	X4 1654 ****	Face	External	Solenoid Priority	Pilot	-0,93 - 10	2 - 10	0,52	X4 1000 50	13
	X4 1757 ****	Side	External	Solenoid	Solenoid	-0,93 - 10	2 - 10	0,62	X4 1000 50	13
	X4 1656 ****	Face	External	Solenoid	Solenoid	-0,93 - 10	2 - 10	0,63	X4 1000 50	14
	X3 0441 02	-	-	Pilot	Spring	-0,93 - 10	3 - 10	0,30	03 8447 02	14
	X3 0447 02	-	-	Pilot	Pilot	-0,93 - 10	2 - 70	0,35	03 8447 02	14
	X3 0452 02	-	-	Pressure Priority	Pilot	-0,93 - 10	3 - 10	0,33	03 8447 02	14
	X3 0396 02 & 03 0356 50	-	-	Pressure Bleed	Spring	-0,93 - 10	2 - 10	0,30	03 8447 02	15
	X3 0390 02	-	-	Pressure or Vacuum	Spring	-0,93 - 10	0,3 - 2 Or 0,4 Vac. min	0,55	03 8370 02	15
	X3 0474 03	-	-	Low Pressure Pilot	Spring	-0,93 - 10	0,2 min	0,36	03 8433 02	15
	X3 0475 03	-	-	Low Pressure Pilot	Pilot	-0,93 - 10	0,2 min Reset pressure 2 bar min	0,43	03 8433 02	15
	X3 0473 03	-	-	Low Pressure Pilot	Low Pressure Pilot	-0,93 - 10	0,2 min	0,48	03 8433 02	16

G<sup>1</sup>/<sub>8</sub> Valves, 5/3

Symbol	Model	Solenoid Mounting	Solenoid Pilot	Operator	Mid-position	Return	Operating Pressure (bar)	Pilot Pressure (bar)	Weight (kg)	Spares Kit	for details see page -
	X4 1282 ****	Side	Internal	Solenoid	A.P.B.	Solenoid	3 - 10	-	0,67	X4 1000 50	16
	X4 1181 ****	Face	Internal	Solenoid	A.P.B.	Solenoid	3 - 10	-	0,67	X4 1000 50	16
	X4 1292 ****	Side	Internal	Solenoid	C.O.E.	Solenoid	3 - 10	-	0,65	X4 1000 50	16
	X4 1191 ****	Face	Internal	Solenoid	C.O.E.	Solenoid	3 - 10	-	0,65	X4 1000 50	16
	X4 1787 ****	Side	External	Solenoid	A.P.B.	Solenoid	-0,93 - 10	3 - 10	0,68	X4 1000 50	16
	X4 1686 ****	Face	External	Solenoid	A.P.B.	Solenoid	-0,93 - 10	3 - 10	0,68	X4 1000 50	16
	X4 1797 ****	Side	External	Solenoid	C.O.E.	Solenoid	-0,93 - 10	3 - 10	0,68	X4 1000 50	16
	X4 1696 ****	Face	External	Solenoid	C.O.E.	Solenoid	-0,93 - 10	3 - 10	0,68	X4 1000 50	16

A.P.B. = All Ports Blocked    C.O.E. = Centre Open Exhaust



G<sup>1</sup>/<sub>4</sub> Valves, 3/2

Symbol	Model	Solenoid Mounting	Solenoid Pilot	Operator	Return	Operating Pressure (bar)	Pilot Pressure (bar)	Weight (kg)	Spares Kit	for details see page -
	14 2235 ** ** **	Side	Internal	Solenoid	Spring	2 - 10	-	0,56	X4 2000 50	16
	14 2135 ** ** **	Face	Internal	Solenoid	Spring	2 - 10	-	0,55	X4 2000 50	17
	14 2835 ** ** **	End	Internal	Solenoid	Spring	2 - 10	-	0,51	X4 2000 50	17
	14 2538 ** ** **	End	Internal	Solenoid	Spring	2 - 10	-	0,51	X4 2000 50	18
	14 2234 ** ** **	Side	Internal	Solenoid Priority	Pilot	2 - 10	-	0,56	X4 2000 50	18
	14 2134 ** ** **	Face	Internal	Solenoid Priority	Pilot	2 - 10	-	0,45	X4 2000 50	18
	14 2834 ** ** **	End	Internal	Solenoid Priority	Pilot	2 - 10	-	0,56	X4 2000 50	19
	14 2232 ** ** **	Side	Internal	Solenoid	Solenoid	2 - 10	-	0,63	X4 2000 50	19
	14 2131 ** ** **	Face	Internal	Solenoid	Solenoid	2 - 10	-	0,63	X4 2000 50	20
	14 2838 ** ** **	End	Internal	Solenoid	Solenoid	2 - 10	-	0,57	X4 2000 50	19
	14 2532 ** ** **	Side	Internal	Solenoid	Spring	2 - 10	-	0,54	X4 2000 50	17
	14 2531 ** ** **	Face	Internal	Solenoid	Spring	2 - 10	-	0,54	X4 2000 50	17
	14 2432 ** ** **	Side	Internal	Solenoid Priority	Pilot	2 - 10	-	0,56	X4 2000 50	18
	14 2431 ** ** **	Face	Internal	Solenoid Priority	Pilot	2 - 10	-	0,42	X4 2000 50	19
	14 2735 ** ** **	Side	External	Solenoid	Spring	-0,93 - 10	2 - 10	0,54	X4 2000 50	16
	14 2635 ** ** **	Face	External	Solenoid	Spring	-0,93 - 10	2 - 10	0,55	X4 2000 50	17
	14 2734 ** ** **	Side	External	Solenoid Priority	Pilot	-0,93 - 10	2 - 10	0,56	X4 2000 50	18
	14 2634 ** ** **	Face	External	Solenoid Priority	Pilot	-0,93 - 10	2 - 10	0,58	X4 2000 50	18
	14 2737 ** ** **	Side	External	Solenoid	Solenoid	-0,93 - 10	2 - 10	0,62	X4 2000 50	19
	14 2636 ** ** **	Face	External	Solenoid	Solenoid	-0,93 - 10	2 - 10	0,51	X4 2000 50	20
	14 2537 ** ** **	Side	External	Solenoid	Spring	-0,93 - 10	2 - 10	0,54	X4 2000 50	17
	14 2536 ** ** **	Face	External	Solenoid	Spring	-0,93 - 10	2 - 10	0,57	X4 2000 50	17
	14 2437 ** ** **	Side	External	Solenoid Priority	Pilot	-0,93 - 10	2 - 10	0,52	X4 2000 50	18
	14 2436 ** ** **	Face	External	Solenoid Priority	Pilot	-0,93 - 10	2 - 10	0,63	X4 2000 50	19
	03 0601 02	-	-	Pilot	Spring	-0,93 - 10	2 - 10	0,42	03 8612 02	20
	03 0613 02	-	-	Pilot	Spring	-0,93 - 10	4 - 10	0,42	03 8612 02	20
	03 0607 02	-	-	Pilot	Pilot	-0,93 - 10	2 - 10	0,42	03 8612 02	20
	03 0612 02	-	-	Pilot Priority	Pilot	-0,93 - 10	2 - 10	0,42	03 8612 02	20



G<sup>1</sup>/<sub>4</sub> Valves, 5/2

Symbol	Model	Solenoid Mounting	Solenoid Pilot	Operator	Return	Operating Pressure (bar)	Pilot Pressure (bar)	Weight (kg)	Spares Kit	for details see page -
	X4 2255 ** ****	Side	Internal	Solenoid	Spring	2 - 10	-	0,67	X4 2000 50	21
	X4 2155 ** ****	Face	Internal	Solenoid	Spring	2 - 10	-	0,67	X4 2000 50	21
	X4 2855 ** ****	End	Internal	Solenoid	Spring	2 - 10	-	0,67	X4 2000 50	21
	X4 2254 ** ****	Side	Internal	Solenoid Priority	Pilot	2 - 10	-	0,67	X4 2000 50	21
	X4 2154 ** ****	Face	Internal	Solenoid Priority	Pilot	2 - 10	-	0,70	X4 2000 50	22
	X4 2854 ** ****	End	Internal	Solenoid Priority	Pilot	2 - 10	-	0,69	X4 2000 50	22
	X4 2252 ** ****	Side	Internal	Solenoid	Solenoid	2 - 10	-	0,75	X4 2000 50	22
	X4 2151 ** ****	Face	Internal	Solenoid	Solenoid	2 - 10	-	0,78	X4 2000 50	23
	X4 2858 ** ****	End	Internal	Solenoid	Solenoid	2 - 10	-	0,69	X4 2000 50	22
	X4 2755 ** ****	Face	External	Solenoid	Spring	-0,93 - 10	2 - 10	0,66	X4 2000 50	21
	X4 2655 ** ****	Face	External	Solenoid	Spring	-0,93 - 10	2 - 10	0,67	X4 2000 50	21
	X4 9251 ** ****	End	External	Solenoid	Spring	-0,93 - 10	2 - 10	0,65	X4 2000 50	21
	X4 2754 ** ****	Side	External	Solenoid Priority	Pilot	-0,93 - 10	2 - 10	0,69	X4 2000 50	21
	X4 2654 ** ****	Face	External	Solenoid Priority	Pilot	-0,93 - 10	2 - 10	0,69	X4 2000 50	22
	X4 2757 ** ****	Side	External	Solenoid	Solenoid	-0,93 - 10	2 - 10	0,75	X4 2000 50	22
	X4 2656 ** ****	Face	External	Solenoid	Solenoid	-0,93 - 10	2 - 10	0,78	X4 2000 50	23
X4 9252 ** ****	End	External	Solenoid	Solenoid	Solenoid	-0,93 - 10	2 - 10	0,75	X4 2000 50	22
	X3 0641 02	-	-	Pilot	Spring	-0,93 - 10	3 - 10	0,50	03 8612 02	23
	X3 0647 02	-	-	Pilot	Pilot	-0,93 - 10	3 - 10	0,57	03 8612 02	23
	X3 0652 02	-	-	Pilot Priority	Pilot	-0,93 - 10	3 - 10	0,57	03 8612 02	23

G<sup>1</sup>/<sub>4</sub> Valves, 5/3

Symbol	Model	Solenoid Mounting	Solenoid Pilot	Operator	Mid-position	Return	Operating Pressure (bar)	Pilot Pressure (bar)	Weight (kg)	Spares Kit	for details see page -
	X4 2282 ** ****	Side	Internal	Solenoid	A.P.B.	Solenoid	3 - 10	-	0,85	X4 2000 50	24
	X4 2181 ** ****	Face	Internal	Solenoid	A.P.B.	Solenoid	3 - 10	-	0,86	X4 2000 50	24
	X4 2888 ** ****	End	Internal	Solenoid	A.P.B.	Solenoid	3 - 10	-	0,84	X4 2000 50	24
	X4 2292 ** ****	Side	Internal	Solenoid	C.O.E.	Solenoid	3 - 10	-	0,86	X4 2000 50	24
	X4 2191 ** ****	Face	Internal	Solenoid	C.O.E.	Solenoid	3 - 10	-	0,86	X4 2000 50	24
	X4 2898 ** ****	End	Internal	Solenoid	C.O.E.	Solenoid	3 - 10	-	0,80	X4 2000 50	24
	X4 2787 ** ****	Side	External	Solenoid	A.P.B.	Solenoid	-0,93 - 10	3 - 10	0,86	X4 2000 50	24
	X4 2686 ** ****	Face	External	Solenoid	A.P.B.	Solenoid	-0,93 - 10	3 - 10	0,87	X4 2000 50	24
	X4 2797 ** ****	Side	External	Solenoid	C.O.E.	Solenoid	-0,93 - 10	3 - 10	0,85	X4 2000 50	24
	X4 2696 ** ****	Face	External	Solenoid	C.O.E.	Solenoid	-0,93 - 10	3 - 10	0,87	X4 2000 50	24
	X3 3607 02	-	-	Pilot	A.P.B.	Pilot	-0,93 - 10	3 - 10	0,66	03 8612 02	24
	X3 3647 02	-	-	Pilot	C.O.E.	Pilot	-0,93 - 10	3 - 10	0,68	03 8612 02	24

A.P.B. = All Ports Blocked    C.O.E. = Centre Open Exhaust



**\*\* \*\*\*Voltage and Manual Override Codes**

Voltage	With Manual Override	Without Manual Override
12V d.c	0G 012	0L 012
24V d.c.	0G 024	0L 024
24V 50/60Hz	5G 024	5L 024
48V 50/60Hz	5G 048	5L 048
110V 50/60Hz	5G 110	5L 110
220/240V 50/60Hz	5G 240	5L 240

Note: Valves with end mounted solenoids have manual override fitted as standard

**Electrical Details for Solenoid Operators**

Voltage Tolerance:	d.c.: +10/-15%, a.c.: +10/-15%
Power (a.c. inrush/hold):	d.c.: 2W, a.c.: 4/2,5 VA
Inlet Orifice:	1,0 mm
Exhaust Orifice:	1,2 mm
Terminal Box:	3 pin plug with cable grip (DIN 43 650 Form B)
Cable Entry:	Pg 9
Protection Class:	IP 65 (DIN 40 050)

**G<sup>1</sup>/<sub>8</sub> 14 1235 & 14 1735 Models  
3/2 Single Solenoid Valves**

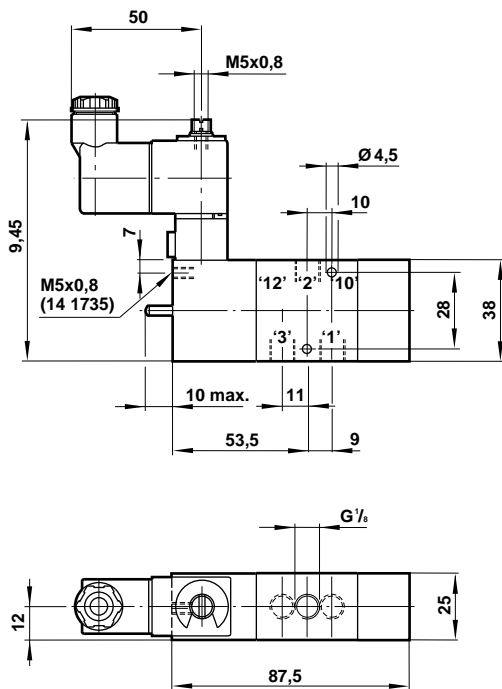

**G<sup>1</sup>/<sub>8</sub> 14 1532 & 14 1537 Models  
3/2 Single Solenoid Valves**

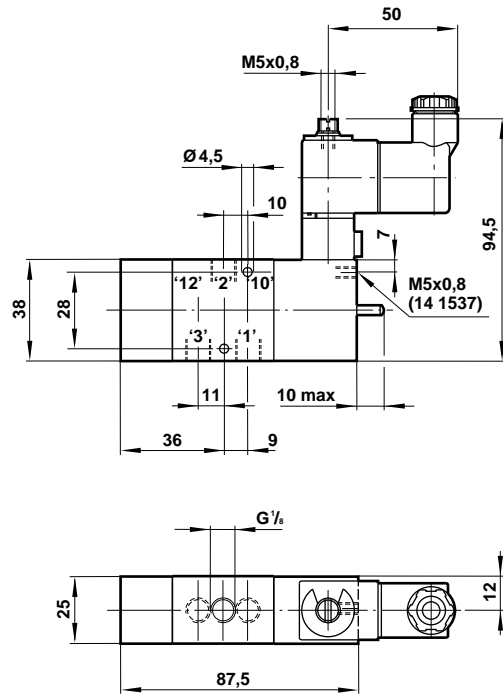



**G<sup>1</sup>/<sub>8</sub> 14 1135 & 14 1635 Models**  
**3/2 Single Solenoid Valves**

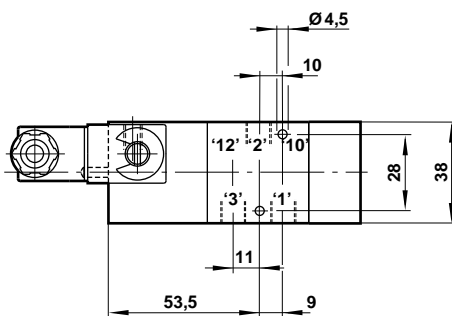
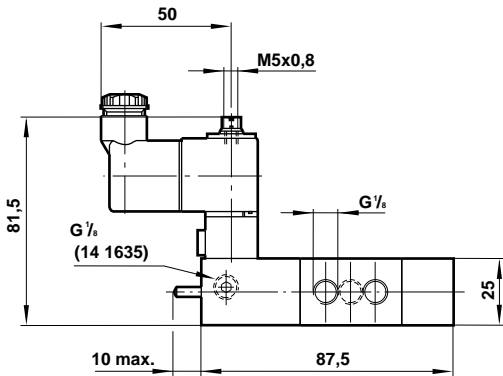

**G<sup>1</sup>/<sub>8</sub> 14 1531 & 14 1536 Models**  
**3/2 Single Solenoid Valves**

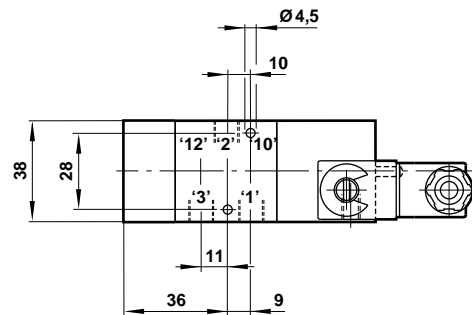
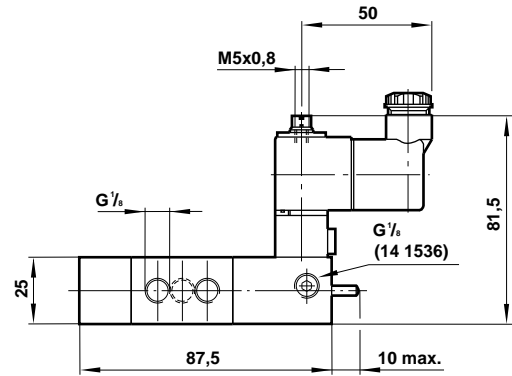

**G<sup>1</sup>/<sub>8</sub> 14 1835 Model**  
**3/2 Single Solenoid Valve**

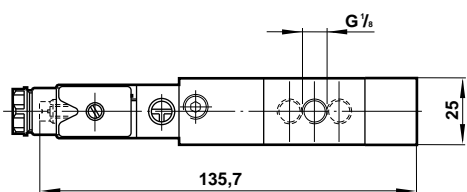
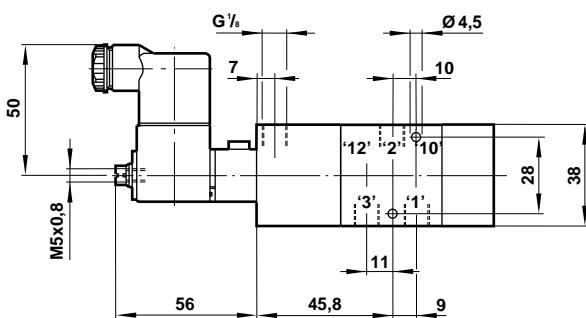

**G<sup>1</sup>/<sub>8</sub> 14 1234 & 14 1734 Models**  
**3/2 Single Solenoid Valves**

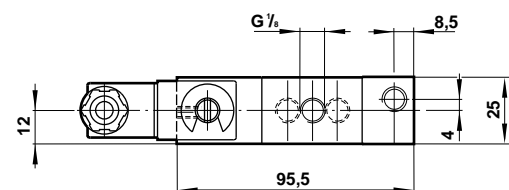
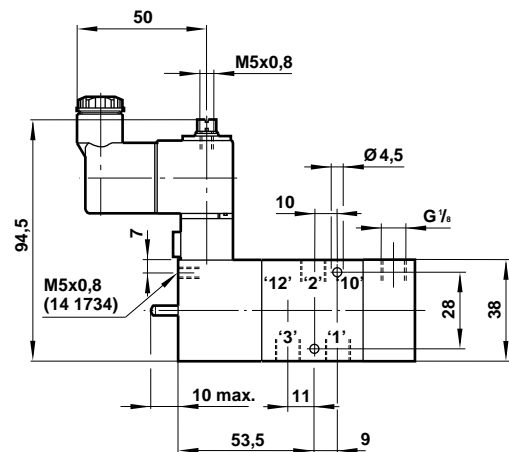

Valve should be mounted with the axis of the spool horizontal.



**G<sup>1</sup>/<sub>8</sub> 14 1432 & 14 1437 Models**  
**3/2 Single Solenoid Valves**

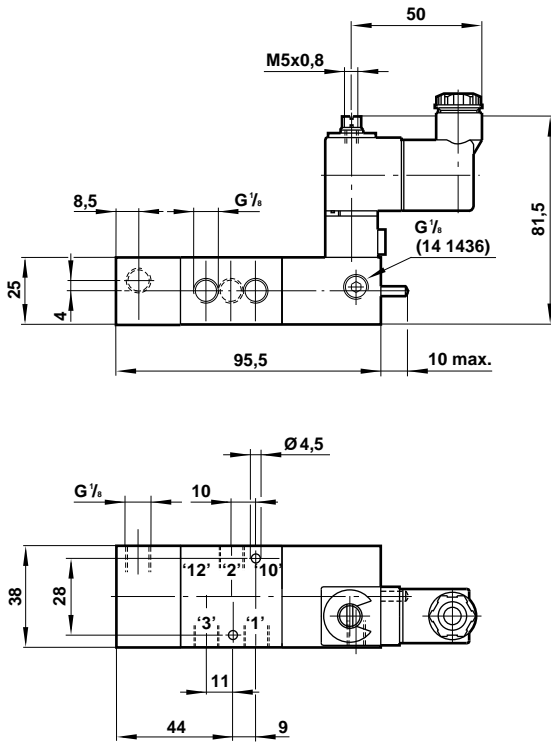

Valve should be mounted with the axis of the spool horizontal.

**G<sup>1</sup>/<sub>8</sub> 14 1134 & 14 1634 Models**  
**3/2 Solenoid Priority Set, Pilot Reset Valves**

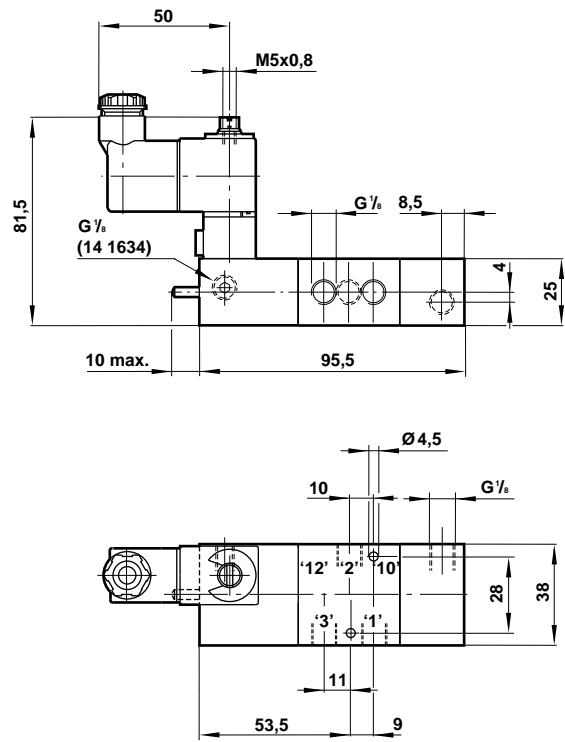

Valve should be mounted with the axis of the spool horizontal.

**G<sup>1</sup>/<sub>8</sub> 14 1431 & 14 1436 Models**  
**3/2 Solenoid Priority Set, Pilot Reset Valves**

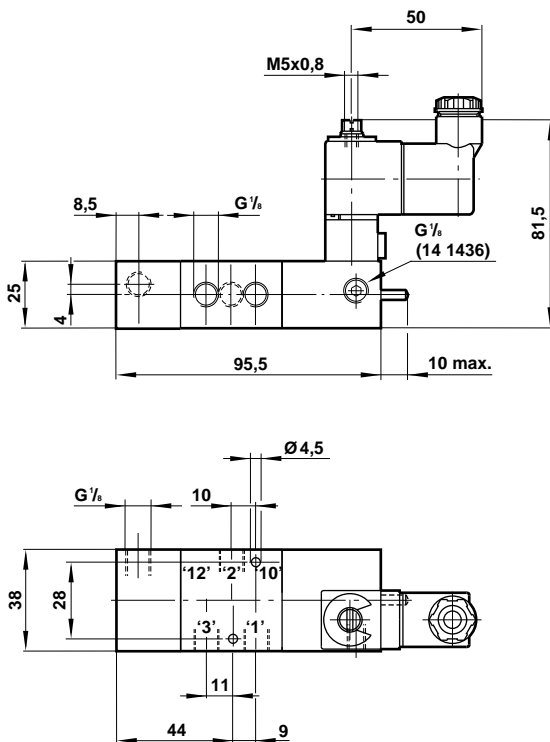

Valve should be mounted with the axis of the spool horizontal.

**G<sup>1</sup>/<sub>8</sub> 14 1834 Models**  
**3/2 Solenoid Priority Set, Pilot Reset Valves**

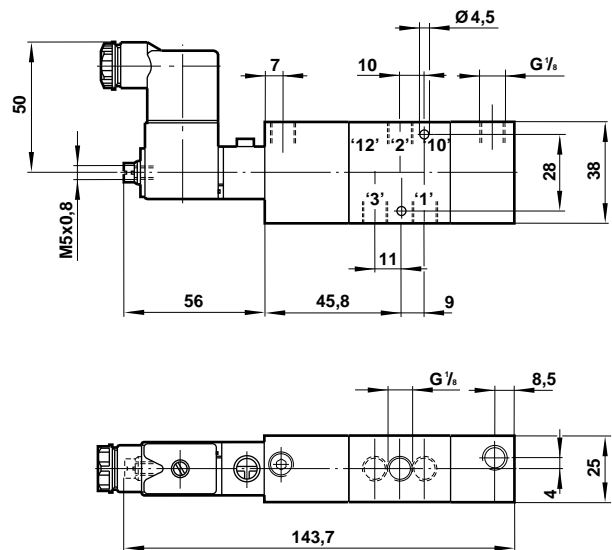

Valve should be mounted with the axis of the spool horizontal.





**G<sup>1</sup>/<sub>8</sub> 14 1838 Model**  
**3/2 Double Solenoid Valve**

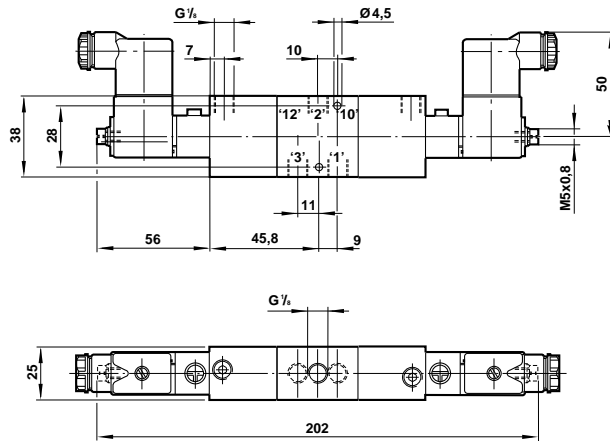

Valve should be mounted with the axis of the spool horizontal.

**G<sup>1</sup>/<sub>8</sub> 14 1232 & 14 1737 Models**  
**3/2 Double Solenoid Valves**

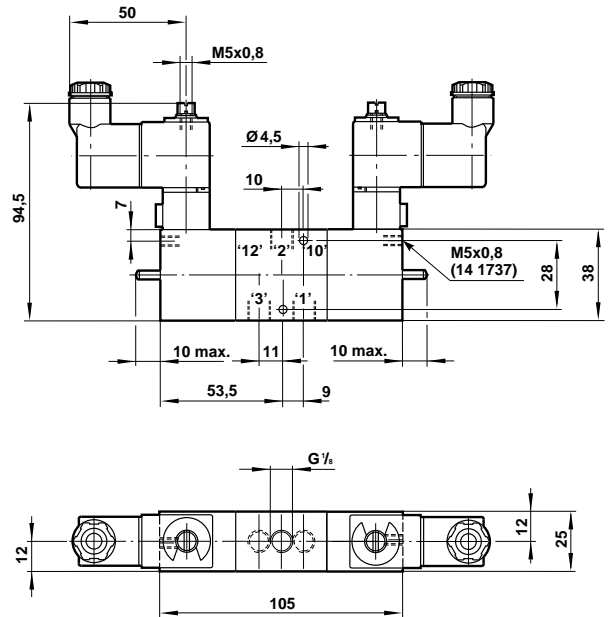

Valve should be mounted with the axis of the spool horizontal.

**G<sup>1</sup>/<sub>8</sub> 14 1131 & 14 1636 Models**  
**3/2 Double Solenoid Valves**

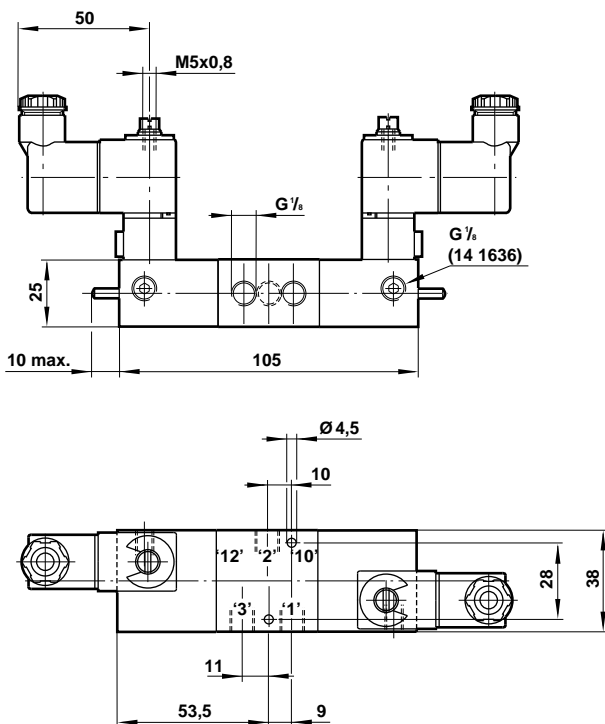

Valve should be mounted with the axis of the spool horizontal.

**G<sup>1</sup>/<sub>8</sub> 03 0401 02 Model**  
**3/2 Single Pilot Valve**

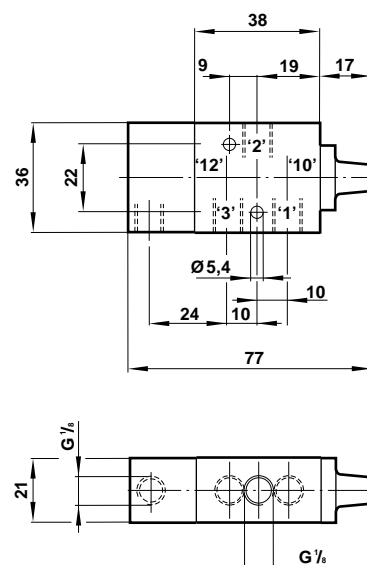



Super 'X'

**G<sup>1</sup>/<sub>8</sub> 03 0413 02 Model**  
**3/2 Single Pilot Valve**

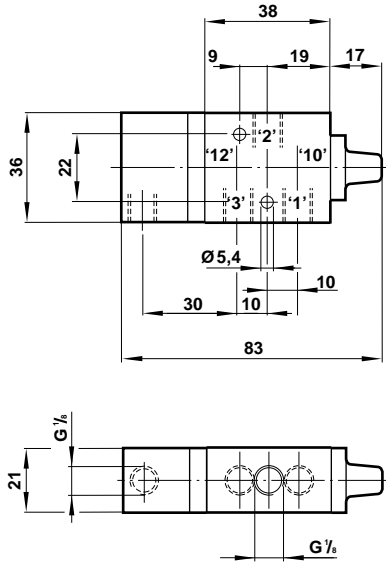

**G<sup>1</sup>/<sub>8</sub> 03 0407 02 Model**  
**3/2 Double Pilot Valve**

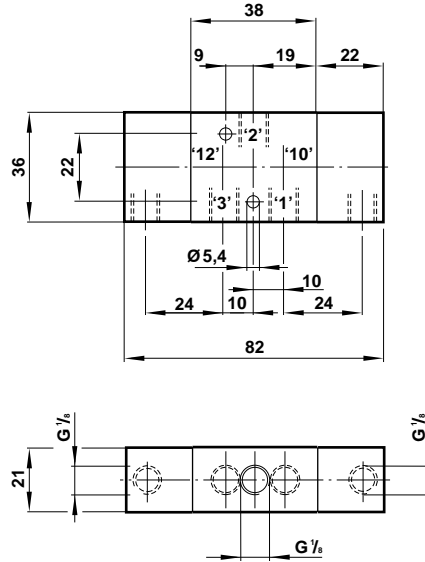

Valve should be mounted with the axis of the spool horizontal.

**G<sup>1</sup>/<sub>8</sub> 03 0412 02 Model**  
**3/2 Pilot Priority Valve**

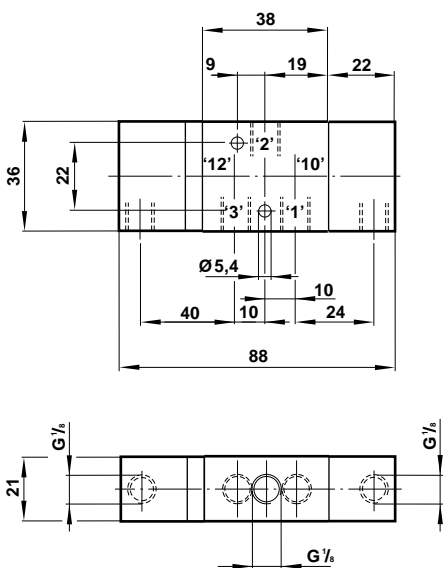

**G<sup>1</sup>/<sub>8</sub> 03 0356 02 Model**  
**3/2 Sensitive Push Button, Bleed Operated Valve**

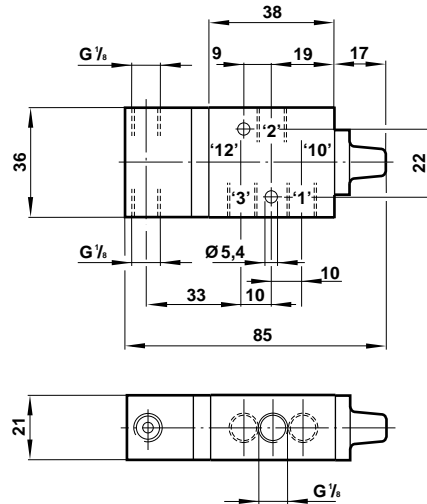

Pt. No. 03035650  
Button Sensor Unit

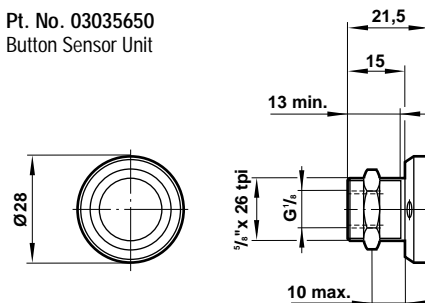

Air consumption:  
0,04 dm<sup>3</sup>/s at 5,5 bar  
Button Sensor Unit:  
**03 0356 50**  
Operating Force: 2 N  
Recommended pipe to Valve:  
Dia. 5mm max. x 3 metres  
max.  
Button Sensor Unit is also  
available separately.

Valve should be mounted with the axis of the spool horizontal.



**G<sup>1</sup>/<sub>8</sub> 03 0370 02 Model**  
**3/2 Single Diaphragm Pilot Valve**

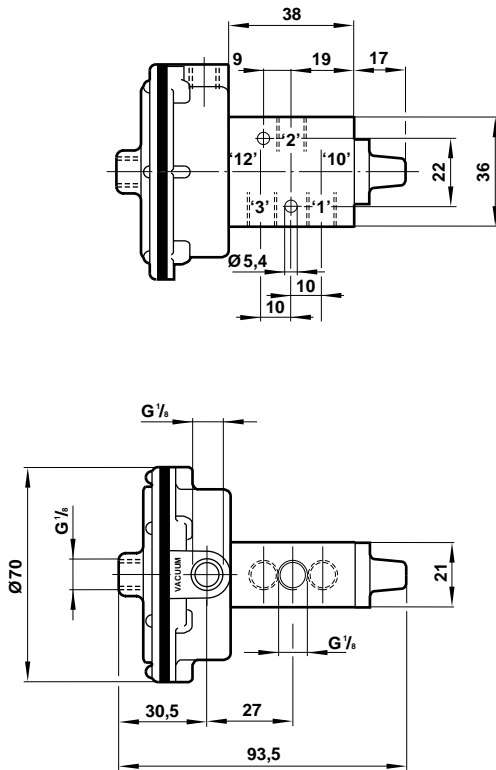

**G<sup>1</sup>/<sub>8</sub> 03 0434 03 Model**  
**3/2 Single Diaphragm (Servo) Pilot Valve**

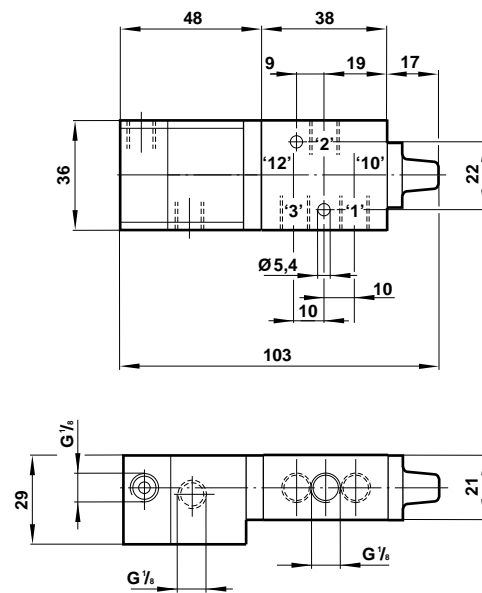

**G<sup>1</sup>/<sub>8</sub> 03 0435 03 Model**  
**3/2 Single Diaphragm (Servo) Pilot, Pilot Return Valve**

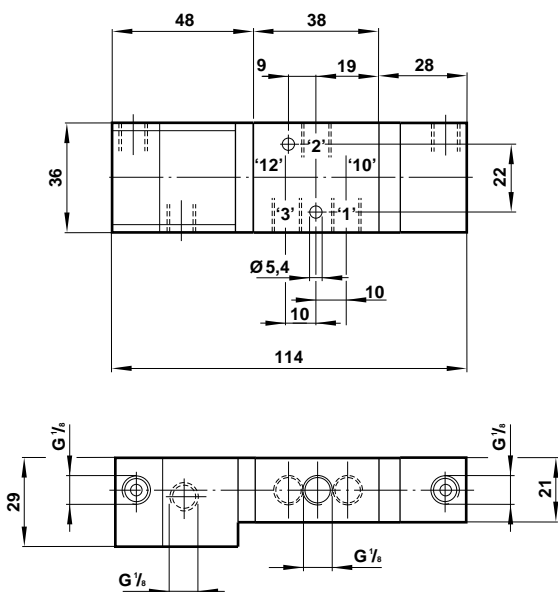

**G<sup>1</sup>/<sub>8</sub> 03 0433 03 Model**  
**3/2 Double Diaphragm (Servo) Pilot Valve**

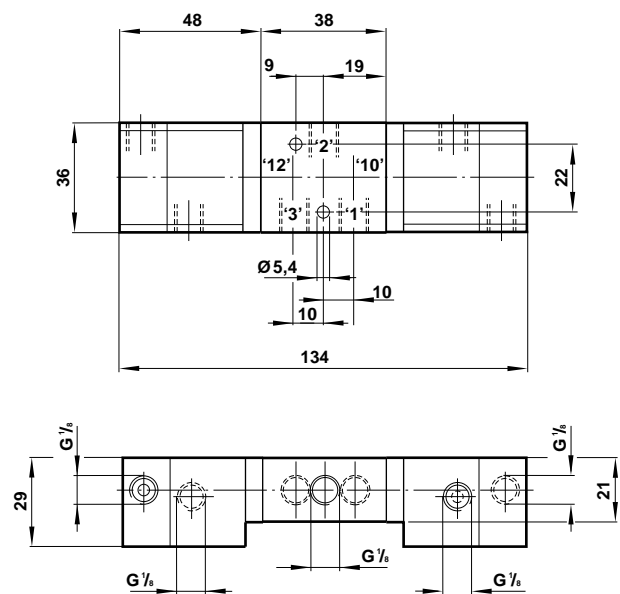

Valve should be mounted with the axis of the spool horizontal.

Valve should be mounted with the axis of the spool horizontal.





**G<sup>1</sup>/<sub>8</sub> X4 1154 & X4 1654 Models**  
**5/2 Solenoid Priority Set, Pressure Reset Valves**

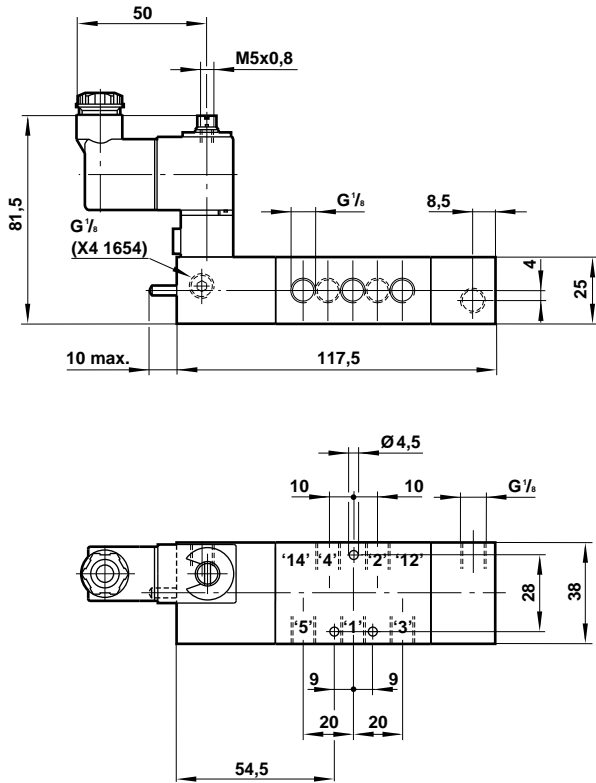

Valve should be mounted with the axis of the spool horizontal.

**G<sup>1</sup>/<sub>8</sub> X4 1854 Model**  
**5/2 Solenoid Priority Set, Pressure Reset Valves**

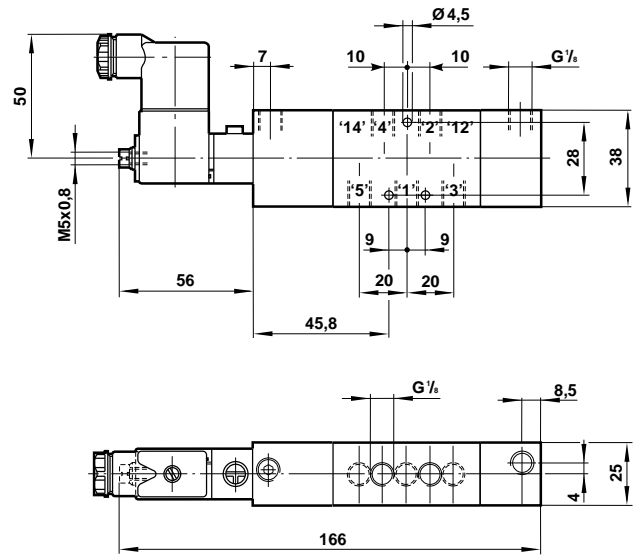

Valve should be mounted with the axis of the spool horizontal.

**G<sup>1</sup>/<sub>8</sub> X4 1858 Model**  
**5/2 Double Solenoid Valve**

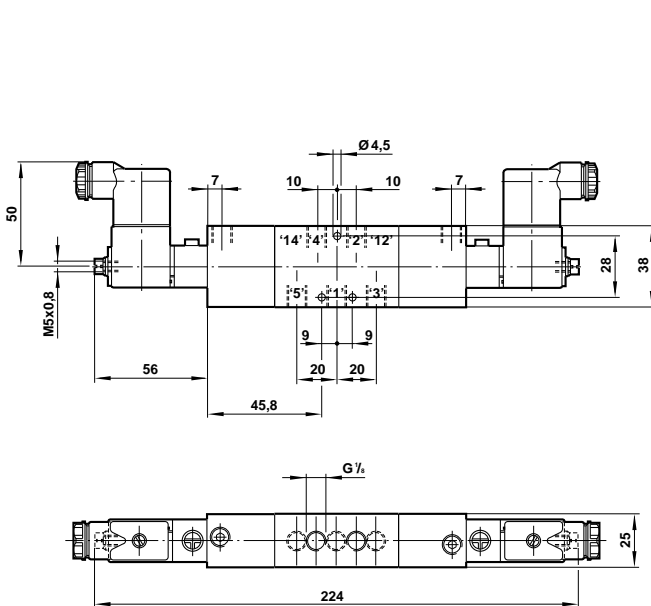

Valve should be mounted with the axis of the spool horizontal.

**G<sup>1</sup>/<sub>8</sub> X4 1252 & X4 1757 Models**  
**5/2 Double Solenoid Valves**

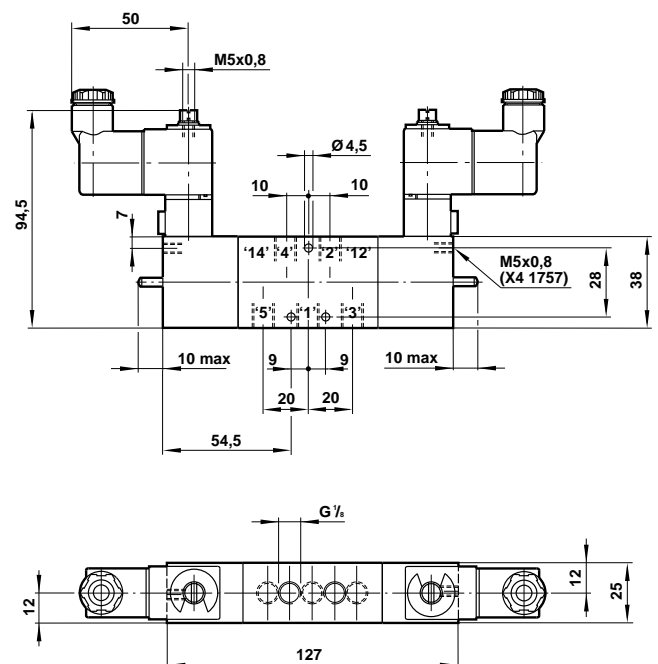



**G<sup>1</sup>/<sub>8</sub> X4 1151 & X4 1656 Models**  
**5/2 Double Solenoid Valves**

**G<sup>1</sup>/<sub>8</sub> X3 0441 02 Model**  
**5/2 Single Pilot Valve**

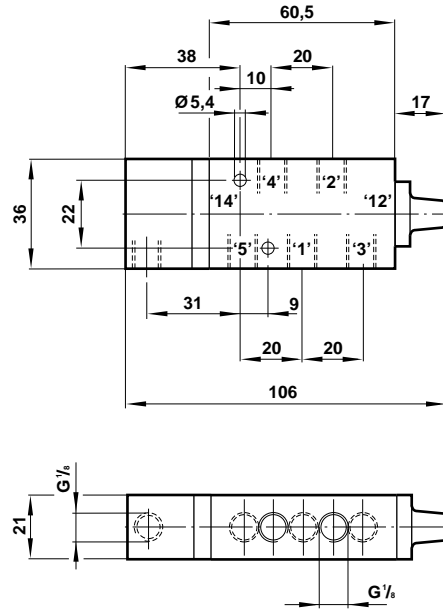
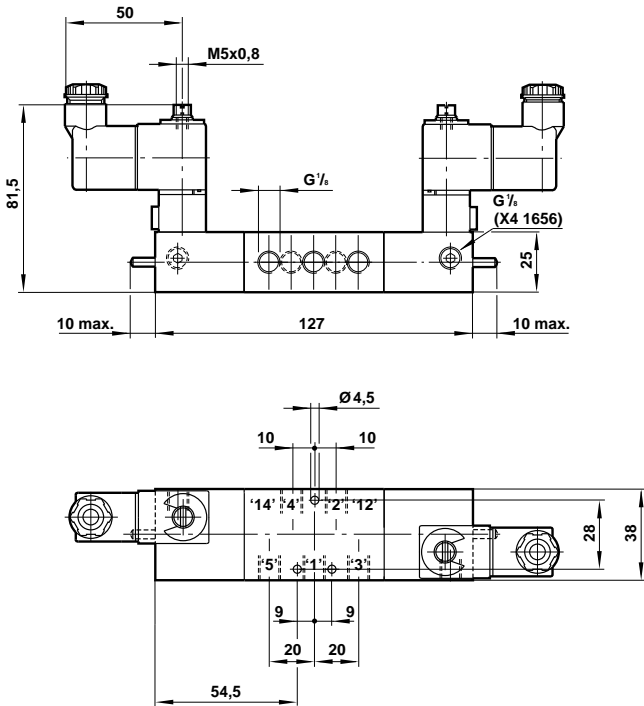

Valve should be mounted with the axis of the spool horizontal.

**G<sup>1</sup>/<sub>8</sub> X3 0447 02 Model**  
**5/2 Double Pilot Valve**

**G<sup>1</sup>/<sub>8</sub> X3 0452 02 Model**  
**5/2 Pilot Priority Valve**

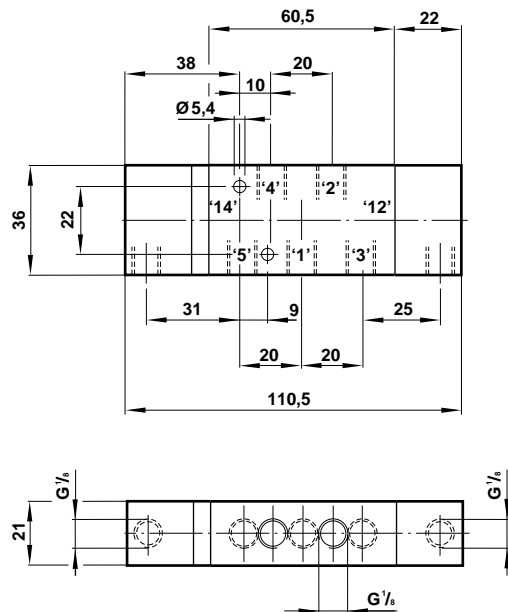
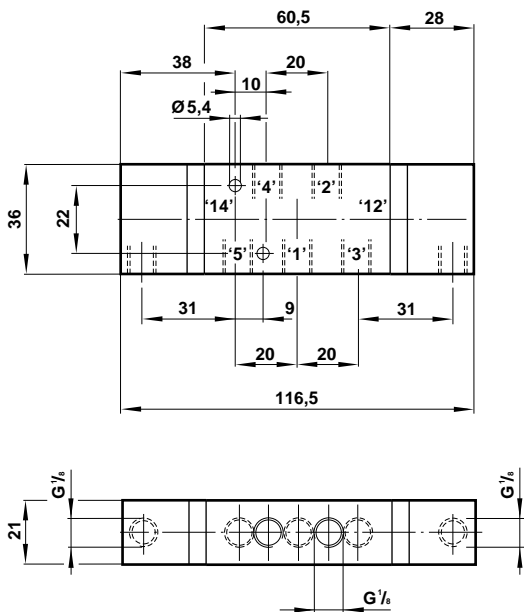

Valve should be mounted with the axis of the spool horizontal.

Valve should be mounted with the axis of the spool horizontal.



**G<sup>1</sup>/<sub>8</sub> X3 0396 02 Model**

**5/2 Sensitive Push Button, Bleed Operated Valve**

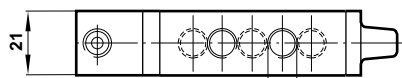
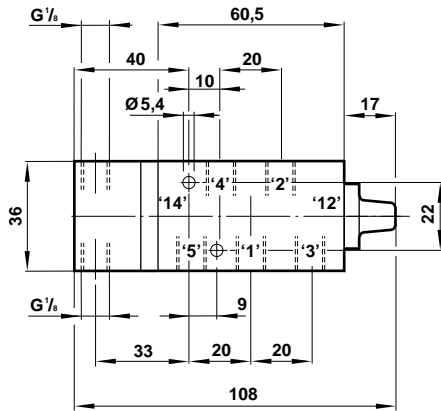

Pt. No. 03035650  
Button Sensor Unit

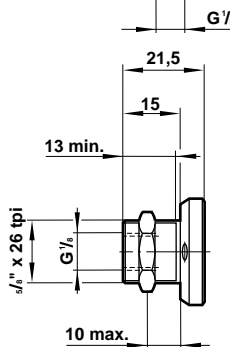
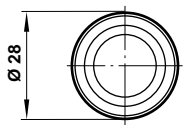

Air consumption:  
0,04 dm<sup>3</sup>/s at 5,5 bar  
Button Sensor Unit:  
03 0356 50  
Operating Force: 2 N  
Recommended pipe to Valve:  
Dia. 5mm max. x 3 metres  
max.  
Button Sensor Unit is also  
available separately.

**G<sup>1</sup>/<sub>8</sub> X3 0390 02 Model**

**5/2 Single Diaphragm Pilot Valve**

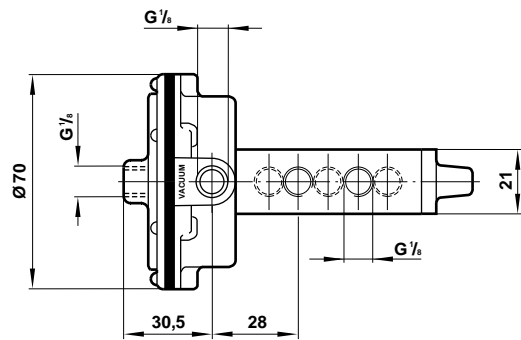
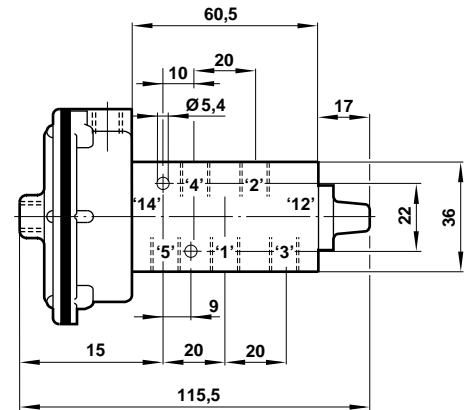

**G<sup>1</sup>/<sub>8</sub> X3 0474 03 Model**

**5/2 Single Diaphragm (Servo) Valve**

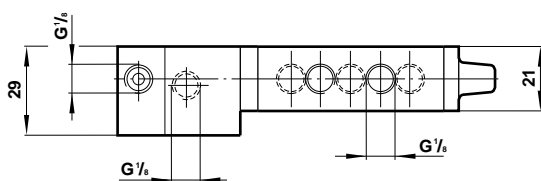
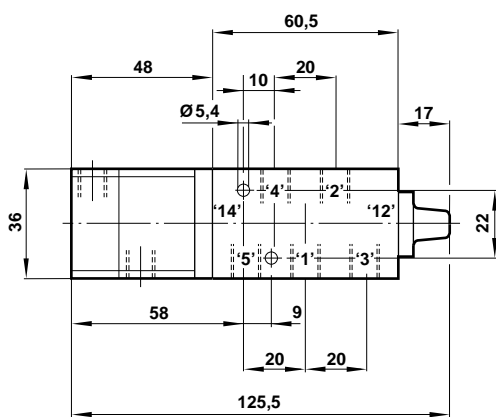

**G<sup>1</sup>/<sub>8</sub> X3 0475 03 Model**

**5/2 Diaphragm Servo, Pilot Return Valve**

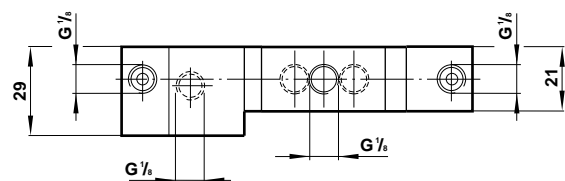
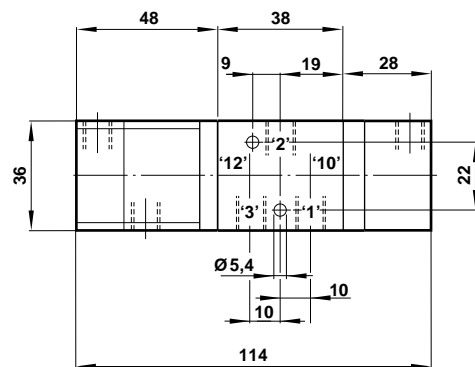

Valve should be mounted with the axis of the spool horizontal.



**G<sup>1</sup>/<sub>8</sub> X3 0473 03 Model**  
**5/2 Double Diaphragm (Servo) Valve**

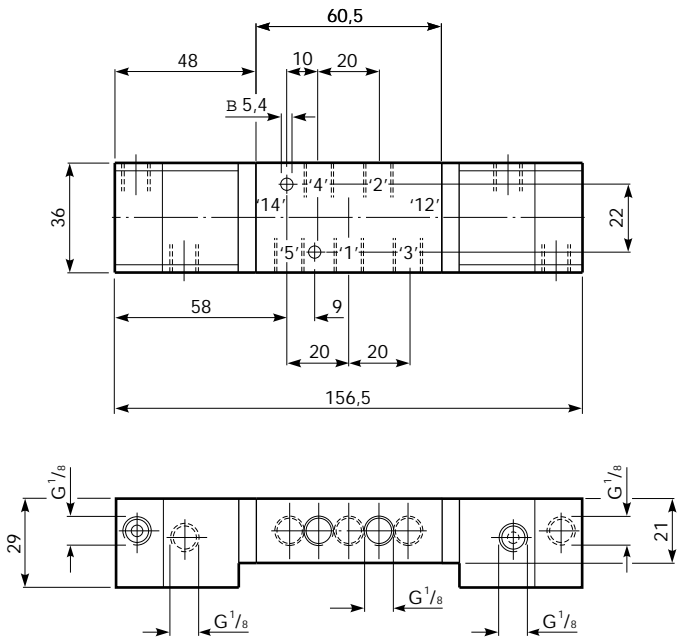

Valve should be mounted with the axis of the spool horizontal.

**G<sup>1</sup>/<sub>8</sub> X4 12\*2 & X4 17\*7 Models**  
**5/3 Double Solenoid, Spring Centralised Valves**

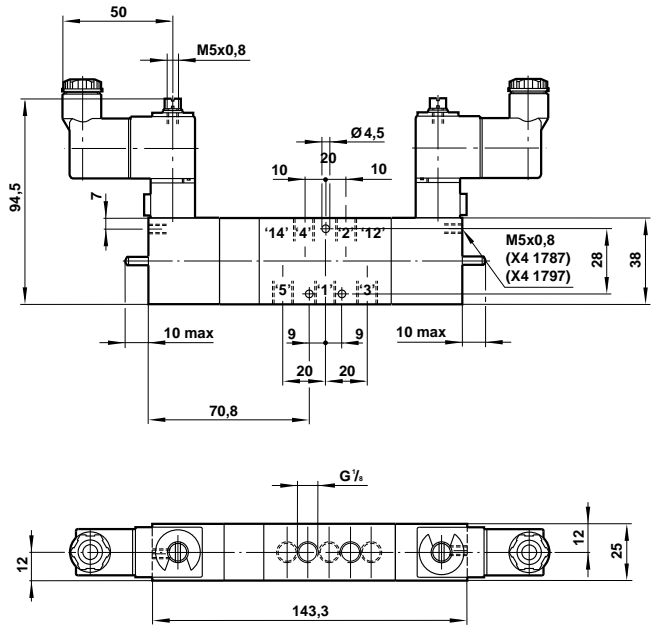

**G<sup>1</sup>/<sub>8</sub> X4 11\*1 & X4 16\*6 Models**  
**5/3 Double Solenoid, Spring Centralised Valves**

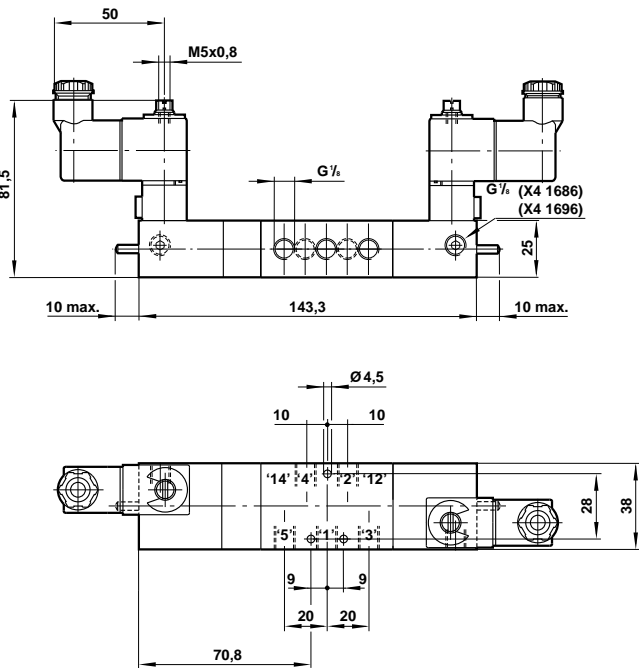

**G<sup>1</sup>/<sub>4</sub> 14 2235 & 14 2735 Models**  
**3/2 Single Solenoid Valves**

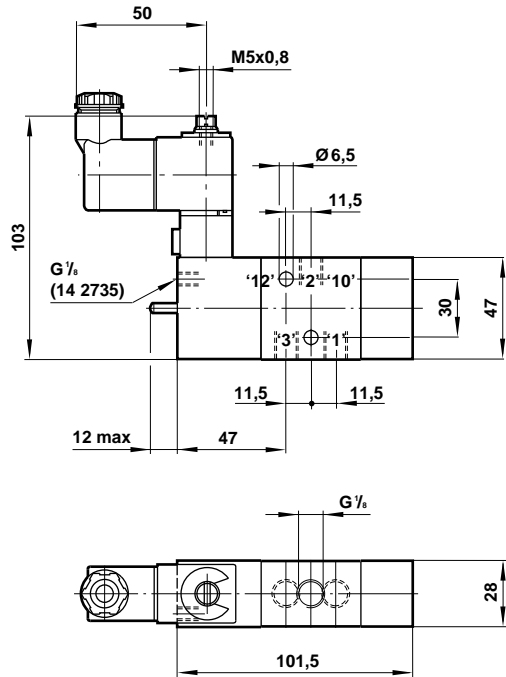







**G<sup>1</sup>/<sub>4</sub> 14 2538 Model  
3/2 Single Solenoid Valve**

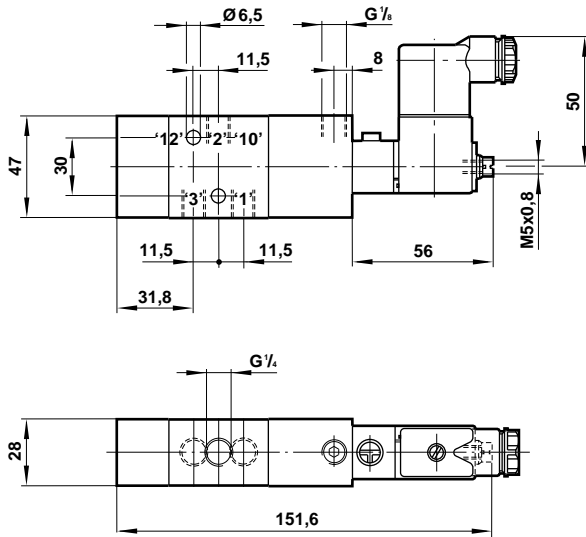

**G<sup>1</sup>/<sub>4</sub> 14 2234 & 14 2734 Models  
3/2 Single Solenoid Valves**

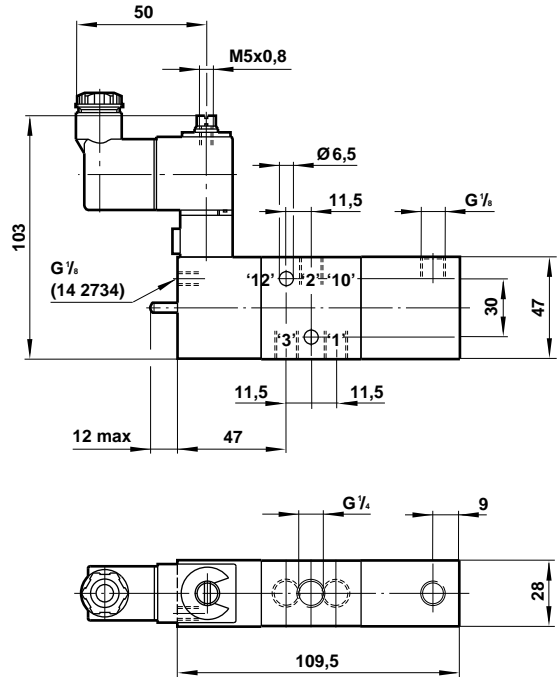

Valve should be mounted with the axis of the spool horizontal.

**G<sup>1</sup>/<sub>4</sub> 14 2432 & 14 2437 Models  
3/2 Single Solenoid Valves**

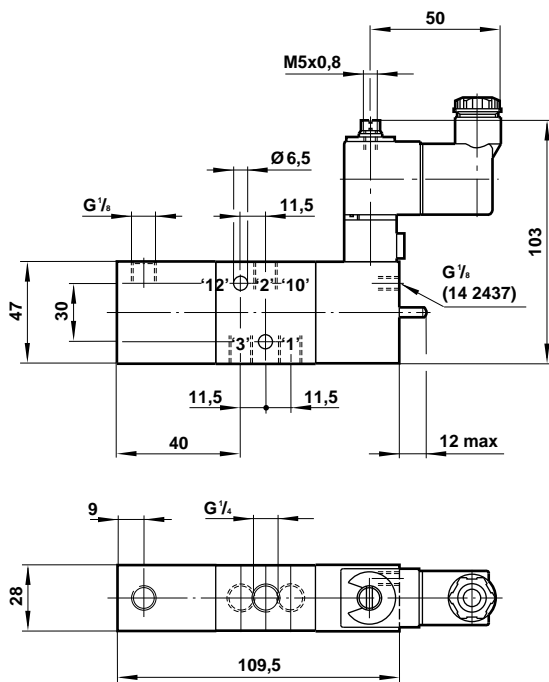

Valve should be mounted with the axis of the spool horizontal.

**G<sup>1</sup>/<sub>4</sub> 14 2134 & 14 2634 Models  
3/2 Solenoid Priority Set, Pilot Reset Valves**

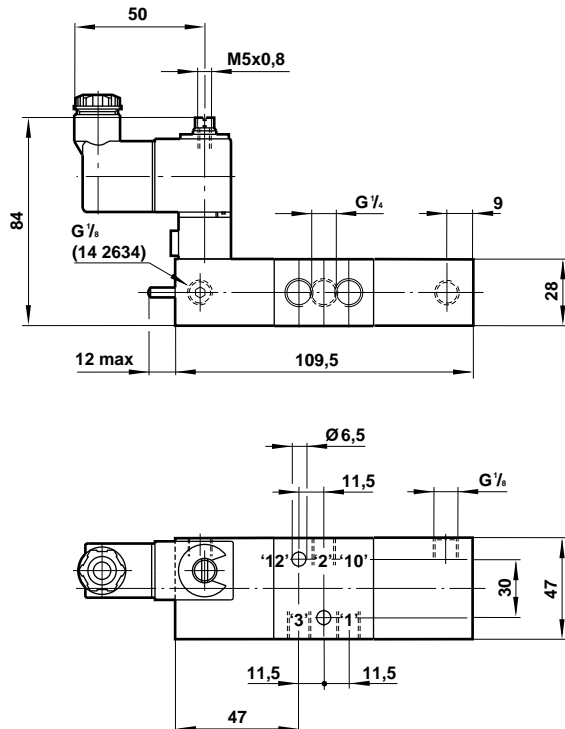

Valve should be mounted with the axis of the spool horizontal.



**G<sup>1</sup>/<sub>4</sub> 14 2431 & 14 2436 Models**  
**3/2 Solenoid Priority Set, Pilot Reset Valves**

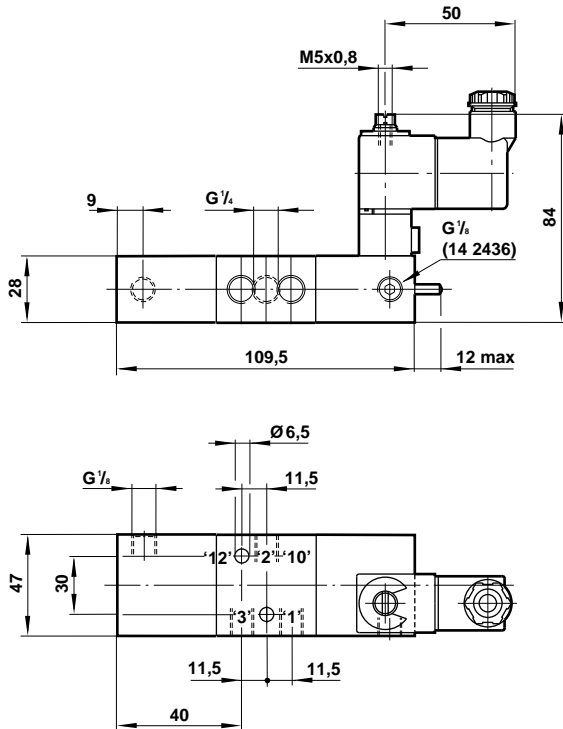

Valve should be mounted with the axis of the spool horizontal.

**G<sup>1</sup>/<sub>4</sub> 14 2834 Models**  
**3/2 Solenoid Priority Set, Pilot Reset Valves**

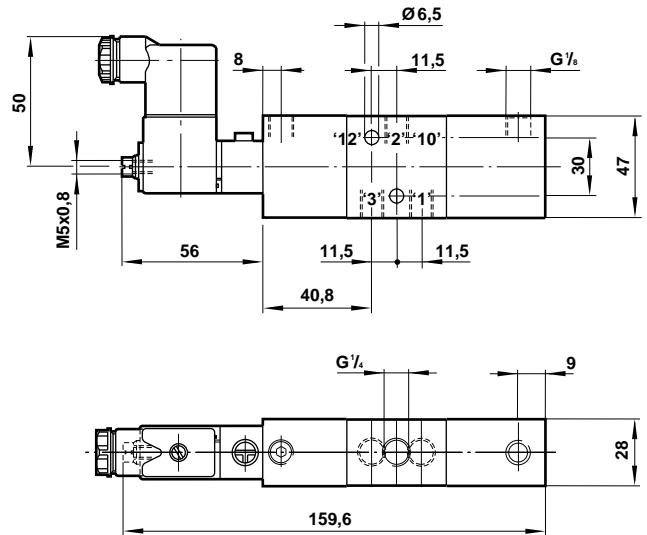

Valve should be mounted with the axis of the spool horizontal.

**G<sup>1</sup>/<sub>4</sub> 14 2838 Model**  
**3/2 Double Solenoid Valve**

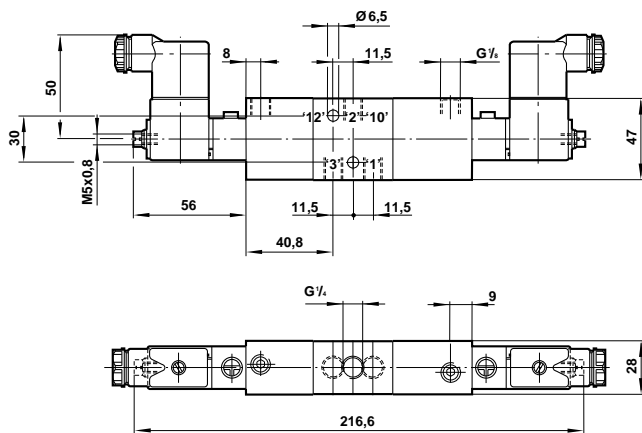

Valve should be mounted with the axis of the spool horizontal.

**G<sup>1</sup>/<sub>4</sub> 14 2232 & 14 2737 Models**  
**3/2 Double Solenoid Valves**

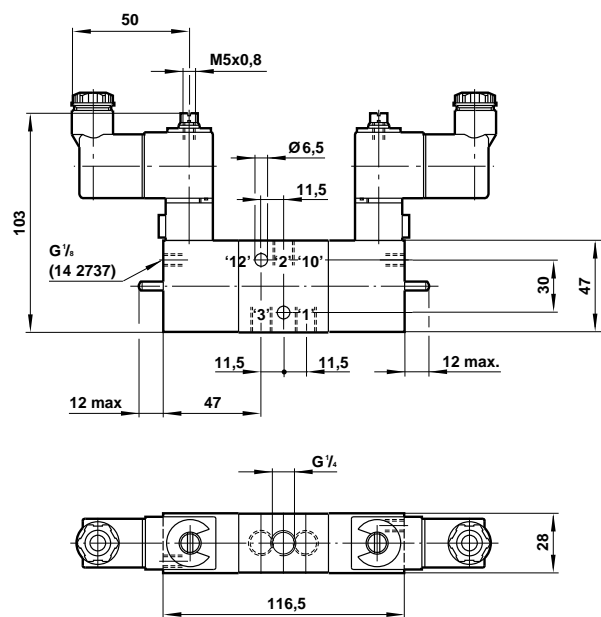

Valve should be mounted with the axis of the spool horizontal.



**G<sup>1</sup>/<sub>4</sub> 14 2131 & 14 2636 Models**  
**3/2 Double Solenoid Valves**

**G<sup>1</sup>/<sub>4</sub> 03 0601 02 & 03 0613 02 Models**  
**3/2 Single Pilot Valves**

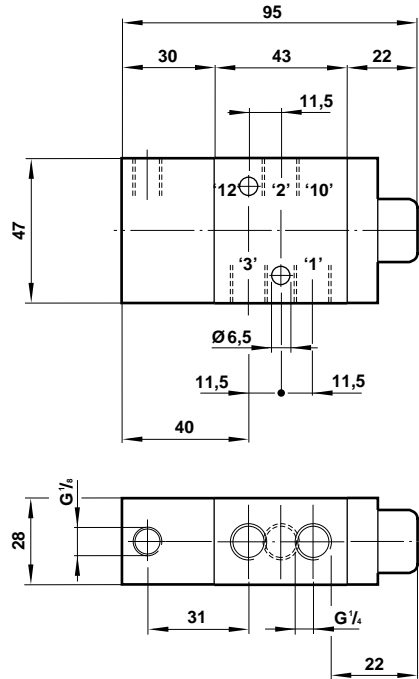
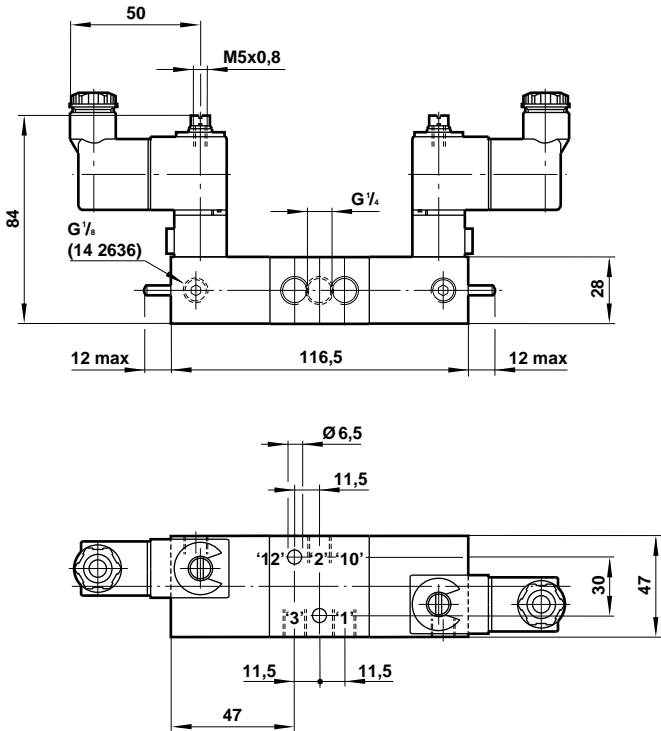

Valve should be mounted with the axis of the spool horizontal.

**G<sup>1</sup>/<sub>4</sub> 03 0607 02 Model**  
**3/2 Pilot Priority Valve**

**G<sup>1</sup>/<sub>4</sub> 03 0612 02 Model**  
**3/2 Double Pilot Valve**

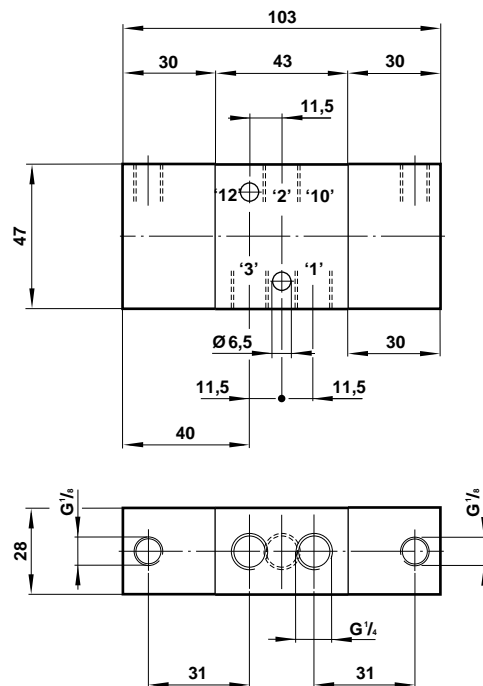
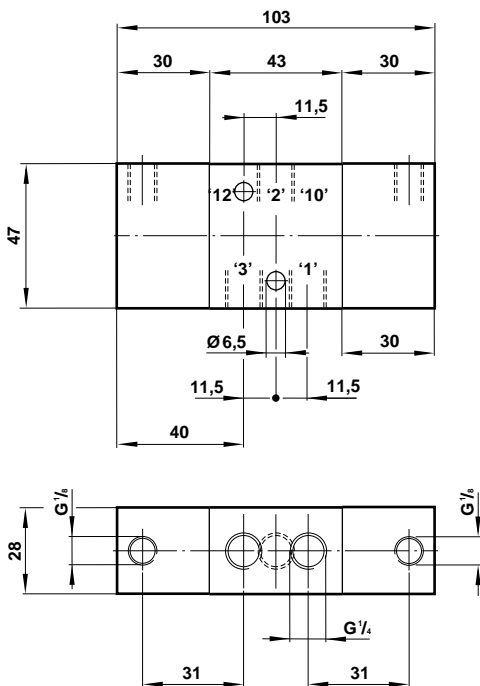

Valve should be mounted with the axis of the spool horizontal.

Valve should be mounted with the axis of the spool horizontal.



**G<sup>1</sup>/<sub>4</sub> X4 2255 & X4 2755 Models**  
**5/2 Single Solenoid Valves**

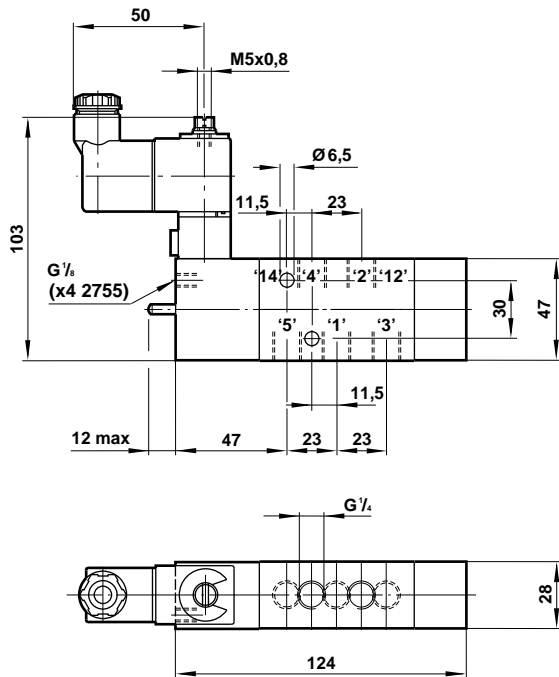

**G<sup>1</sup>/<sub>4</sub> X4 2155 & X4 2655 Models**  
**5/2 Single Solenoid Valves**

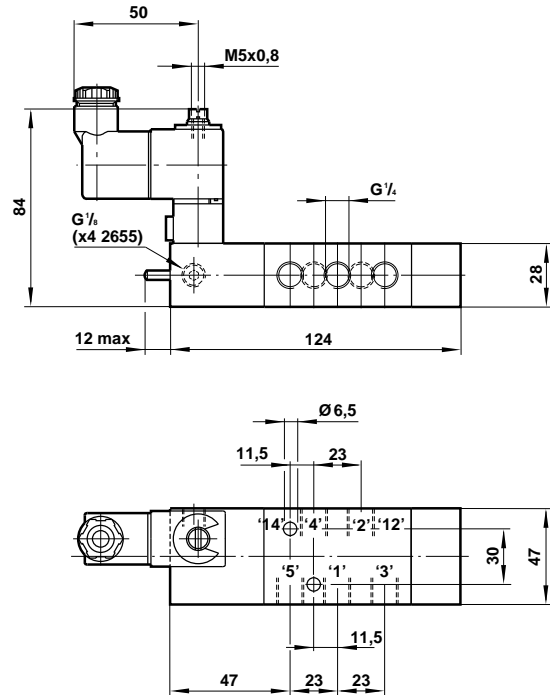

**G<sup>1</sup>/<sub>4</sub> X4 2855 & X4 9251 Models**  
**5/2 Single Solenoid Valve**

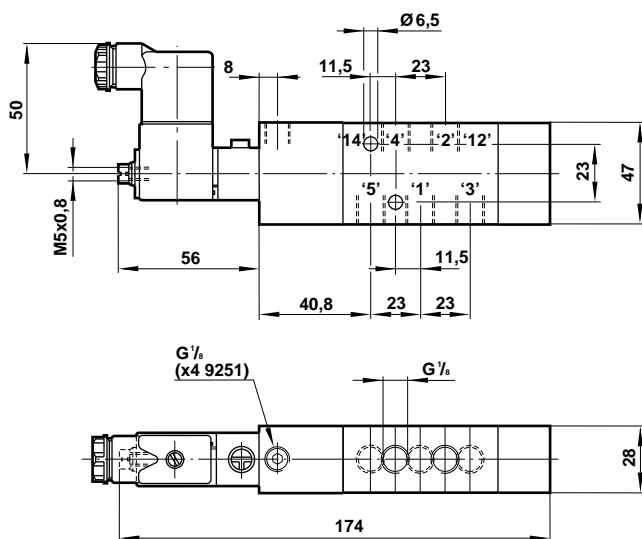

**G<sup>1</sup>/<sub>4</sub> X4 2254 & X4 2754 Models**  
**5/2 Solenoid Priority Set, Pressure Reset Valves**

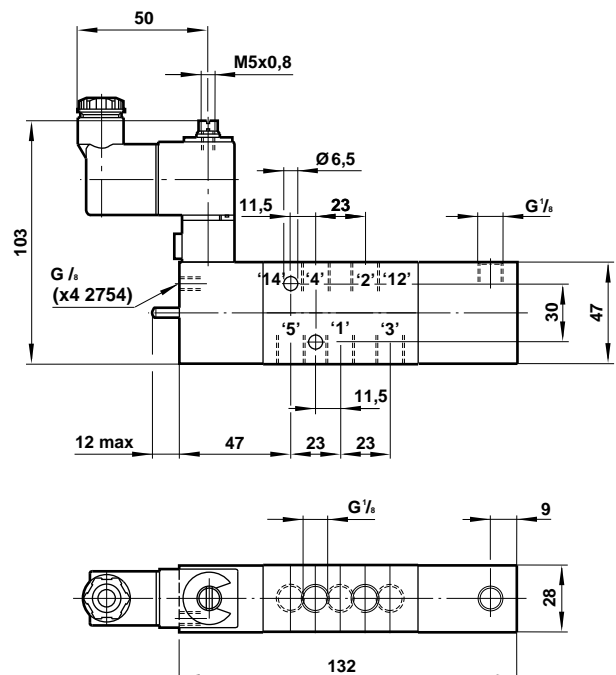

Valve should be mounted with the axis of the spool horizontal.



Super 'X'

**G<sup>1</sup>/<sub>4</sub> X4 2154 & X4 2654 Models**  
**5/2 Solenoid Priority Set, Pressure Reset Valves**

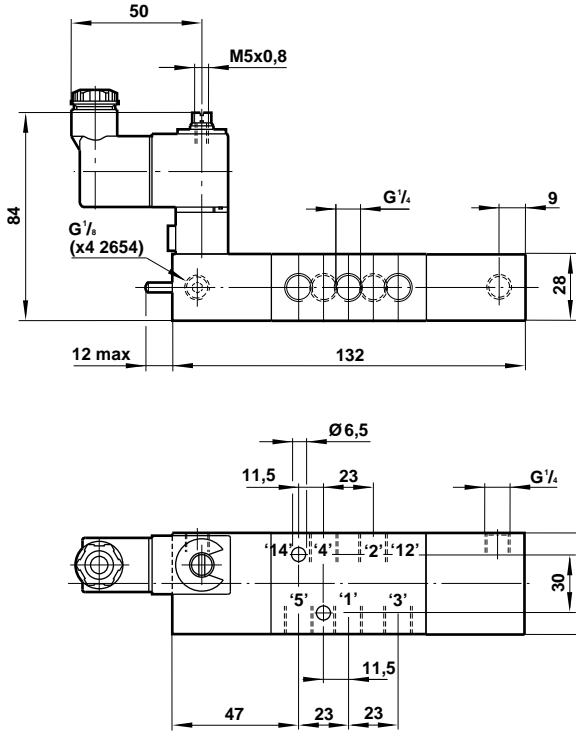

**G<sup>1</sup>/<sub>4</sub> X4 2854 Model**  
**5/2 Solenoid Priority Set, Pressure Reset Valve**

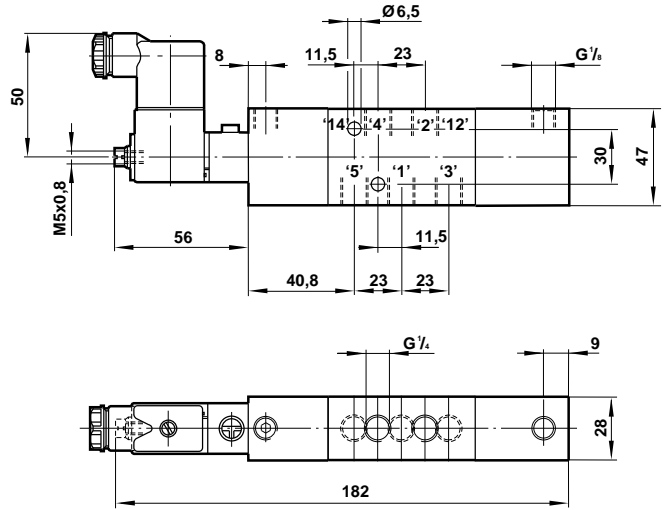

**G<sup>1</sup>/<sub>4</sub> X4 2858 & X4 9252 Models**  
**5/2 Double Solenoid Valves**

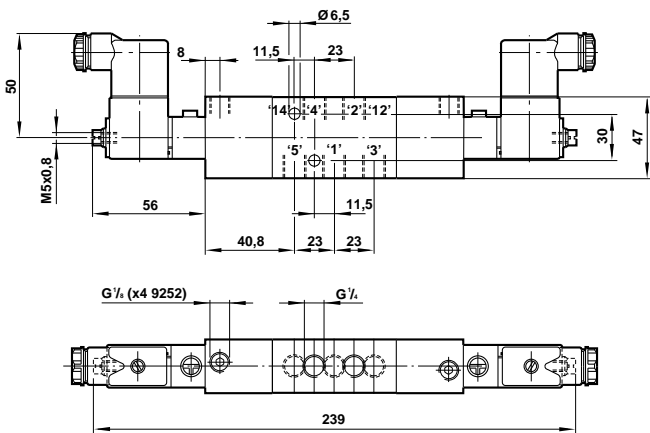

**G<sup>1</sup>/<sub>4</sub> X4 2252 & X4 2757 Models**  
**5/2 Double Solenoid Valves**

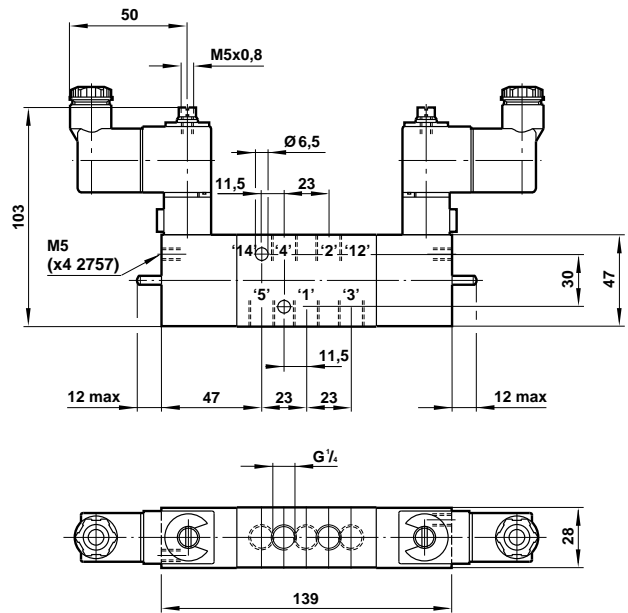

Valve should be mounted with the axis of the spool horizontal.

Valve should be mounted with the axis of the spool horizontal.



**G<sup>1</sup>/<sub>4</sub> X4 2151 & X4 2656 Models**  
**5/2 Double Solenoid Valves**

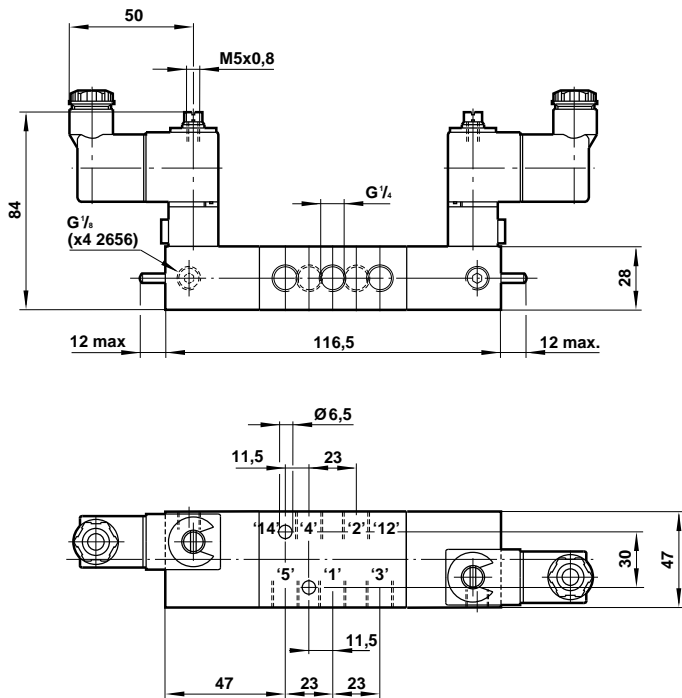

**G<sup>1</sup>/<sub>4</sub> X3 0641 02 Model**  
**5/2 Single Pilot Valve**

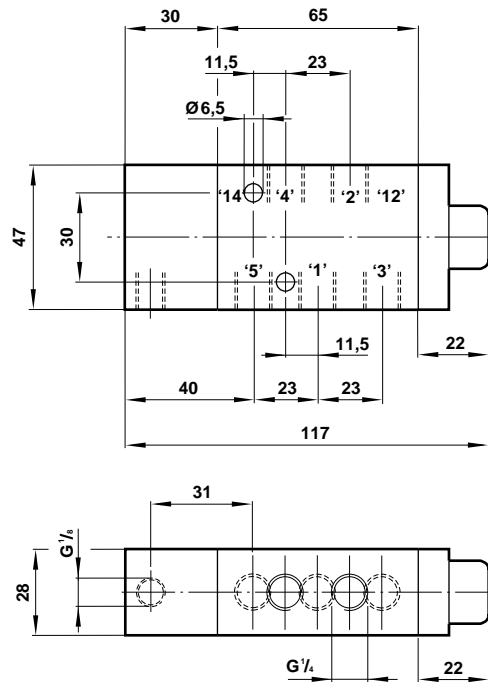

Valve should be mounted with the axis of the spool horizontal.

**G<sup>1</sup>/<sub>4</sub> X3 0647 02 Model**  
**5/2 Double Pilot Valve**

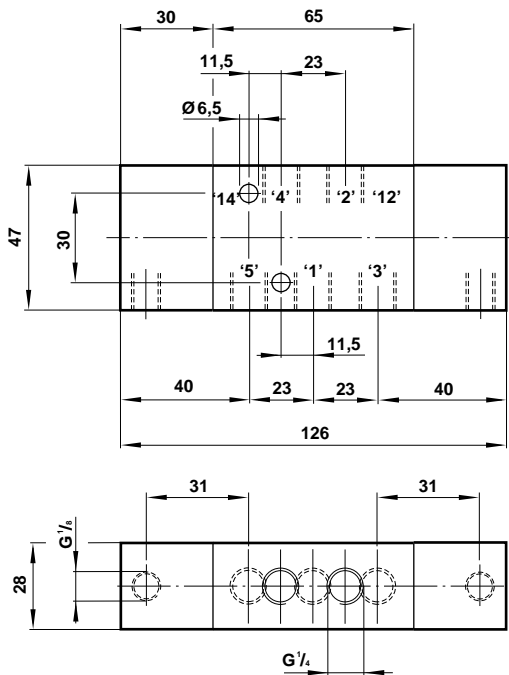

**G<sup>1</sup>/<sub>4</sub> X3 0652 02 Model**  
**5/2 Pilot Priority Valve**

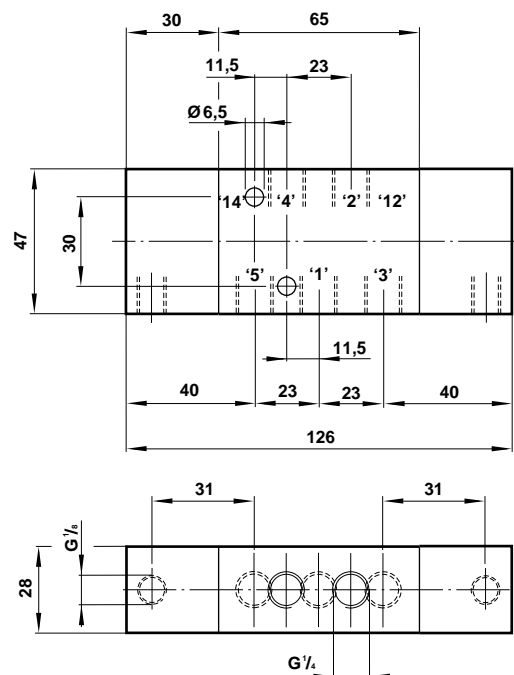

Valve should be mounted with the axis of the spool horizontal.

Valve should be mounted with the axis of the spool horizontal.



**G<sup>1</sup>/<sub>4</sub> X3 3607 & X3 3647 Models**  
**5/3 Double Pilot, Spring Centralised Valves**

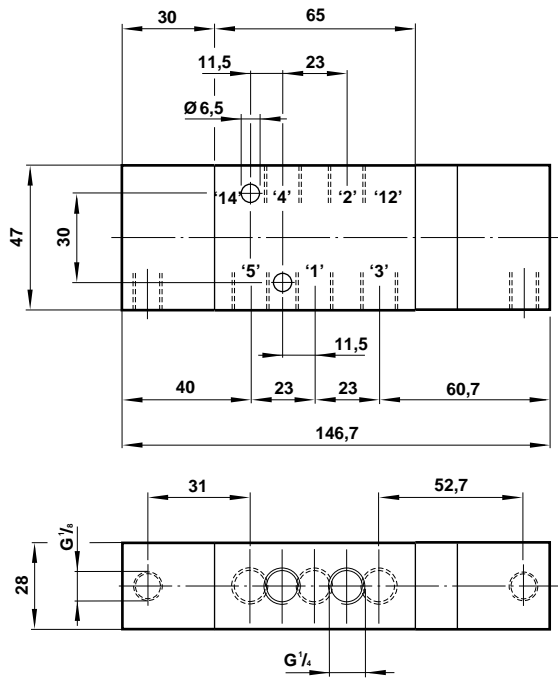

**G<sup>1</sup>/<sub>4</sub> X4 22\*2 & X4 27\*7 Models**  
**5/3 Double Solenoid, Spring Centralised Valves**

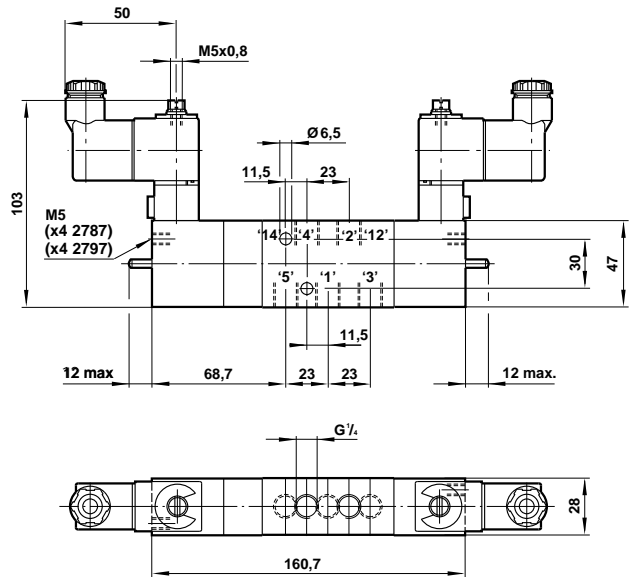

**G<sup>1</sup>/<sub>4</sub> X4 21\*1 & X4 26\*6 Models**  
**5/3 Double Solenoid, Spring Centralised Valves**

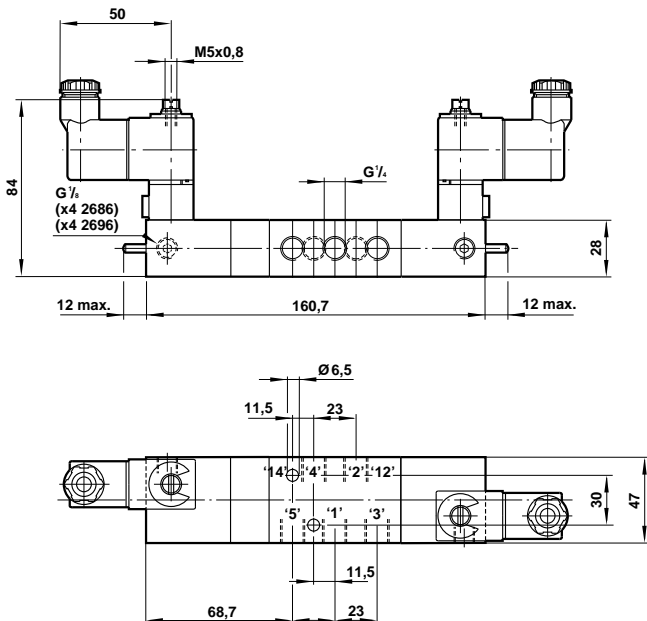

**G<sup>1</sup>/<sub>4</sub> X4 2888 & X4 2898 Models**  
**5/3 Double Solenoid, Spring Centralised Valves**

