

**In-line Mounted 5/2 Spool Valves  
Solenoid Actuated and Pilot Operated  
Ø 6 mm Push-In Fittings**

- 1 **High flow Bonded Spool technology**
- 1 **Compact dimensions with integral fittings**
- 1 **Low power solenoids with a range of voltages**
- 1 **Suitable for non-lubricated air supplies**

**Technical Data**
**Medium:**

Compressed air, filtered to 40µm, lubricated and non-lubricated

**Operation:**

Spool valve, indirectly actuated

**Mounting:**

Through-holes in valve body

**Port Size:**

6 mm o.d. Push-In Fittings

**Operating Pressure:**

Maximum 10 bar

See individual details overleaf

**Flow Characteristics:**

Size	'C'	'b'	'A'	l/min	Cv	Kv
Ø 6mm	1,57	0,26	6,28	394	0,4	0,36

**Ambient Temperature:**

-20°C to +80°C Pilot models

-20°C to +50°C Solenoid models

\*Consult our Technical Service for use below +2°C

**Materials**

Aluminium body, end caps and spool, bonded nitrile rubber seals.

**Ordering Information**

To order, quote model number and voltage code from tables overleaf, e.g. V106516A-B213A for a Solenoid Pilot Actuated, Spring and Air Return model fitted with a 24 V d.c. coil and screwdriver operated manual override.

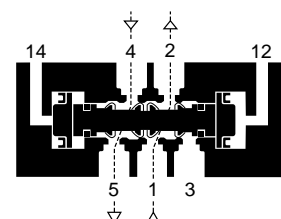
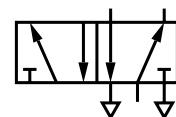



General Information

Symbol	Model	Manual Override	Solenoid Pilot	Operator	Return	Operating Pressure (bar)	Pilot Pressure (bar)	Weight (kg)	Spares kit
	V106516A-B21*A	Push and Lock	Internal	Solenoid	Spring and Air	3 – 10	–	0,155	V10035-K00
	V106516A-B31*A	Push Only							
	V106511A-B21*A	Push and Lock	Internal	Solenoid	Solenoid	2 – 10	–	0,198	V10035-K00
	V106511A-B31*A	Push Only							
	V106536A-X0130	–	–	Pressure	Spring and Air	2 – 10	1,5 + 0,5 x supply	0,152	V10035-K00
	V106533A-X0020	–	–	Pressure	Pressure	0 – 10	1 – 10	0,141	V10035-K00

\*Insert voltage code from table below.

\*Voltage Codes and Spare Coils

Voltage	Codes	Power Inrush/Hold	Coil Part Number
6V d.c.	1	1,5 W	V10025-A11
12V d.c.	2	1,7 W	V10025-A12
24V d.c.	3	1,7 W	V10025-A13
12V 50/60Hz	1	4,1/2,9 VA	V10025-A11
24V 50/60Hz	4	4,1/2,9 VA	V10025-A14
48V 50/60Hz	6	4,1/2,9 VA	V10025-A16
110V 50/60Hz	8	3,5/2,5 VA	V10025-A18
240V 50/60Hz	9	3,5/2,5 VA	V10025-A19

Electrical Details for Solenoid Operators

Voltage Tolerances:	±10%
Rating:	100% E.D.
Inlet Orifice:	0,8 mm
Electrical Connection:	DIN 43650 table 'C'
Manual Override:	V1065--A-B21*A – Push button, spring return with locking facility V1065--A-B31*A – Push button, spring return
Protection Class:	IP 65 (DIN 40050)

For details of connector plugs and light emitting seals see page 7.7.001

V106516A Models  
Single Solenoid Valves

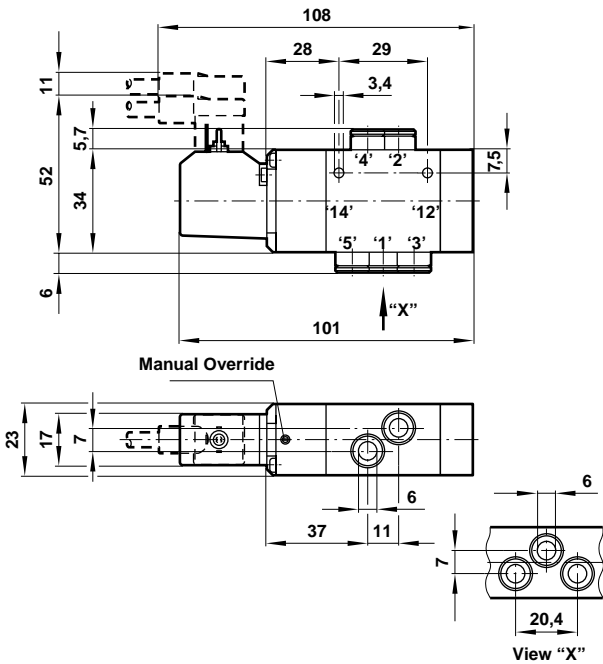

V106511A Models  
Double Solenoid Valves

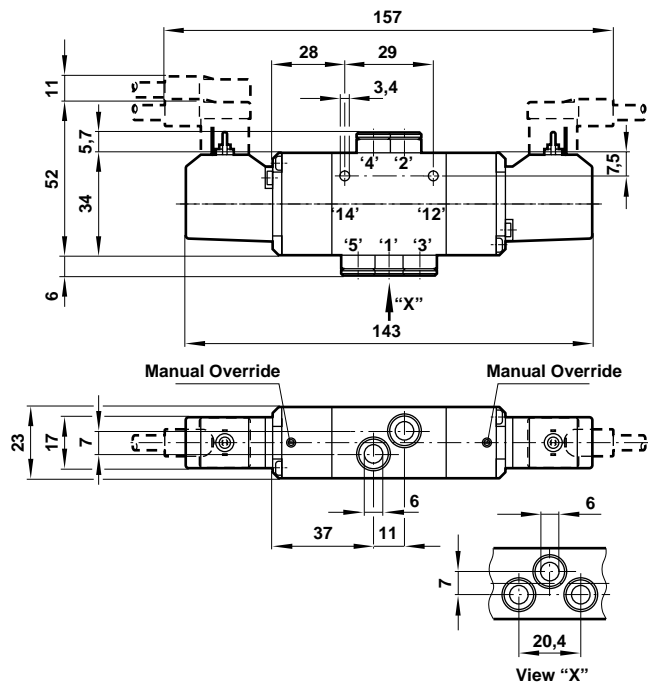



**V106536A-X0130**  
Single Pilot Valve

**V106533A-X0020**  
Double Pilot Valve

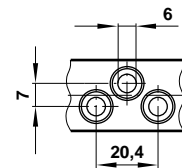
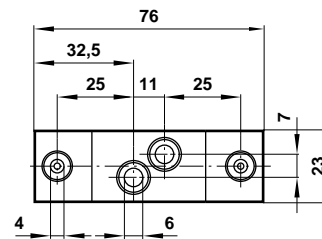
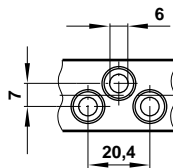
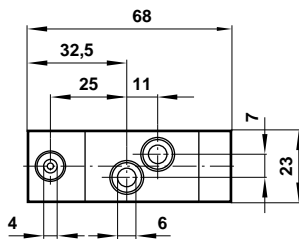
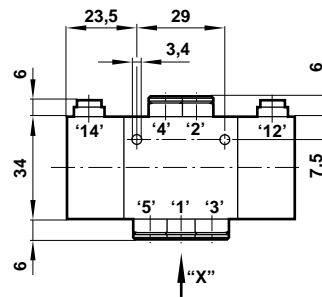
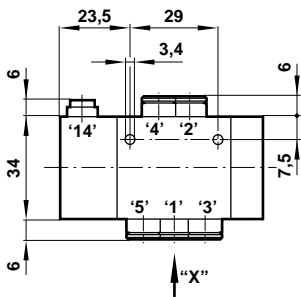

**Accessories**

Connector plugs and light emitting seals see page 7.7.001

**Warning**

These products are intended for use in industrial compressed air systems only. Do not use these products where *pressures* and *temperatures* can exceed those listed under **Technical Data**.  
 Before using these products with fluids other than those specified, for non-industrial applications, life-support systems, or other applications not within published specifications, consult NORGREN.  
 Through misuse, age, or malfunction, components used in fluid power systems can fail in various modes. The system designer is warned to consider the failure modes of all component parts used in fluid power systems and to provide adequate safeguards to prevent personal injury or damage to equipment in the event of such failure.  
**System designers must provide a warning to end users in the system instructional manual if protection against a failure mode cannot be adequately provided.**  
 System designers and end users are cautioned to review specific warnings found in instruction sheets packed and shipped with these products.