

- Very compact size
- In-line mounting
- Interchangeable operating head



3/2 Poppet Valves Pressure Actuated M5



Technical Data

Medium:

Compressed air, filtered, lubricated and non-lubricated

Operation:

Poppet valve, directly actuated

Mounting:

Through holes in valve body

Port Size:

M5

Operating Pressure:

0 - 10 bar

Flow (to CETOP RP50P):

'C' - Conductance $\text{dm}^3/\text{s}/\text{bar}$ 0,4

'b' - Critical pressure ratio 0,34

Cv 0,07

Operating Temperature:

0°C* to +70°C

*Consult our Technical Service for use below +2°C

Alternative Models

Other operator types for the 06 Series are also available:

Section 5.6. - Mechanically operated models

Section 5.7. - Manually operated models

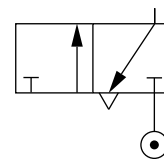

Materials

Diecast zinc alloy body, brass plunger, aluminium operator, acetal resin piston, stainless steel spring, nitrile rubber seals.

Ordering Information

To order a complete valve, quote model number 06 0205 00.

The basic body and operating head can also be ordered separately, quote model numbers overleaf.

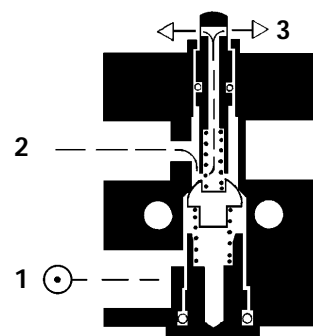



General Information

Model	Type	Operator	Return	Weight (kg)	Spares kit
06 0205 00	Normally closed	Pressure	Spring	0,09	Not available

Warning

These products are intended for use in industrial compressed air systems only. Do not use these products where *pressures* and *temperatures* can exceed those listed under 'Technical Data'.
 Before using these products with fluids other than those specified, for non-industrial applications, life-support systems, or other applications not within published specifications, consult NORGREN MARTONAIR.
 Through misuse, age, or malfunction, components used in fluid power systems can fail in various modes. The system designer is warned to consider the failure modes of all component parts used in fluid power systems and to provide adequate safeguards to prevent personal injury or damage to equipment in the event of such failure.
System designers must provide a warning to end users in the system instructional manual if protection against a failure mode cannot be adequately provided.
 System designers and end users are cautioned to review specific warnings found in instruction sheets packed and shipped with these products.

Pressure Actuated, Spring Return

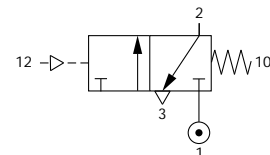

Model Number: **06 0205 00**

Type: 3/2 with open exhaust

Pilot Supply: 4 - 10 bar (If left under mains supply pressure of 8,5 bar for over 24 hours, initial break pressure 5 bar minimum.)

Basic Body: **06 0200 00**

Operating Head: **06 0005 00**

When fitting the operating head to the basic body, omit the face seal.

