



# Heavy Duty Flow Regulator M/600, C/600 Series

In line Flow Regulator 1/8", 1/4", 1/2"

- Panel mounted general purpose regulators
- Captive regulating needle will not blow out when unscrewed
- Calibrated adjusting knob, can be locked on G<sup>1/8</sup> and G<sup>1/2</sup> models
- Legend plate indicating direction of control supplied as standard
- High operating pressure



## Technical Data

Medium:

Compressed air, filtered, lubricated and non-lubricated

Operation:

Uni-directional

Mounting:

Panel mounted

Port Sizes:

	BSPP		NPT	
G <sup>1/8</sup>	S/636	1/8 NPT	C/636	
G <sup>1/4</sup>	M/637	1/4 NPT	C/637	
G <sup>1/2</sup>	M/639	1/2 NPT	C/639	

Operating Pressure:

0,3 - 16 bar

Operating Temperature:

-20°C\* to +80°C

\*Consult our Technical Service for use below +2°C

## Materials

Brass body, chromium plated adjusting knob, locking ring and panel mounting ring, nitrile rubber seals.

## Ordering Information

To order, quote model number from table overleaf, e.g. M/637 for the G<sup>1/4</sup> model

## Alternative models

M/800 range of Heavy duty flow regulators, see page 5.9.051.01

S/518 Precision flow regulators (air & hydraulic), see page 5.9.031.01

T1000 range of Block form flow regulators, see page 5.9.001.01

TM, TC/800 high temperature version (+150°C max.)

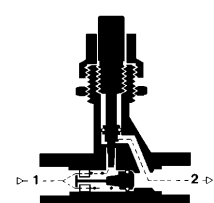
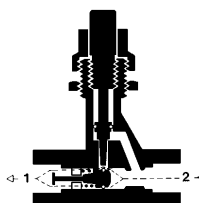
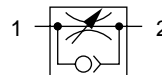



## General Information

MODEL		Type	Port Size	Weight (Kg)	Spares kit	
BSPP	NPT				BSPP	NPT
S/636	C/636	Uni-directional	1/8	0,13	QS/520/00	QC/520/00
M/637	C/637	Uni-directional	1/4	0,22	QS/521/00	QC/521/00
M/639	C/639	Uni-directional	1/2	0,78	QS/522/00	QC/522/00

BSPP = According to BS2779 and ISO - 228/1

NPT = Products are finished with National Pipe Straight Threads for Couplings, which are specifically designed to mate with NPT male threads

## Panel Mounted Flow Regulator

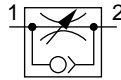
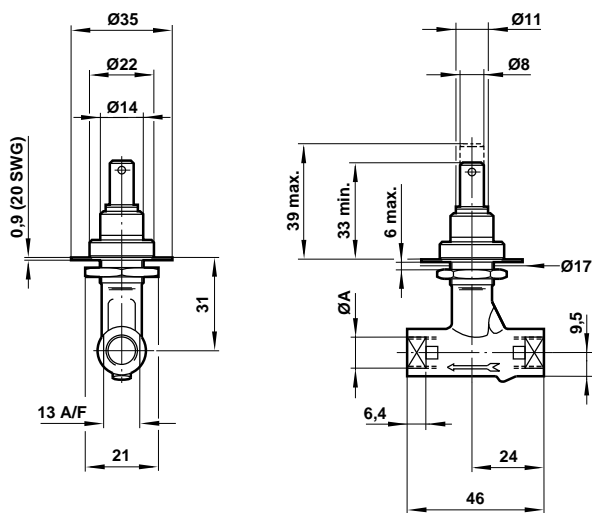

Model Number: **S/636**      ØA  
**C/636**                      G 1/8  
   1/8 NPT

Type: Uni-directional  
Free flow is from '2' to '1', indicated by arrow

## Panel Mounted Flow Regulator

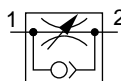
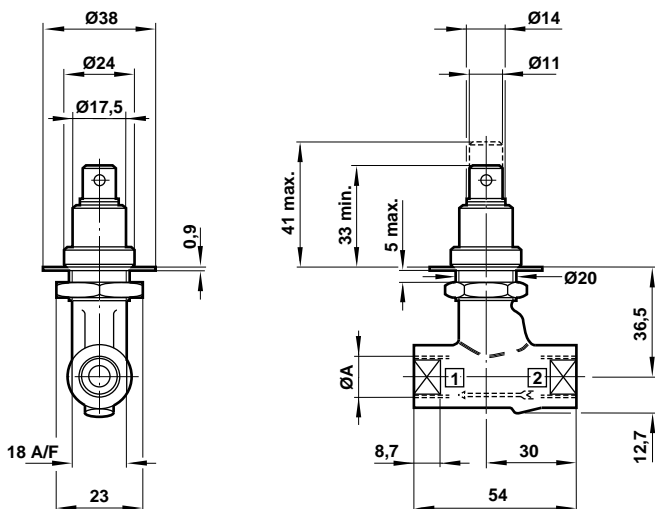

Model Number: **M/637**      ØA  
**C/637**                      G 1/4  
   1/4 NPT

Type: Uni-directional  
Free flow is from '2' to '1', indicated by arrow



Panel Mounted Flow Regulator

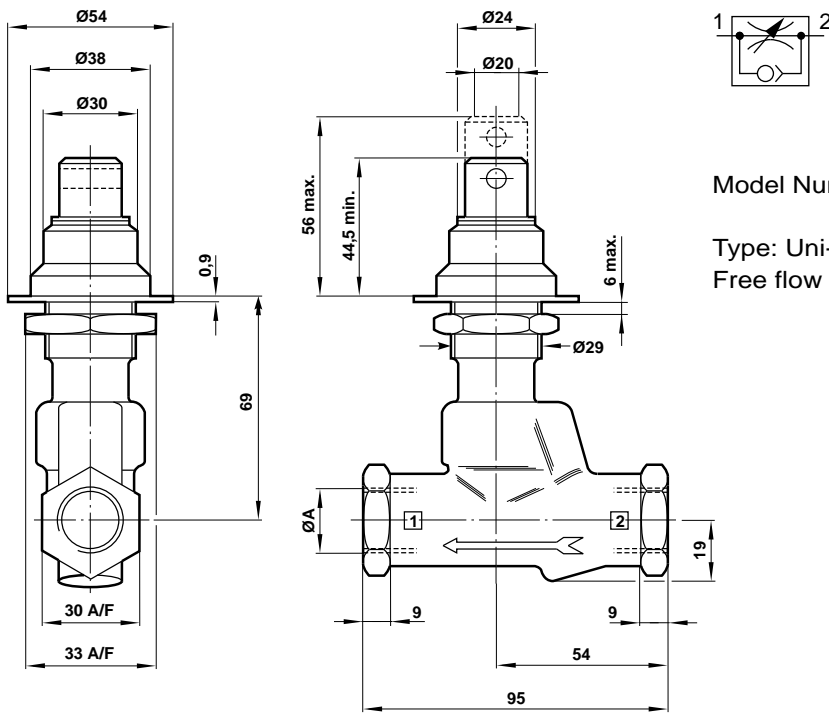

Model Number: **M/639**  $\varnothing A$   
**C/639** **G 1/2**  
**1/2 NPT**

Type: Uni-directional  
 Free flow is from '2' to '1', indicated by arrow

**Warning**

These products are intended for use in industrial compressed air systems only. Do not use these products where *pressures* and *temperatures* can exceed those listed under **'Technical Data'**.  
 Before using these products with fluids other than those specified, for non-industrial applications, life-support systems, or other applications not within published specifications, consult Norgren.  
 Through misuse, age, or malfunction, components used in fluid power systems can fail in various modes. The system designer is warned to consider the failure modes of all component parts used in fluid power systems and to provide adequate safeguards to prevent personal injury or damage to equipment in the event of such failure.  
**System designers must provide a warning to end users in the system instructional manual if protection against a failure mode cannot be adequately provided.**  
 System designers and end users are cautioned to review specific warnings found in instruction sheets packed and shipped with these products where applicable.