

- > Port size: G1/8
- > Light compact body
- > Air bleed principle
- > Exhaust port protected by filter disc
- > Low operation force - highly sensitive



Technical features

Medium:

Compressed air, filtered, lubricated and non-lubricated

Operation:

Poppet valves, bleed actuated

Operating pressure:

4 ... 10 bar (58 ... 145 psi)

Mounting:

Trough-holes in valve body

Port size:

G1/8

Ambient/Media temperature:

+5°C ... +80°C (+41 ... +176°F)

Materials:

Body : die-cast zinc alloy

Piston: steel

Seals: NBR

Technical data

Symbol	Port size	Function	Operator/return	Operating pressure (bar)	Operating force at 6 bar (N)	Flow (l/min)	Cv	Weight (kg)	Drawing No.	Model
	G 1/8	3/2	Plunger/air (internal supply)	4 ... 10	1	128	0,13	0,23	1	M/21/41
	G 1/8	3/2	Roller/air (internal supply)	4 ... 10	1	128	0,13	0,23	2	M/21/11
	G 1/8	3/2	Antenna/air (internal supply)	4 ... 10	0,15	128	0,13	0,23	3	M/21/70

Dimensions

Dimensions in mm
Projection/First angle

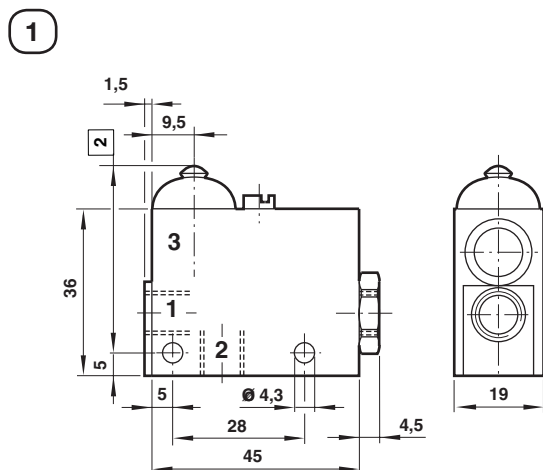

Pre-travel: 0,6 ... 3,3 mm
Operating Travel: 0,3 mm
Over-travel: 2,2 ... 3,9 mm

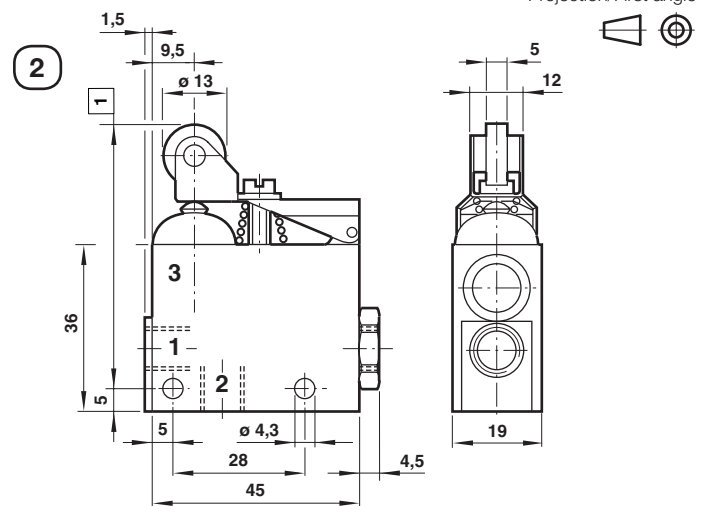

Pre-travel: 0,3 ... 1,0 mm
Operating Travel: 0,3 mm
Over-travel: 2,2 ... 3,9 mm

3

Dimensions in mm
Projection/First angle

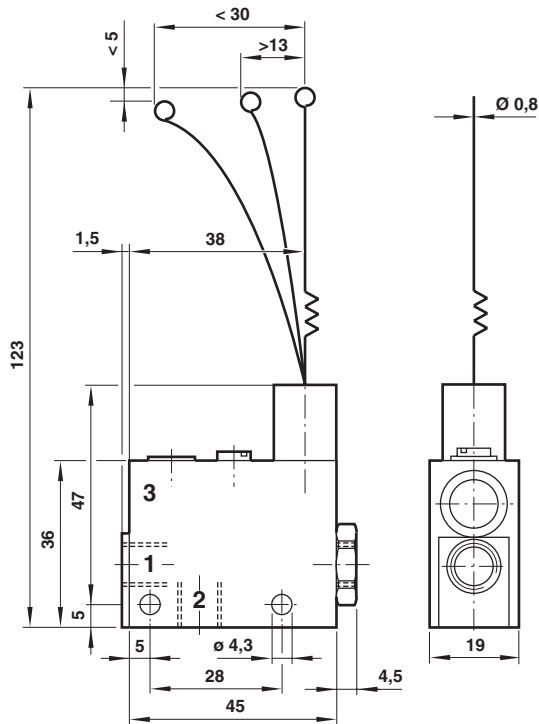

Warning

These products are intended for use in industrial compressed air systems only. Do not use these products where pressures and temperatures can exceed those listed under

»Technical features/data«.

Before using these products with fluids other than those specified, for non-industrial applications, life-support systems or other applications not within published specifications, consult IMI NORGREN.

Through misuse, age, or malfunction, components used in fluid power systems can fail in various modes.

The system designer is warned to consider the failure modes of all component parts used in fluid power systems and to provide adequate safeguards to prevent personal injury or damage to equipment in the event of such failure.

System designers must provide a warning to end users in the system instructional manual if protection against a failure mode cannot be adequately provided.

System designers and end users are cautioned to review specific warnings found in instruction sheets packed and shipped with these products.