

- Rugged, well proven range of valves
- Side ported, bottom ported and manifold sub-bases available
- Simple to service
- Explosion proof models available

Technical Data

Medium:

Compressed air, filtered, lubricated and non-lubricated

Operation:

Spool valve, indirectly actuated

Mounting:

Through holes in sub-base, threaded

Port Size:

G $\frac{1}{2}$

Operating Pressure:

2 - 10 bar M/1764/123, M/1744/7123

2.7 - 10 bar M/1764/152, M/1764/6123, M/1774/6123,

M/1744/7152, M/1744/8123, M/1754/8123

Flow (to CETOP RP50P):

Conductance dm 3 /s/bar 13,17

Critical pressure ratio 0,29

Operating Temperature:

+5°C to +50°C M/1764

-5°C* to +40°C supply air M/1744

+5°C to +40°C ambient M/1744

* Consult our Technical Service for use below +2°C

Materials

Pressure diecast zinc alloy body and sub-base, aluminium spool, steel and plastic centring mechanism, nitrile rubber seals

Ordering Information

To order, quote model number followed by voltage code from table overleaf, e.g. M/1764/123/137 for a Solenoid Pilot Set-reset model for use with an electrical supply of 220 - 240V 50/60Hz.

For manifold models, add number of valves required in manifold after 'T' suffix, e.g. CM/1764/123/137/T4 for four of the above models ready to be bolted together by means of tie rods supplied.

Spare valve bodies can also be supplied to assist servicing and reduce downtime by adding prefix 'Q' to the basic, side ported, valve number and '07' suffix, e.g. QM/1764/123/137/07.



5/2 and 5/3 Spool Valves
Solenoid Actuated
G $\frac{1}{2}$

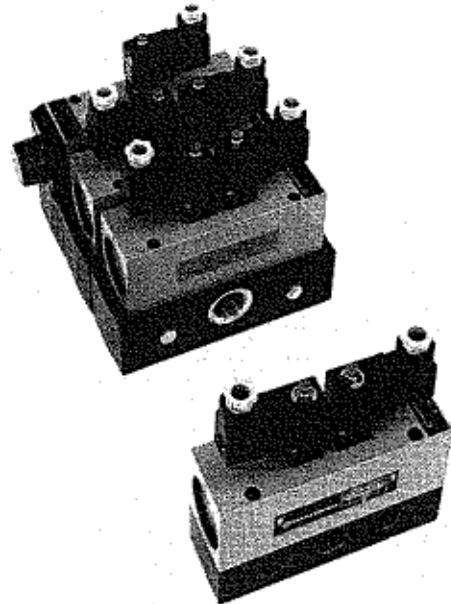

Alternative Models

Other operator types for the M/1764 and M/1774 range are also available:

Section 5.5. - Pressure actuated models (M/1704, M/1714)

Section 5.7. - Manually operated models (M/1704, M/1714)

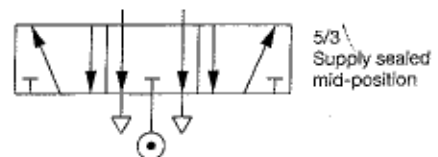
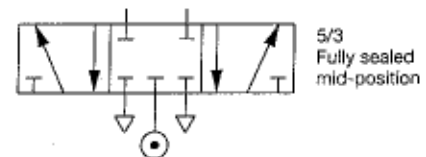
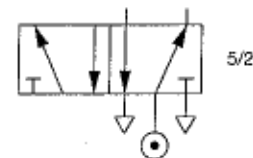



General Information

Model	Sub-base	Solenoid Pilot	Operator	Mid-position	Return	Weight (kg)	Spares kit
M/1764/152	Side ported	Integral	Solenoid	-	Air	2,42	QM/1704/00
M/1744/7152*	Side ported	Integral	Solenoid	-	Air	-	QM/1704/00
M/1764/123	Side ported	Integral	Solenoid	-	Solenoid	2,54	QM/1704/00
M/1744/7123*	Side ported	Integral	Solenoid	-	Solenoid	-	QM/1704/00
M/1764/6123	Side ported	Integral	Solenoid	Spring	Solenoid	2,54	QM/1704/00
M/1774/6123	Side ported	Integral	Solenoid	Spring	Solenoid	2,54	QM/1704/00
M/1744/8123*	Side ported	Integral	Solenoid	Spring	Solenoid	-	QM/1704/00
M/1754/8123*	Side ported	Integral	Solenoid	Spring	Solenoid	-	QM/1704/00
BM/1764/152	Bottom ported	Integral	Solenoid	-	Air	2,42	QM/1704/00
BM/1744/7152*	Bottom ported	Integral	Solenoid	-	Air	-	QM/1704/00
BM/1764/123	Bottom ported	Integral	Solenoid	-	Solenoid	2,54	QM/1704/00
BM/1744/7123*	Bottom ported	Integral	Solenoid	-	Solenoid	-	QM/1704/00
BM/1764/6123	Bottom ported	Integral	Solenoid	Spring	Solenoid	2,54	QM/1704/00
BM/1774/6123	Bottom ported	Integral	Solenoid	Spring	Solenoid	2,54	QM/1704/00
BM/1744/8123*	Bottom ported	Integral	Solenoid	Spring	Solenoid	-	QM/1704/00
BM/1754/8123*	Bottom ported	Integral	Solenoid	Spring	Solenoid	-	QM/1704/00
CM/1764/152/T	Manifold	Integral	Solenoid	-	Air	2,78	QM/1704/00
CM/1744/7152/T*	Manifold	Integral	Solenoid	-	Air	-	QM/1704/00
CM/1764/123/T	Manifold	Integral	Solenoid	-	Solenoid	2,90	QM/1704/00
CM/1744/7123/T*	Manifold	Integral	Solenoid	-	Solenoid	-	QM/1704/00
CM/1764/6123/T	Manifold	Integral	Solenoid	Spring	Solenoid	2,90	QM/1704/00
CM/1774/6123/T	Manifold	Integral	Solenoid	Spring	Solenoid	2,90	QM/1704/00
CM/1744/8123/T*	Manifold	Integral	Solenoid	Spring	Solenoid	-	QM/1704/00
CM/1754/8123/T*	Manifold	Integral	Solenoid	Spring	Solenoid	-	QM/1704/00

*Explosion proof solenoid models for use in Zones 1 and 2

Electrical Details for Solenoid Operators for M/1764 and M/1774

Voltage	Codes
6V d.c. (low power)	159
12V d.c. (low power)	160
12V d.c.	16
24V d.c. (low power)	127
24V d.c.	10
42 - 48V d.c.	157
48V d.c. (low power)	161
110V d.c (low power)	162
110 - 120V d.c	158
12V 50Hz (low power)	163
24V 50Hz (low power)	164
24V 50/60Hz	81
42 - 48V 50/60Hz	136
48V 50Hz (low power)	165
110V 50Hz (low power)	166
110 - 120V 50/60Hz	131
220V 50Hz (low power)	167
220 - 240V 50/60Hz	137

Voltage Tolerances:	d.c.: ±10% a.c.: +10/-15%
Inrush/Hold:	d.c.: 7W d.c.: 1.8W (low power - 2W on 24V, 3.4W on 110V) a.c.: 15/8VA a.c.: 4/2,5VA (low power - 9/5VA on 220V) 100% E.D.
Inlet Orifice:	1,6 mm 1,0 mm (low power)
Terminal Box:	3 pin plug with cable grip (DIN 43650 Form B) May be repositioned at 180°
Cable Entry:	Pg9
Solenoid Coil:	May be rotated at 90° intervals
Manual Override:	Standard, turn 180° anti-clockwise to operate, turn clockwise to return
Protection Class:	IP65 (DIN 40050)
Manual Override:	Standard, twist clockwise and hold to operate, release to return.

Electrical Details for Solenoid Operators for M/1744 and M/1754

Voltage	24V d.c. 220V 50/60Hz
Codes	10 156
Voltage Tolerances:	d.c.: ±10% a.c.: +10/-15%
Inrush/Hold:	d.c.: 5,7W a.c.: 17,5/10VA 100% E.D.
Cable:	6,6 mm o.d.
Conductors:	24/0,2-0,75 mm
Insulation:	PVC
Colours:	Brown, blue and green & yellow stripe (earth)
Test Certificate:	PTB Nr. Ex-79/2108 x
Protection rating:	E Ex e II T 4

The M/1744 models have been designed for use in potentially explosive atmospheres and comply with BS. 5501 Part 1-EN 50014 and BS. 5501 Part 6-EN 50019. They incorporate increased safety features over the standard solenoid, in the form of an explosion proof solenoid enclosure and terminal box, which have been applied so as to prevent, with a higher degree of security, the possibility of excessive temperatures and the occurrence of arcs or sparks in the interior and on the external parts of electrical apparatus which does not produce them normally. They are suitable for use in environments where the lowest ignition temperature of that atmosphere is above 135°C. They should not, however, be used in mines susceptible to firedamp. If there is a requirement for a valve to be used in a firedamp atmosphere (i.e. methane), then the JS/659 flameproof valve must be used. See page 5.4.091.01



Solenoid Pilot Actuated, Air Return

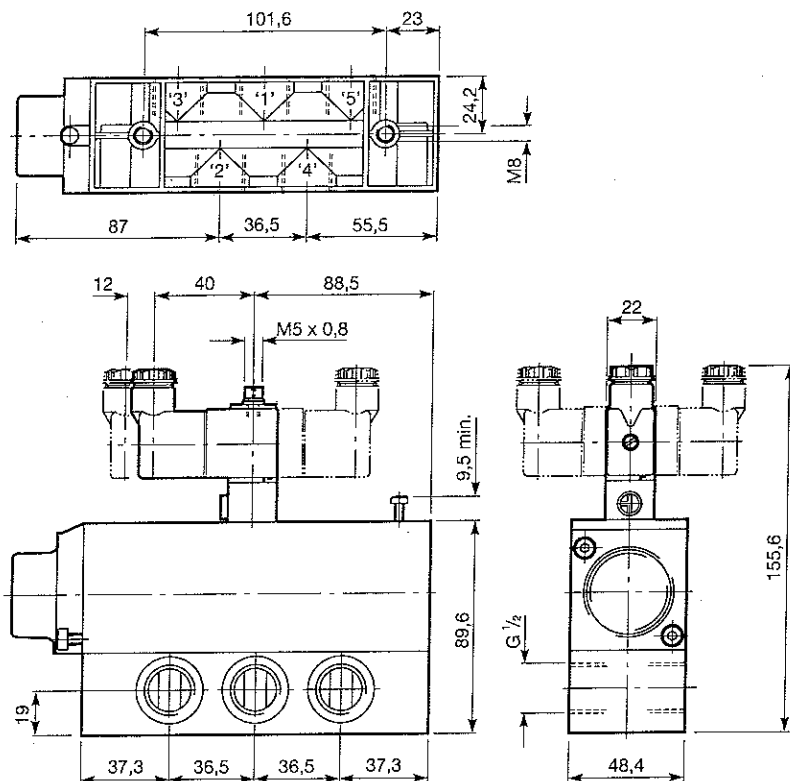

Model Number: **M/1764/152**

Type: 5/2

Integral Pilot Supply

Explosion Proof Solenoid Pilot Actuated, Air Return

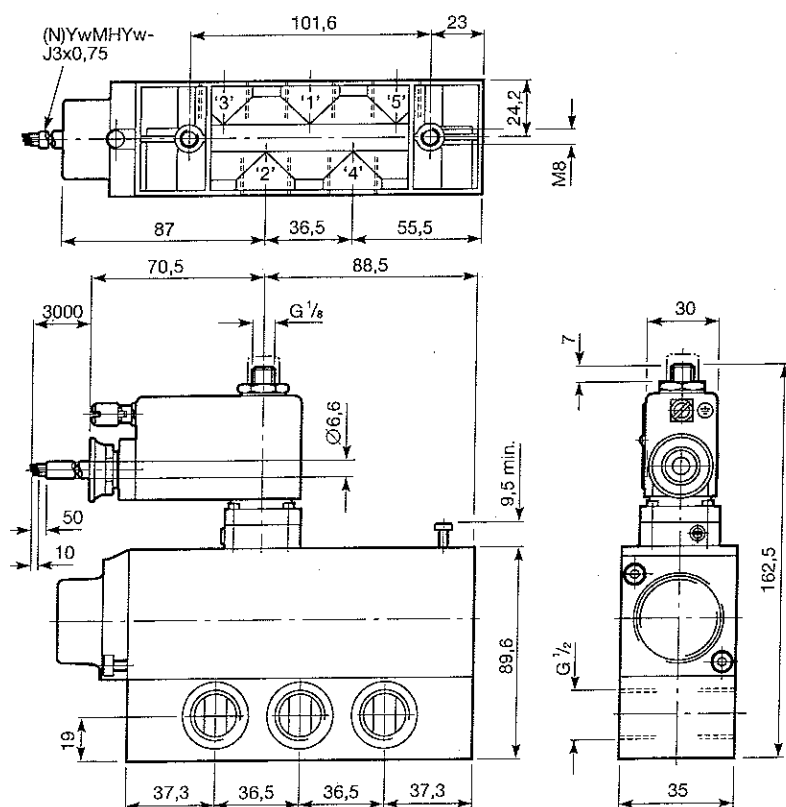

Model Number: **M/1744/7152**

Type: 5/2

Integral Pilot Supply



Spring Centralised Solenoid Pilot Actuated

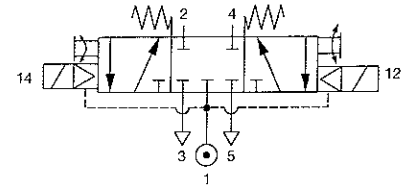
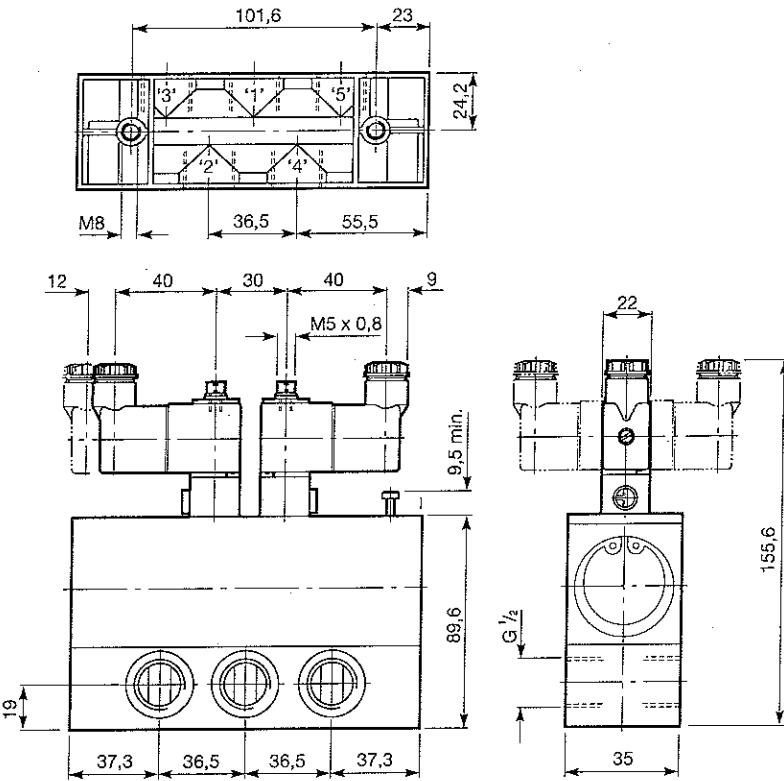

Model Number: **M/1764/6123**
 Type: 5/3 Fully sealed mid-position
 Integral Pilot Supply

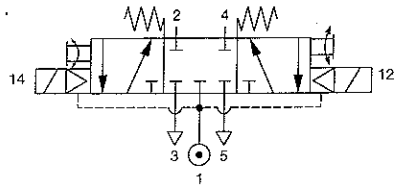

Model Number: **M/1774/6123**
 Type: 5/3 Supply sealed mid-position
 Integral Pilot Supply

Spring Centralised Explosion Proof Solenoid Pilot Actuated

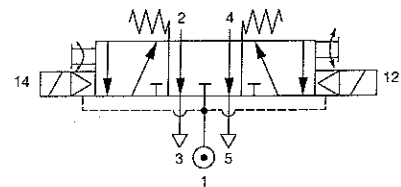
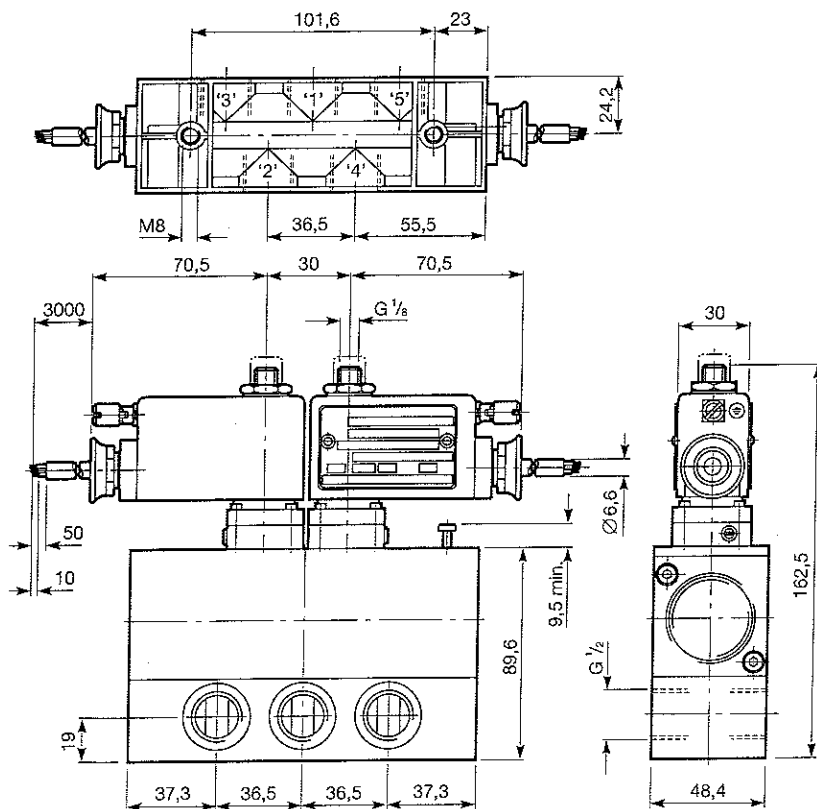

Model Number: **M/1744/8123**
 Type: 5/3 Fully sealed mid-position
 Integral Pilot Supply

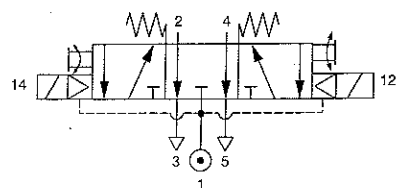

Model Number: **M/1754/8123**
 Type: 5/3 Supply sealed mid-position
 Integral Pilot Supply



Manifold Sub-base Models

- Model Numbers: **CM/1764/123/T***
CM/1764/152/T*
CM/1764/6123/T*
CM/1774/6123/T*
CM/1744/7123/T*
CM/1744/7152/T*
CM/1744/8123/T*
CM/1754/8123/T*

Type: Manifold sub-base with outlet and exhaust ports on the bottom and inlet port on the side for up to six valves.

*Insert number of valves required in manifold. Different models may be assembled in the same manifold. Plug for port '1' may be inserted at either end.

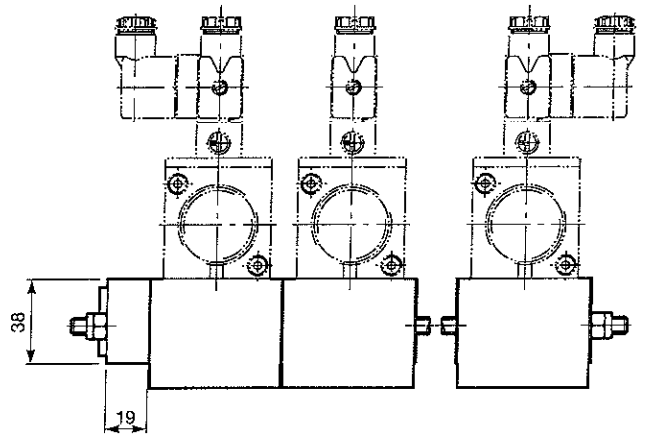
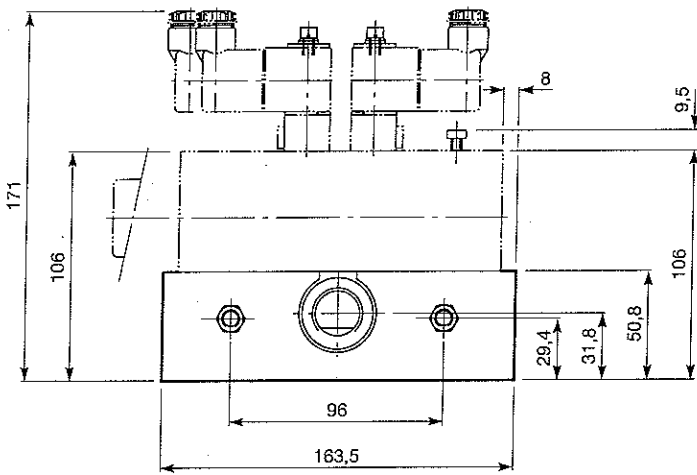
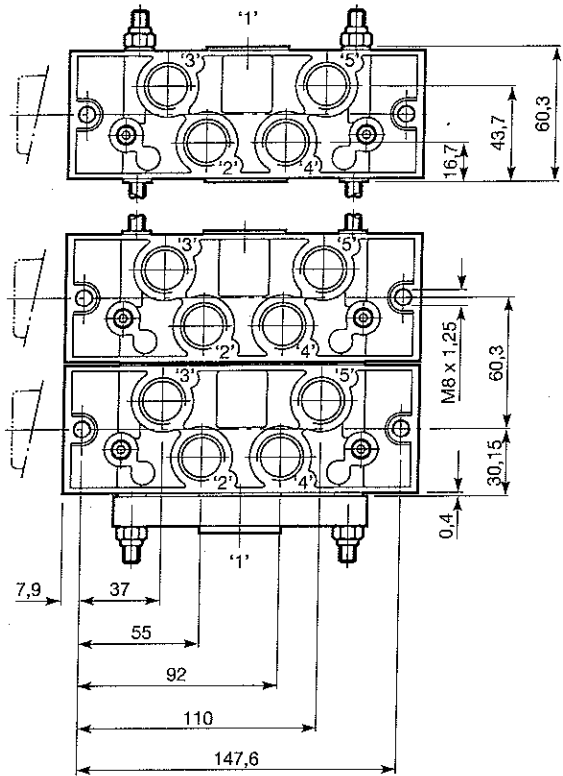



Accessories

Steel fixing plate, including screws and washers, is available for the side ported models, reference QM/1393.

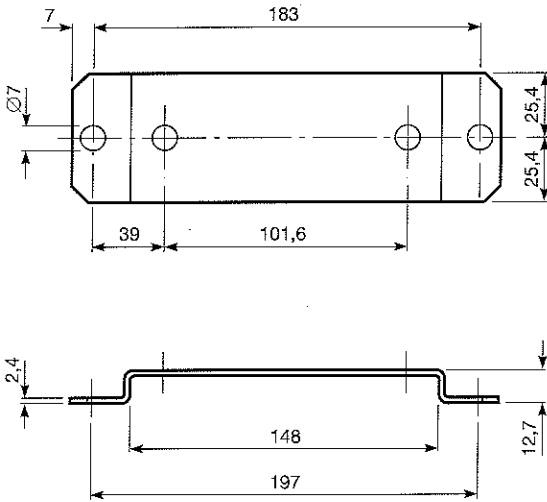

Warning

These products are intended for use in industrial compressed air systems only. Do not use these products where *pressures* and *temperatures* can exceed those listed under **'Technical Data'**.

Before using these products with fluids other than those specified, for non-industrial applications, life-support systems, or other applications not within published specifications, consult NORGREN MARTONAIR.

Through misuse, age, or malfunction, components used in fluid power systems can fail in various modes. The system designer is warned to consider the failure modes of all component parts used in fluid power systems and to provide adequate safeguards to prevent personal injury or damage to equipment in the event of such failure.

System designers must provide a warning to end users in the system instructional manual if protection against a failure mode cannot be adequately provided.

System designers and end users are cautioned to review specific warnings found in instruction sheets packed and shipped with these products.