

26360, 80207 NAMUR, 3/2, 5/2 & 5/3 Indirect solenoid actuated spool valves

- Port size: G 1/4 and NAMUR interface
- For single and double operated actuators
- Manual overrien with and without detent
- Simple design of soft seal spool system
- Easily interchangeable solenoid
- Maintenance-free
- All valves available with Ex protected coils (ATEX or other international approvals)



Technical features

Medium:
Compressed air, filtered, lubricated or non-lubricated

Operation:
Indirect solenoid operated T-spool valves

Operating pressure:
max. 10 bar (145 psi)
(see specifications)

Port size:
G 1/4

Flow direction:
Fixed

Mounting:
Optional, preferably with solenoid on top

Ambient/Media temperature:
-20° ... +60°C (-4° ... 140°F)
Depending on solenoid system
Air supply must be dry enough to avoid ice formation at temperatures below +2°C (+35°F).

Materials:
Housing: Aluminium anodised
Pilot flange: Plastic (POM)
Seals: NBR

Technical data

3/2 way

Symbol	Port size 1 & 3	2 & 3	Operating pressure (bar) min. max.	Flow (l/min)	Switching time (ms)	Manual override with/without detent	Weight without solenoid (kg)	Dimension No.	Model *1)
	G 1/4	Flange	1 10	1200	35	–	0,24	1	8020745
	G 1/4	Flange	1 10	1200	35	without	0,24	1	8020746
	G 1/4	Flange	1 10	1200	35	with	0,24	1	8020747

*1) When ordering, please indicate solenoid, voltage and current (frequency).

5/2 way valve

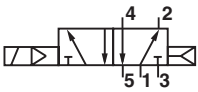
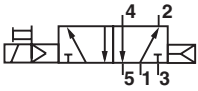
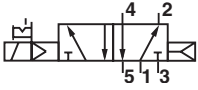
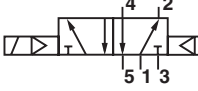
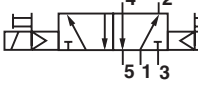
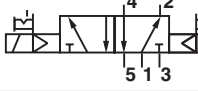
Symbol	Port size		Operating pressure (bar)		Flow (l/min)	Switching time (ms)	Manual override with/without detent	Weight without solenoid (kg)	Dimension No.	Model *1)
	1, 3 & 5	2 & 4	min.	max.						
	G 1/4	Flange	1	10	1200	35	-	0,55	2	2636045
	G 1/4	Flange	1	10	1200	35	without	0,55	2	2636046
	G 1/4	Flange	1	10	1200	35	with	0,55	2	2636047
	G 1/4	Flange	1	10	1200	30	-	0,90	3	2636245
	G 1/4	Flange	1	10	1200	30	without	0,90	3	2636246
	G 1/4	Flange	1	10	1200	30	with	0,90	3	2636247

5/3 way valve

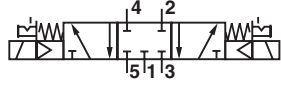
Symbol	Port size		Operating pressure (bar)		Flow (l/min)	Switching time (ms)	Manual override with/without detent	Weight without solenoid (kg)	Dimension No.	Model *1)
	1, 3 & 5	2 & 4	min.	max.						
	G 1/4	Flange	3	10	950	40	Mit	1,0	4	2636447

*1) When ordering, please indicate solenoid, voltage and current (frequency).

Solenoid operators

	Power consumption		Rated current		Protection class IP/NEMA	Ex-Protection (ATEX-Category)	Temperature Ambient/Media (°C)	Electrical connection	Drawing No.	Circuit diagram No.	Model
	24 V d.c. (W)	230 V a.c. (VA)	24 V d.c. (mA)	230 V a.c. (mA)							
	2,7	—	113	—	IP65 (with connector)	—	-25 ... +60 Fluid: max. +80	Connector DIN EN 175301-803 Form A *1)	1	1	0242
	—	4,2	—	18	IP65 (with connector)	—	-25 ... +60 Fluid: max. +80	Connector DIN EN 175301-803 Form A *1)	1	1	0245
	2,7	—	113	—	IP65 (with connector)	II 3G Ex nA IIC T5 Gc II 3D Ex tc IIIB T90°C Dc	-20 ... +60	Special connector DIN EN 175301-803 Form A	1	1	3215
	3,6	—	150	—	IP66	II 2G Ex mb IIC T4 Gb II 2D Ex mb IIIC T115°C Db	-20 ... +70	Cable length 3 m	5	4	0298
	—	5,3	—	18	IP66	II 2G Ex mb IIC T4 Gb II 2D Ex mb IIIC T115°C Db	-20 ... +70	Cable length 3 m	5	4	0299
	3,9	—	162	—	IP66 (with cable gland)	II 2G Ex eb mb IIC T4/ T6 Gb II 2D Ex tb IIIC T130°C Db	T4: -40 ... +80 T6: -40 ... +55 -40 ... +80	M20 x 1,5 *1)	6	4	4210
	—	5,3	—	23	IP66 (with cable gland)	II 2G Ex eb mb IIC T4/ T6 Gb II 2D Ex tb IIIC T130°C Db	T4: -40 ... +80 T6: -40 ... +55 -40 ... +80	M20 x 1,5 *1)	6	7	4211
	3,9	—	162	—	IP66 (with cable gland)	II 2G Ex d mb IIC T4/T6 Gb II 2G Ex e mb IIC T4/T6 Gb II 2D Ex tb IIIC T130°C Db	T4: -40 ... +80 T6: -40 ... +55 -40 ... +80	1/2 NPT *1)	7	20	4610
	—	5,3	—	23	IP66 (with cable gland)	II 2G Ex d mb IIC T4/T6 Gb II 2G Ex e mb IIC T4/T6 Gb II 2D Ex tb IIIC T130°C Db	T4: -40 ... +80 T6: -40 ... +55 -40 ... +80	1/2 NPT *1)	7	21	4611
	3,9	—	162	—	IP66 (with cable gland)	II 2G Ex d mb IIC T4/T6 Gb II 2G Ex e mb IIC T4/T6 Gb II 2D Ex tb IIIC T130°C Db	T4: -40 ... +80 T6: -40 ... +55 -40 ... +80	M20 x 1,5 *1)	7	20	4612
	—	5,3	—	23	IP66 (with cable gland)	II 2G Ex d mb IIC T4/T6 Gb II 2G Ex e mb IIC T4/T6 Gb II 2D Ex tb IIIC T130°C Db	T4: -40 ... +80 T6: -40 ... +55 -40 ... +80	M20 x 1,5 *1)	7	21	4613
	5,5	—	228	—	4x	Cl. I, Div. 1, Gr. A - D Cl. II/III, Div. 1, Gr. E - G T3C (160°C)	-20 ... +60	Flying leads length 460 mm	8	1	3722
	—	5,9	—	26	4x	Cl. I, Div. 1, Gr. A - D Cl. II/III, Div. 1, Gr. E - G T3C (160°C)	-20 ... +60	Flying leads length 460 mm	8	5	3723

Standard voltages ($\pm 10\%$) 24 V d.c., 230 V a.c., other voltages on request. Design according to VEn 0580, EN 50014/50028. 100% duty cycle.

*1) Connector is not scope of delivery, see table »Accessories«

Attention: The protection class for coil series 46xx and 48xx is determined by the choice of cable gland.

Example: if an ATEX-certified cable gland is used that has Ex d type of protection, the solenoid will have the protection class Ex d mb; if a cable gland with Ex e type of protection is used, the solenoid will have protection class Ex e mb.

Approvals

Model	Approvals			Datasheet
	ATEX	IECEX	FM	
029x	KEMA 02 ATEX 1347 X	—	—	N/en 71.505
321x, 381x	EC-Declaration of Conformity	—	—	N/en 71.570
372x, 382x	—	—	CSA-LR 57643-6	N/en 71.575
42xx	KEMA 98 ATEX 4452 X	IECEX KEM 09.0068X	—	N/en 71.580
46xx	PTB 02 ATEX 2085 X	IECEX PTB 11.0094X	—	N/en 71.585

Partnumbers for international approval

Land/Approval	Coil/Code	029x	321x	372x	42xx	46xx	48xx
Europa/ATEX	Standard	x	x	-	x	x	x
International/IECEX	Standard	x	x	-	x	x	x
China/NEPSI	-01	-	-	-	x	x	-
Brasilien/INMETRO	-02	-	-	-	x	x	-
Korea/KOSHA (only gas approval)	-03	-	-	-	x	x	x
Russland, Kasachstan & Weißrussland/TR-CU 012	-04	x	-	-	x	x	x
Indien/CCOE	Standard	-	-	-	x	x	-
Taiwan/ITRI	Standard	-	-	-	x	x	-
USA/FM	Standard	-	-	x	-	-	-
Kanada/CSA	Standard	-	-	x	-	-	-

Example: 000000421002400-04
(Coil: 4210; Voltage: 24V DC; Approval: TR-CU 012)

Accessories

Electrical connection



Cable gland
Protection class Ex e, Ex d (ATEX),
Nickel plated brass/
Stainless steel

Page 7

For solenoid	Thread	Cable Ø (mm)	Material	Protection class (ATEX)	Ambient temperatur limitation *1)	Model
42xx	M20 x 1,5	7,0 ... 12,0	Plastic	II 2G Ex e / II 2D Ex t	See table	0589735
42xx	M20 x 1,5	10,0 ... 14,0	Plastic	II 2G Ex e / II 2D Ex t	See table	0589736
42xx	M20 x 1,5	6,0 ... 12,0	Plastic	II 2G Ex e / II 2D Ex t	See table	0589737
42xx	M20 x 1,5	5,0 ... 10,0	Plastic	II 2G Ex e / II 2D Ex t	See table	0589739
46xx	M20 x 1,5	5,0 ... 8,0	Nickel plated brass	II 2G Ex e / II 2D Ex t	-	0588819
46xx	M20 x 1,5	10,0 ... 14,0	Nickel plated brass	II 2G Ex d / II 2D Ex t	-	0588851
46xx	1/2 NPT	7,5 ... 11,9	Nickel plated brass	II 2G Ex d / II 2D Ex t	-	0588925
46xx, 48xx	M20 x 1,5	9,0 ... 13,0	Stainless steel 1.4571	II 2G Ex e / II 2D Ex t	-	0589385
46xx, 48xx	M20 x 1,5	7,0 ... 12,0	Stainless steel 1.4404	II 2G Ex d / II 2D Ex t	-	0589395
46xx, 48xx	M20 x 1,5	10,0 ... 14,0	Stainless steel 1.4404	II 2G Ex d / II 2D Ex t	-	0589387

*1) The limitation of the temperature range to the mentioned range is due to the self-heating of the solenoid.

For solenoid	Ambient temperatur limitation solenoid 42xx		
	0589735 & 0589736 *2)	0589737	0589739 *2)
421x/426x	T4 & Dust Ex: -35°C ... + 80°C T6: -35°C ... + 55°C	T4 & Dust Ex: -40°C...+ 65°C T6: -40°C...+ 55°C	T4 & Dust Ex: -40°C...+ 78°C T6: -40°C...+ 55°C

*2) Tested for the lower level of mechanical risk (4 joule), an additional protection against impacts might be needed.

Accessories

Connector Form A	Silencer *1)	Exhaust guard *2)	Throttle control plate	Flange plate	Yoke	Distance plate for solenoids
0570275	Page 10 M/S2 (G1/4) C/S2 (1/4 NPT)	Page 10 0613422 (G1/4 or 1/4 NPT)	Page 9 4040239	Page 9 0612790 (NAMUR single connection plate) 0612791 (NAMUR-rip use in combination with 0612790, Alu)	Page 9 0540593	Page 9 0540109

*1) For indoors use

*2) For outdoors use, opening pressure ~ 0,2 bar

Dimensions Valves

Dimensions in mm
Projection/First angle



1

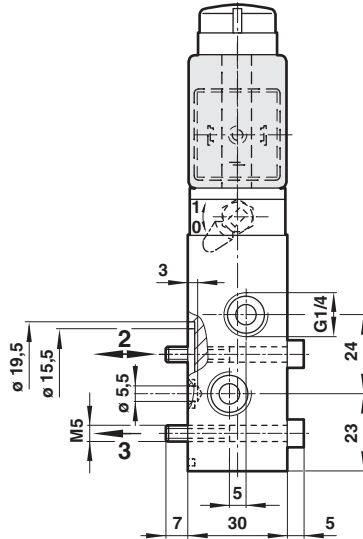
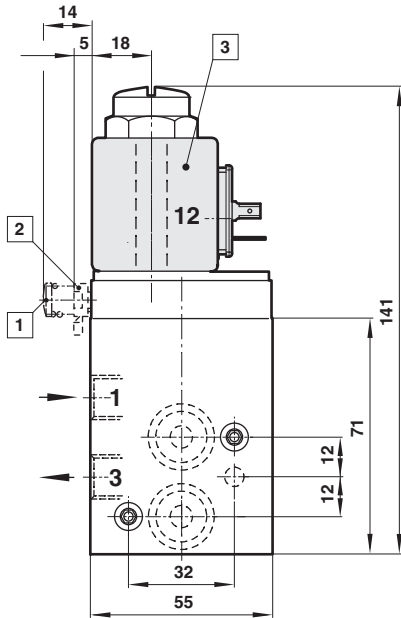

2

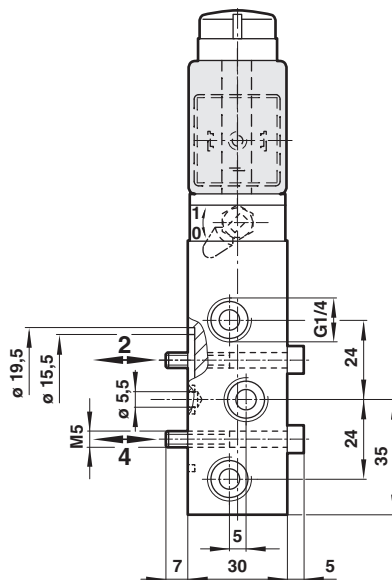
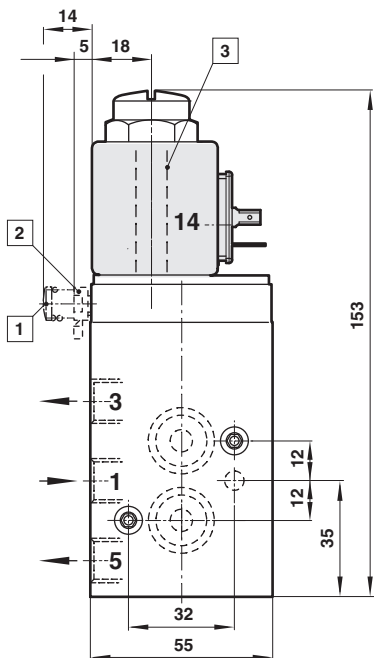

- 1 Manual overrien without detent
- 2 Manual overrien with detent
- 3 Solenoid 4 x 90° turnable

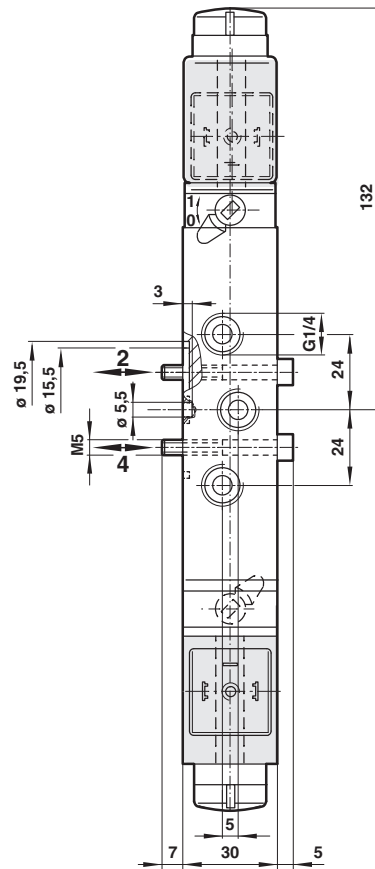
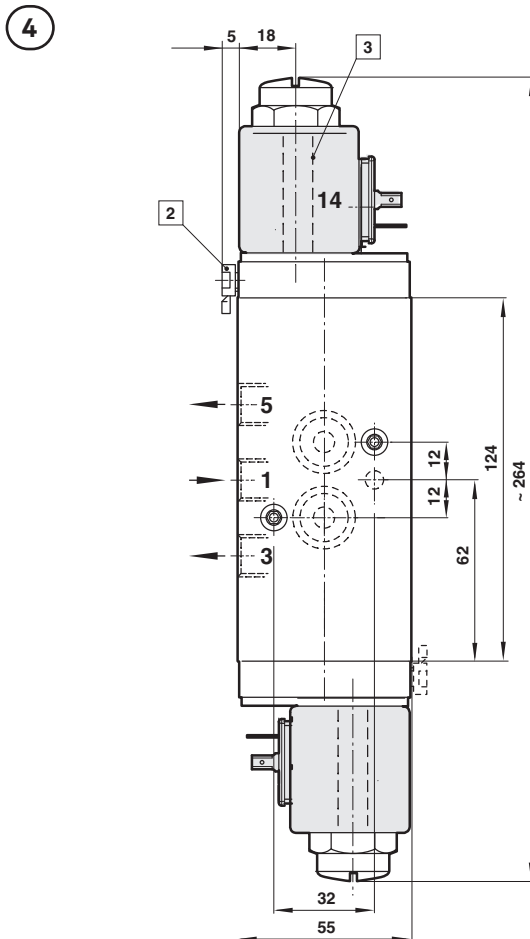
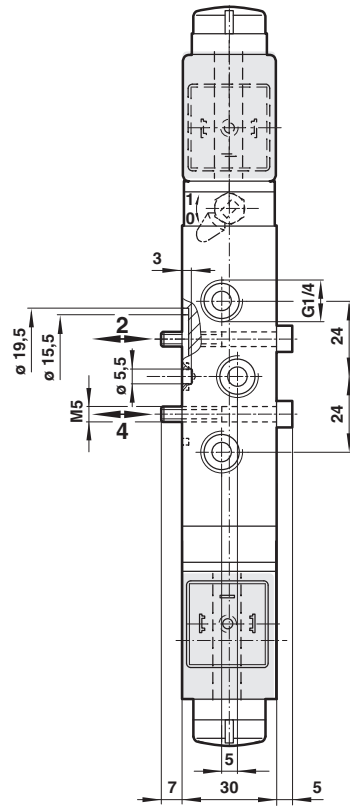
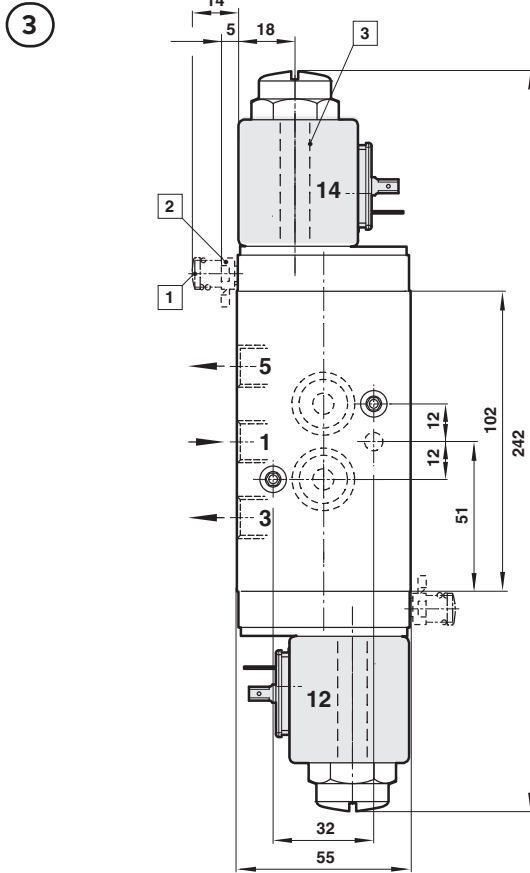

- 1 Manual overrien without detent
- 2 Manual overrien with detent
- 3 Solenoid 4 x 90° turnable

Dimensions Solenoid operators

Dimensions in mm
Projection/First angle



1 Weight: 0,15 kg

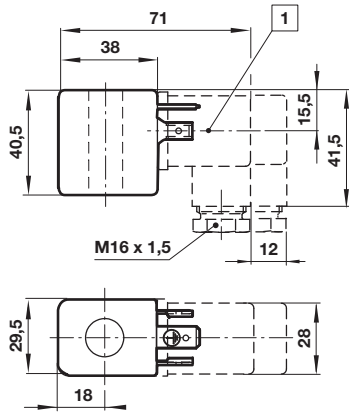

5 Weight: 0,5 kg

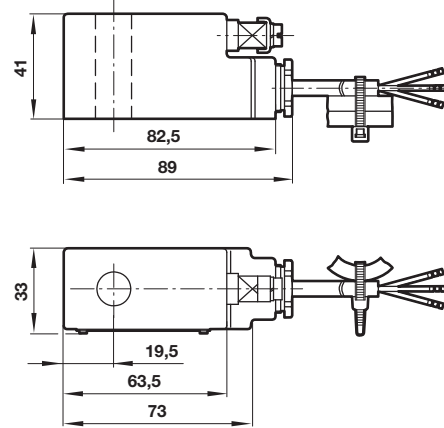

6 Weight: 0,4 kg

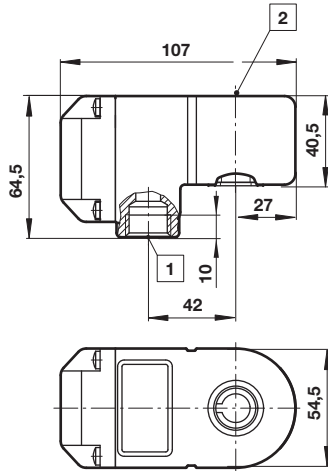

7 Weight: 0,8 kg

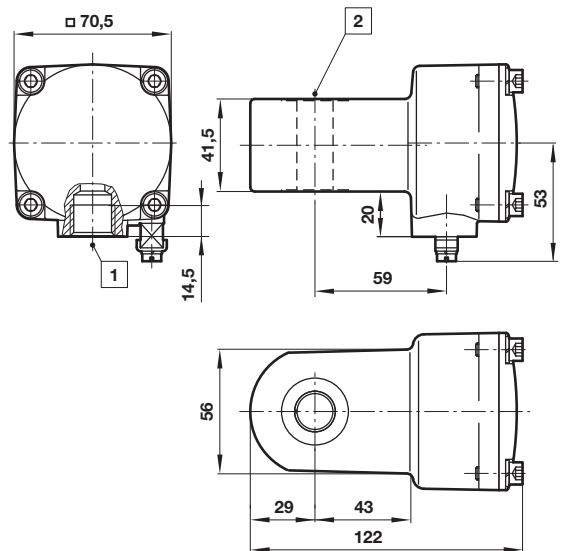

8 Weight: 0,5 kg

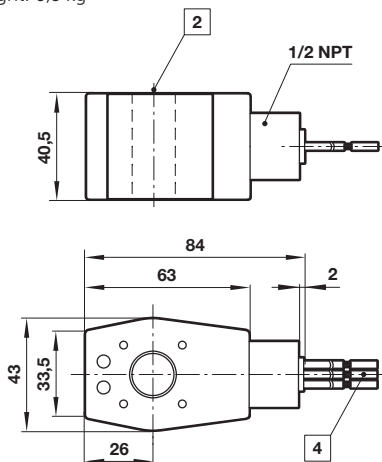

- 1** Connector can be indexed by 4x90°
- 2** Ø 16 or 13 (with spacer tube)
- 3** M20 x 1,5 or 1/2 - 14 NPT
- 4** Flying leads AWG 18 (460 mm long)

Circuit diagrams

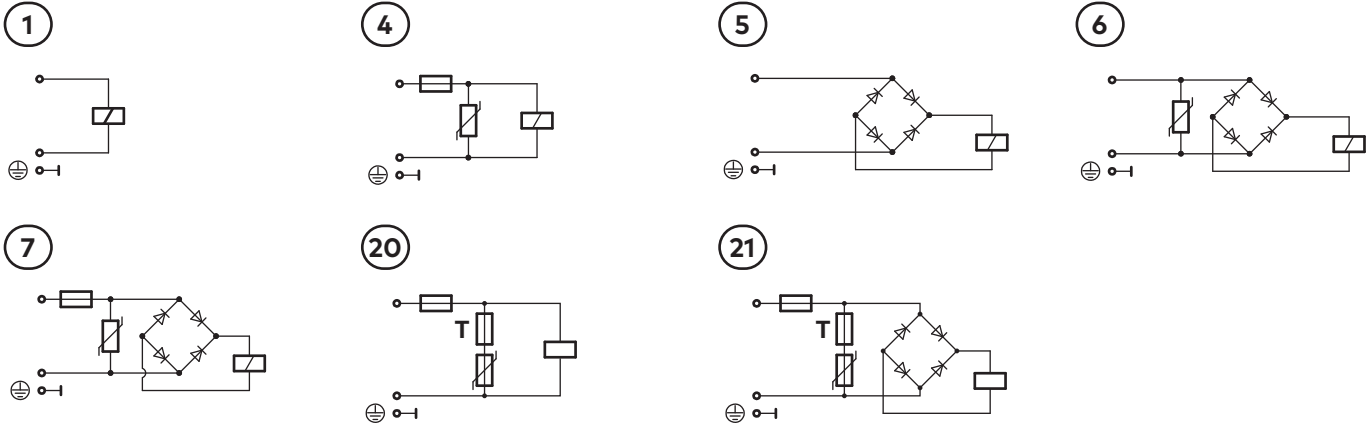

NAMUR hole pattern (actuator side)

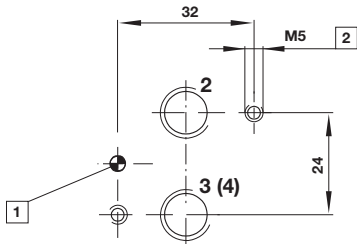

NAMUR quick exhaust module for a better kv-value by exhaust see data sheet 5.4.820

NAMUR interlinking plates in redundancy design for »safety exhausting« and »safety ventilating« see data sheet 5.4.830

- 1 Coding stud threaded
- 2 10 mm deep

Single connection plate

Type: 0612790

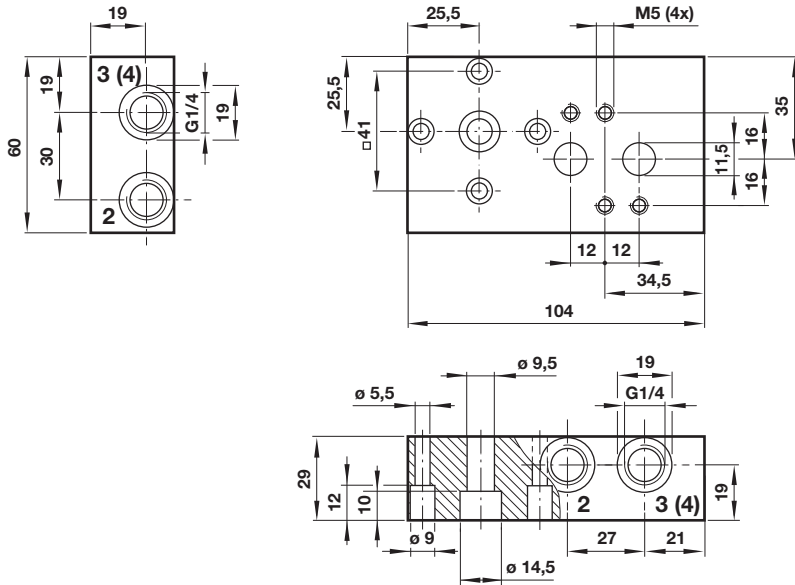

NAMUR slot

Type: 0612791

Dimensions in mm
Projection/First angle

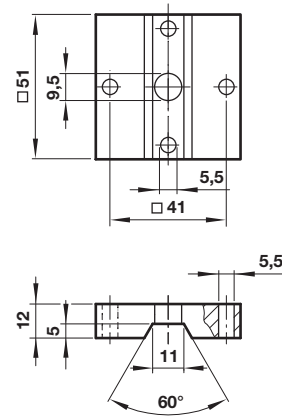

Yoke

Type: 0540593

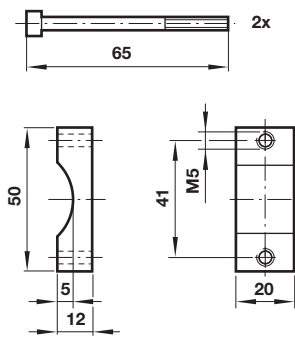

Throttle control plate

Model: 4040239

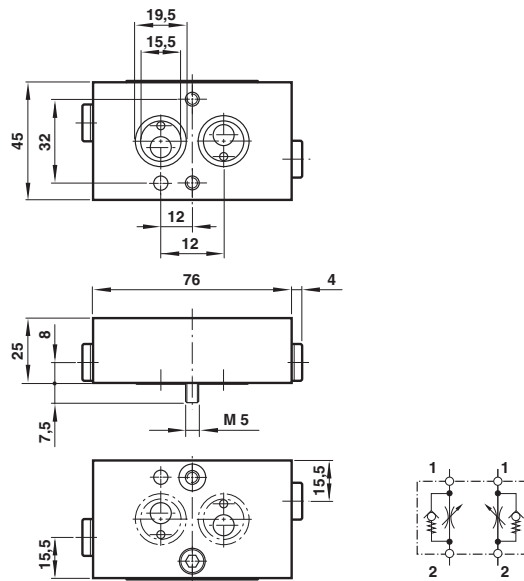

Distance plate

When using solenoids
42xx, 46xx or 37xx.

Model: 0540109

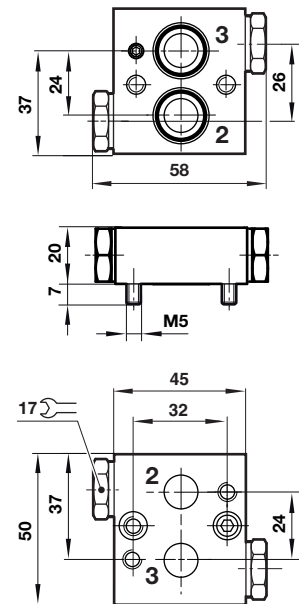

1 G1/4 ports for pressure switches

Silencer
Model: M/S2, C/S2

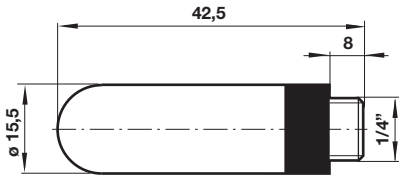

Exhaust guard
Model: 0613422

Dimensions in mm
Projection/First angle

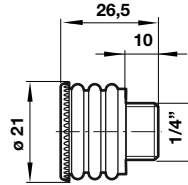

Cable gland

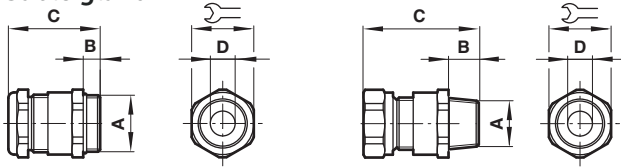

0588925
only

A	B	C	ø D		Model
M20 x 1,5	10	40	7,0 ... 12,0	24	0589735
M20 x 1,5	10	43	10,0 ... 14,0	27	0589736
M20 x 1,5	10	40	6,0 ... 12,0	24	0589737
M20 x 1,5	10	39,5	5,0 ... 10,0	24	0589739
M20 x 1,5	9	36	5,0 ... 8,0	22	0588819
M20 x 1,5	12	37	9,0 ... 14,0	30	0588851
1/2 NPT	15	58	7,5 ... 11,9	24	0588925
M20 x 1,5	6,5	27,5	9,0 ... 13,0	22	0589385
M20 x 1,5	16	40	7,0 ... 12,0	24	0589395
M20 x 1,5	16	41	10,0 ... 14,0	24	0589387

Warning

These products are intended for use in industrial compressed air systems only. Do not use these products where pressures and temperatures can exceed those listed under »**Technical features/data**«.

Before using these products with fluids other than those specified, for non-industrial applications, life-support systems or other applications not within published specifications, consult Norgren.

Through misuse, age, or malfunction, components used in fluid power systems can fail in various modes.

The system designer is warned to consider the failure modes of all component parts used in fluid power systems and to provide adequate safeguards to prevent personal injury or damage to equipment in the event of such failure.

System designers must provide a warning to end users in the system instructional manual if protection against a failure mode cannot be adequately provided.

System designers and end users are cautioned to review specific warnings found in instruction sheets packed and shipped with these products.