

- Neat, attractive styling with low overall height
- Short operating movement with light force minimise operator fatigue
- Large pedal area
- Suitable for 3/2 function



**4/2 Spool Valves  
Manually Operated  
G<sup>1</sup>/<sub>4</sub>**

### Technical Data

Medium:

Compressed air, filtered, lubricated and non-lubricated

Operation:

Spool valve, bleed operated

Mounting:

Through-holes in valve body, threaded. Optional mounting plate.

Port Size:

G<sup>1</sup>/<sub>4</sub>

Operating Pressure:

2 - 10 bar

Flow (to CETOP RP50P):

'C' - Conductance dm<sup>3</sup>/s/bar 1,80

'b' - Critical pressure ratio 0,10

Cv 0,373

Operating Temperature:

-20°C\* to +80°C

\*Consult our Technical Service for use below +2°C

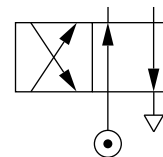

### Materials

Diecast zinc alloy valve body, diecast aluminium foot pedal, nitrile rubber seals.

### Ordering Information

To order, quote model number from table overleaf, e.g. M/649/99 for the Pedal Pilot Pressure Release Operated, Air Return model.

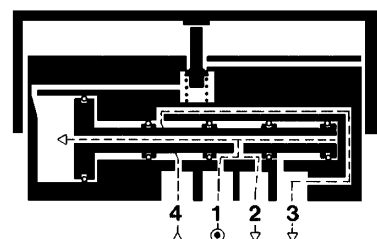



## General Information

Model	Operation	Return	Weight (kg)	Spares kit
M/649/99	Pedal	Air	0,70	QM/649/99/00
M/649/119	Pedal	Pedal	0,70	QM/649/99/00

## Warning

These products are intended for use in industrial compressed air systems only. Do not use these products where pressures and temperatures can exceed those listed under 'Technical Data'.

Before using these products with fluids other than those specified, for non-industrial applications, life-support systems, or other applications not within published specifications, consult NORGREN MARTONAIR.

Through misuse, age, or malfunction, components used in fluid power systems can fail in various modes. The system designer is warned to consider the failure modes of all component parts used in fluid power systems and to provide adequate safeguards to prevent personal injury or damage to equipment in the event of such failure.

**System designers must provide a warning to end users in the system instructional manual if protection against a failure mode cannot be adequately provided.**

System designers and end users are cautioned to review specific warnings found in instruction sheets packed and shipped with these products.

## Pedal Pilot Pressure Release Operated, Air Return

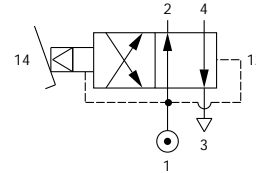
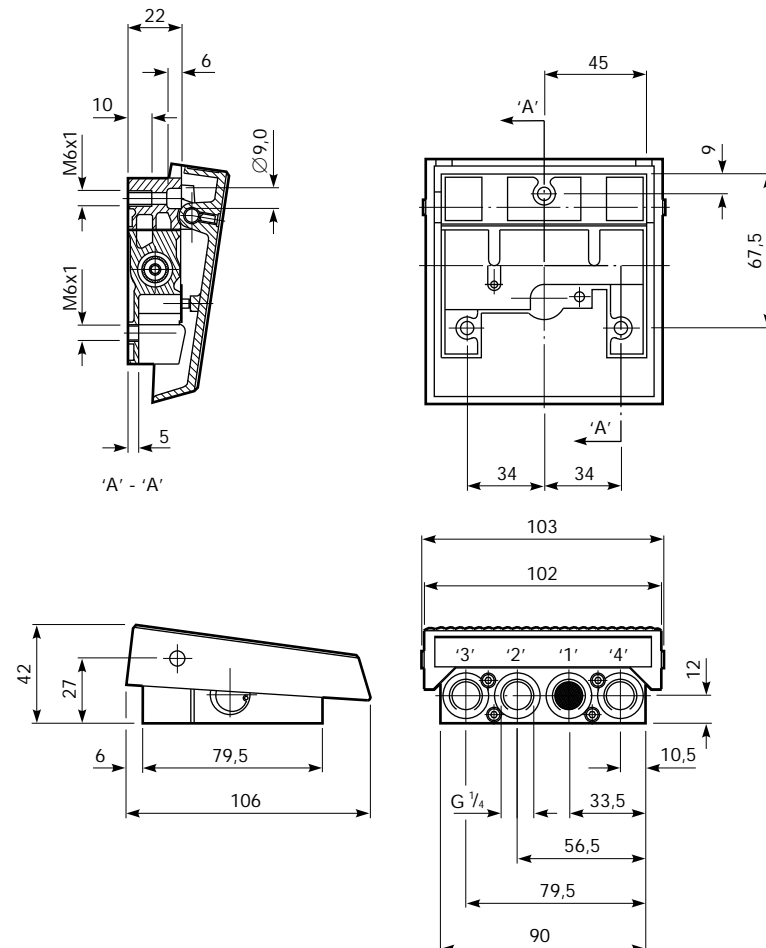

Model Number: **M/649/99**

Type: 4/2

Operating Force: 13,5 N @ 2 bar  
22 N @ 10 bar

To avoid accidental operation the valve should be installed in a protected position.

For use as a 3/2 valve, plug the unwanted outlet port.

## Fixing Instructions

Remove setscrew, pedal spindle and pedal, insert cap head fixing screws in fixing holes and secure valve to fixing surface. Replace pedal, pedal spindle and setscrew. Clearance provided through fixing holes for M5 screws. Mounting plate QM/1149 is available as an optional alternative, see Accessories.



**Pedal Pilot Pressure Release Set, Pedal Pilot Pressure Release Re-set**

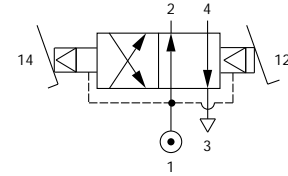
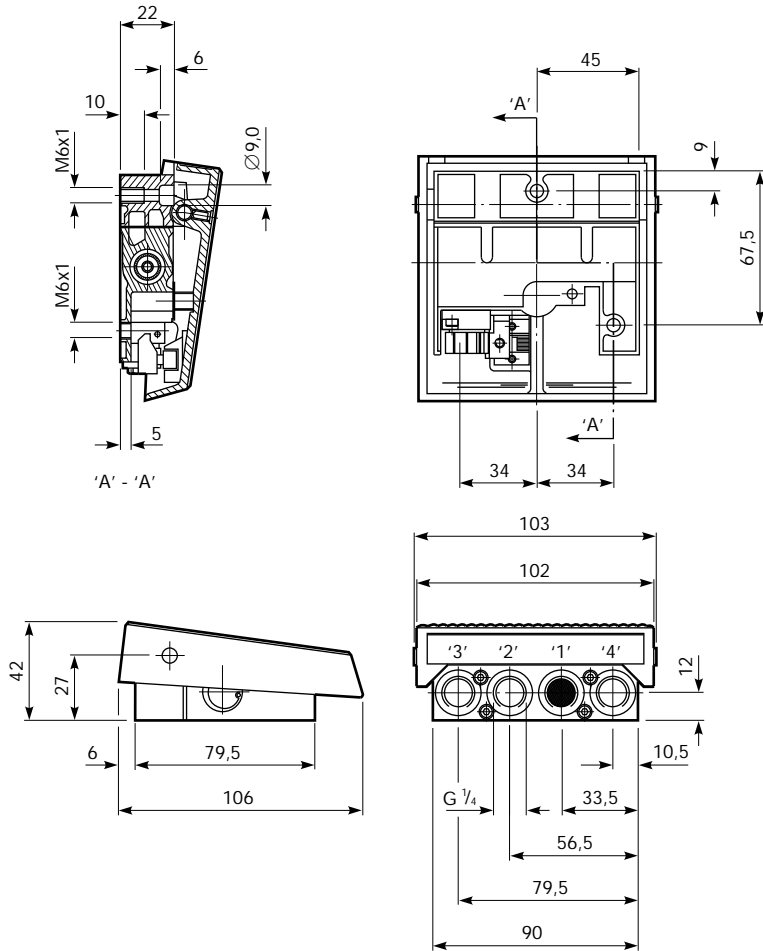

Model Number: **M/649/119**

Type: 4/2

Operating Force: 35,5 N @ 10 bar

To avoid accidental operation the valve should be installed in a protected position.

For use as a 3/2 valve, plug the unwanted outlet port.

**Fixing Instructions**

Remove setscrew, pedal spindle and pedal, insert cap head fixing screws in fixing holes and secure valve to fixing surface. Replace pedal, pedal spindle and setscrew ensuring that the pawl is correctly engaged with the ratchet and the return spring is correctly located. Clearance provided through fixing holes for M5 screws. Mounting plate QM/1149 is available as an optional alternative, see Accessories.

**Accessories**

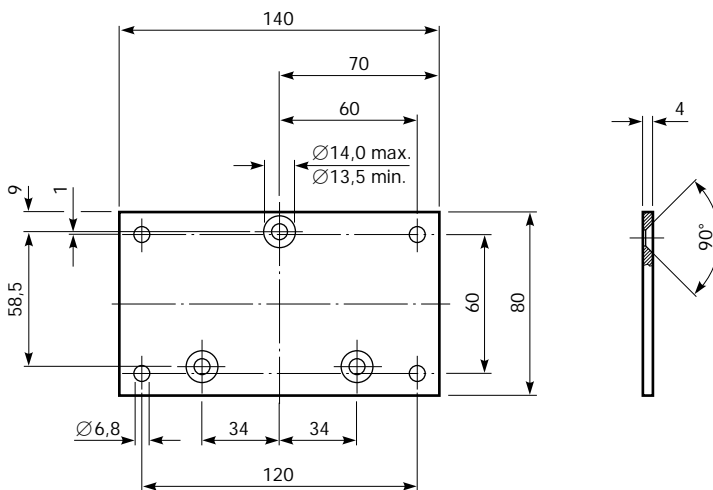

Mounting Plate for use when the valve cannot be mounted in the normal manner, reference QM/1149. Includes three M6 x 1 x 10 long bolts.