

EXCELON® 72
Filter-Lubricator Combination Units
1/4" and 3/8" Port Sizes

- **True modularity with Norgren Quikclamp™ connections**
- **Quick release bayonet bowl**
- **Flow sensor design provides a nearly constant oil/air ratio over a wide range of air flows**
- **Highly visible, prismatic liquid level indicator lens**
- **All around (360°) visibility of the sight-feed dome simplifies installation and adjustment**

Use Micro-Fog models in applications containing one or more points of lubrication.

Use Oil-Fog models to lubricate a single tool, cylinder, or other air driven device.



Technical Data

Fluid: Compressed air

Maximum pressure:

Transparent bowl: 10 bar (150 psig)

Metal bowl:

Manual or semi automatic drain: 17 bar (250 psig)

Automatic drain: 10 bar (150 psig)

Operating temperature*:

Transparent bowl: -20° to +50°C (0° to +125°F)

Metal bowl: -20° to +65°C (0° to +150°F)

* Air supply must be dry enough to avoid ice formation at temperatures below +2°C (+35°F).

Particle removal: 5 µm, 25 µm, or 40 µm filter element

Typical flow with 6,3 bar (90 psig) inlet pressure and 0,5 bar (7 psig)

pressure drop: ??? dm³/s (??? scfm) **Waiting on lab test**

Manual drain connection: 1/8"

Semi automatic drain connection: Push on 8 mm (5/16") ID tube

Semi automatic drain operating conditions (pressure operated):

Bowl pressure required to close drain: Greater than 0,1 bar (1.5 psig)

Bowl pressure required to open drain: Less than 0,1 bar (1.5 psig)

Minimum air flow required to close drain: 0,5 dm³/s (1 scfm)

Manual operation: Lift stem to drain bowl

Automatic drain connection: 1/8"

Automatic drain operating conditions (float operated):

Bowl pressure required to close drain: Greater than 0,3 bar (5 psig)

Bowl pressure required to open drain: Less than 0,2 bar (3 psig)

Minimum air flow required to close drain: 0,1 dm³/s (0.2 scfm)

Manual operation: Depress pin inside drain outlet to drain bowl

Nominal bowl size:

Short bowl: 56 ml (1.9 fluid ounce)

Long bowl: 65 ml (2.2 fluid ounce)

Recommended lubricants: See page N/AL.8.900.935

Materials:

Body: Zinc

Bowl:

Transparent: Polycarbonate

Transparent with guard: Polycarbonate,

Zinc guard

Metal: Zinc

Metal bowl liquid level indicator lens:

Transparent nylon

Element: Sintered polypropylene

Sight-Feed dome: Transparent nylon

Elastomers: Neoprene, nitrile, and Geolast®

Ordering Information

See *Ordering Information* on the following pages.

ISO Symbols

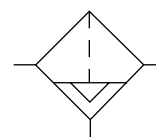

Filter with Automatic Drain

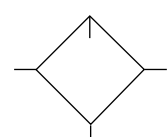

Lubricator with Drain



Ordering information. Models listed in order table have ISO G parallel threads. Filter (F) has semi automatic drain, short transparent bowl without guard, and a 40 µm element. Lubricator (L) is a Micro-Fog model with 1/4 turn manual drain and short transparent bowl without guard.

Combination Unit Type	Port Size	Model	Flow* dm ³ /s (scfm)	Weight kg (lb)
Filter-Lubricator (F-L)	G1/4	C72C-2GN-ST3-NNN-QTN	?? (?? Waiting on test)	1,04 (2.3)
	G3/8	C72C-3GN-ST3-NNN-QTN	?? (?? Waiting on test)	1,04 (2.3)

* Typical flow with a 40 µm filter element at 6,3 bar (90 psig) inlet pressure and 0,5 bar (7 psig) pressure drop.

Alternative Models



Shutoff/Lockout Valve, Quikmount	Substitute
Standard Combination (No Shutoff/Lockout Valve, no Quikmount)	C
With Shutoff/Lockout valve on inlet	D
With Quikmount pipe adapters on inlet and outlet	E
With Shutoff/Lockout Valve on inlet and Quikmount pipe adapter on outlet	G

Combination Unit Type	Substitute
Micro-Fog F-L	C
Oil-Fog F-L	D

Port Size	Substitute
1/4"	2
3/8"	3

Threads	Substitute
PTF	A
ISO Rc taper	B
ISO G parallel	G

Regulator Option	Substitute
Non Applicable	N

Filter Drain	Substitute
Automatic †	A
Manual, 1/4 turn	Q
Semi automatic	S

Filter Bowl	Substitute
Short metal with liquid level indicator	D
Short transparent without guard	T
Long transparent without guard	L
Long transparent with guard	W

Accessories	Substitute
Quikclamp wall brackets	B
No accessories	N

Lubricator Reservoir	Substitute
Short metal with liquid level indicator	D
Short transparent without guard	T
Long transparent without guard	L
Long transparent with guard	W

Lubricator Drain	Substitute
Closed bottom	E
Manual, 1/4 turn	Q

Regulator Option	Substitute
Non Applicable	N

Regulator Option	Substitute
Non Applicable	N

Regulator Option	Substitute
Non Applicable	N

Filter Element	Substitute
5 µm	1
25 µm	2
40 µm	3

Accessories. See page N/AL.8.160.700.



Dimensions mm (inches). See pages N/AL.8.160.100, N/AL.8.160.400, N/AL.8.180.600, and N/AL.8.180.700 for dimensions of individual products and the Quikclamp wall bracket.

**Standard Micro-Fog Type C72C-
Standard Oil-Fog Type C72D-**

Shown with optional gauge and Quikclamp wall bracket.

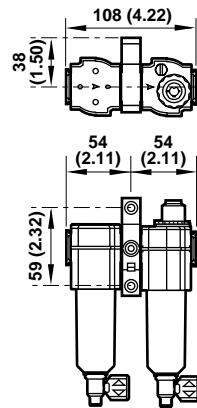

**Alternative Micro-Fog Type D72C-
Alternative Oil-Fog Type D72D-**
Includes Shutoff/Lockout valve.

Shown with optional gauge and Quikclamp wall brackets.

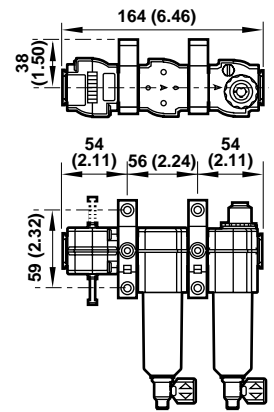

**Alternative Micro-Fog Type E72C-
Alternative Oil-Fog Type E72D-**
Includes Quikmount pipe adapters.

Shown with optional gauge and Quikclamp wall brackets.

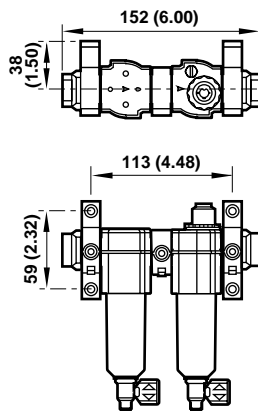

**Alternative Micro-Fog Type G72C-
Alternative Oil-Fog Type G72D-**
Includes Shutoff/Lockout valve and Quikmount pipe adapter.

Shown with optional gauge and Quikclamp wall brackets.

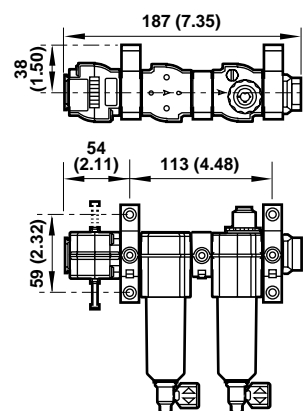

Typical Performance Characteristics

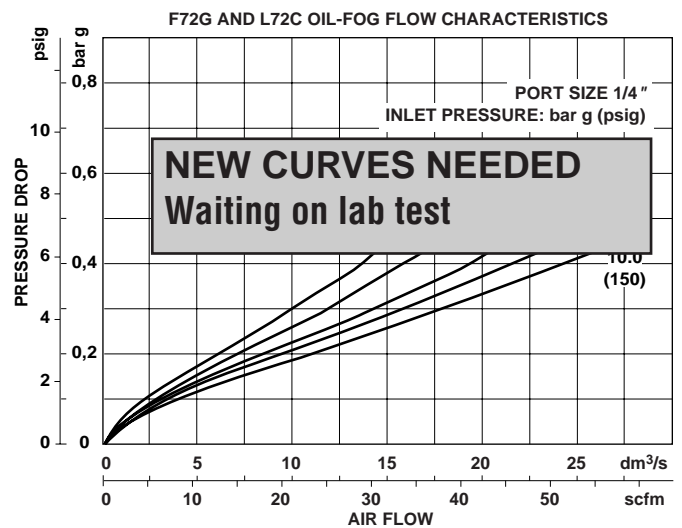
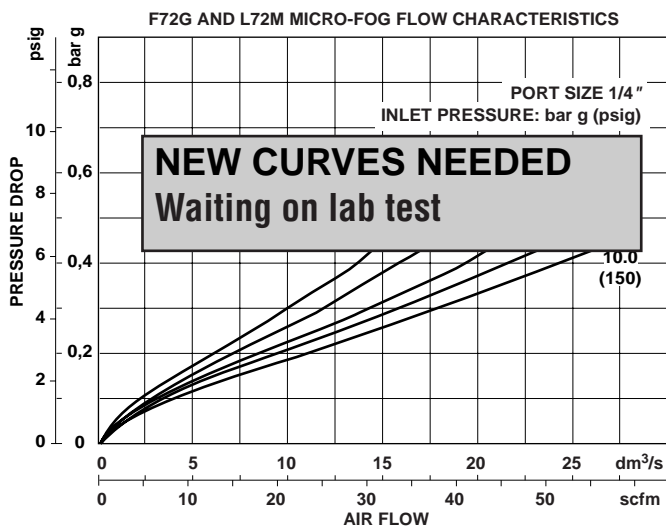



Warning

These products are intended for use in industrial compressed air systems only. Do not use these products where *pressures* and *temperatures* can exceed those listed under **Technical Data**.

Before using these products with fluids other than those specified, for non-industrial applications, life-support systems, or other applications not within published specifications, consult Norgren.

Through misuse, age, or malfunction, components used in fluid power systems can fail in various modes. The system designer is warned to consider the failure modes of all component parts used in fluid power systems and to provide adequate safeguards to prevent personal injury or damage to equipment in the event of such failure.

System designers must provide a warning to end users in the system instructional manual if protection against a failure mode cannot be adequately provided.

System designers and end users are cautioned to review specific warnings found in instruction sheets packed and shipped with these products.