

# R18

## General purpose pressure regulators

- Port size: 1 1/2" & 2" (ISO G, PTF)
- Can be installed at any point in the compressed air system without regard to accessibility – pilot regulator can be installed in the most convenient location
- Accurate pressure regulation over a wide range of flows
- Can be used with conventional pilot regulator



### Technical features

<b>Medium:</b> Compressed air only	<b>Typical flow:</b> See below	<b>Relieving:</b> Standard	<b>Materials:</b> Body & bonnet: Aluminum alloy Bottom plug: Acetal Valve: Aluminum and PA Elastomers: NBR
<b>Operation pressure:</b> 31 bar (450 psi) maximum	<b>Main port size:</b> 1 1/2" & 2"	<b>Ambient/Media temperature:</b> -20°C ... 80°C (0°F ... +175°F) Version with gauge: -20°C ... +65°C (-4°F ... +149°F) Air supply must be dry enough to avoid ice formation at temperatures below +2°C (+35°F).	
<b>Pressure range:</b> Without Pilot regulator *2) 0,16 ... 17 bar (2.3 ... 246 psi) With pilot regulator R40: 0,3 ... 8,5 bar (4.3 ... 123 psi) *2) Further ranges see option selector	<b>Relieving port:</b> 3/4 PTF with PTF main ports G3/4 with ISO G main ports		
	<b>Gauge port:</b> 1/4 PTF with PTF main ports Rc1/4 with ISO G main ports		

### Technical data, standard models

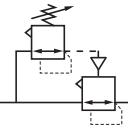
Symbol	Port size	Flow *1) (dm <sup>3</sup> /s)	Pilot regulator	Outlet pressure range (bar)	Weight (kg)	Model
	G1 1/2	944	–	0,16 ... 17 *2)	3,09	R18-B00-RNXG
	G2	944	–	0,16 ... 17 *2)	2,99	R18-C00-RNXG
	G1 1/2	944	R40 included	0,3 ... 8,5	3,85	R18-B05-RNLG
	G2	944	R40 included	0,3 ... 8,5	3,75	R18-C05-RNLG
	G1 1/2	944	R41 included	7 ... 17	3,85	R18-B06-RNSG *3)
	G2	944	R41 included	7 ... 17	3,75	R18-C06-RNSG *3)

\*1) Typical flow with 7,0 bar (101 psi) inlet pressure, 6,3 bar (91 psi) set pressure and a 1 bar (14,5 psi) droop from set.

\*2) Operating pressure range is determined by the spring range of the piloting regulator. Norgren recommends the use of its R40/R41

\*3) Attention: Not all applications are suitable for the use of closed loop ( feedback) regulator circuit. To discuss your application needs please contact our technical department

### Option selector

**R18-★0★-★N★★**

Port size	Substitute
1 1/2"	B
2"	C
Pilot regulator	Substitute
Without (standard)	0
With R40 conventional	5
With R41 feedback *1)	6

\*1) Requires relieving diaphragm and 17 bar (250 psig) spring (R in 7th position and S in 9th position) e.g. R18-B06-RNSG. The 06 option cannot be used at an outlet pressure below 7 bar (100 psig). For feedback control at pressures below 7 bar (100 psig) use an 11-204-004 with a pilot operated R18.

Thread form	Substitute
PTF	A
ISO G	G
Outlet pressure range *2)	Substitute
Without (standard)	X
0,3 ... 3,5 bar (with R40)	E
0,3 ... 8,5 bar (with R40)	L
0,7 ... 17 bar (with R40)	S
7 ... 17 bar (with R41) *1)	S
Diaphragm	Substitute
Relieving	R
Non relieving	N

\*2) Outlet pressures can be adjusted to pressures in excess of, and less than, those specified. Do not use these units to control pressures outside of the specified ranges.

### Flow characteristics

Port size: 2",  
Inlet pressure: 6,9 bar, pilot spring range 0,3 ... 8,5 bar

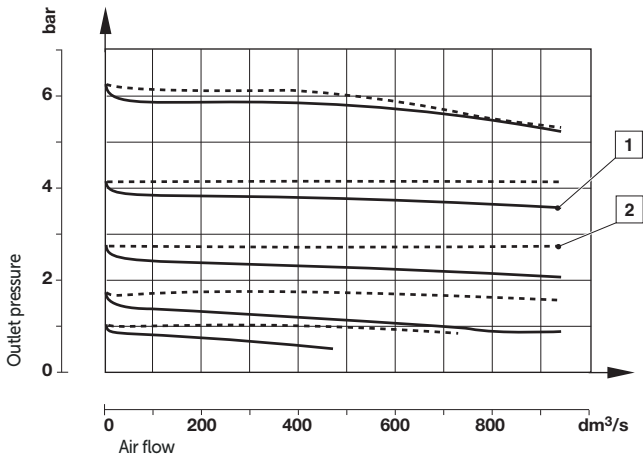

- 1 R18 with R40 conventional pilot
- 2 R18 with R41 feedback pilot

### Relief characteristics

Port size: 2",  
Inlet pressure: 10 bar

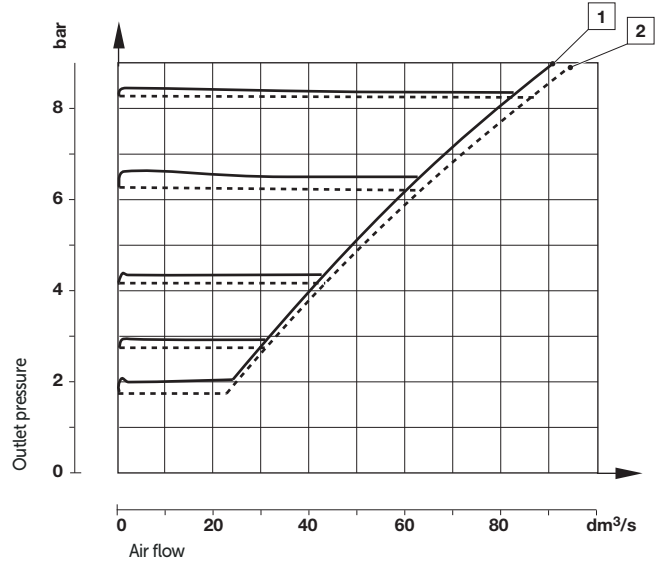

### Accessories

Silencer

Page 4

R3/4	MB006B
3/4 NPT	MB006A

Concentric reducing adaptors for gauge ports

R1/4-G1/8: 150232818

### Service kits

Service kit

R18 without Pilot regulator: R18-100R  
R18 with Pilot regulator R40: R18-100R & 5945-41  
R18-100R & 5945-41 (R18 & R40)

### Gauge

Center back connection, white face

(for full technical specification see datasheet 8.900.900)

Pressure range					
bar *1)	Mpa	psi	Ø	Thread size	Model
0 ... 1.6	0 ... 0,16	0 ... 23	50 mm	R1/8	18-015-010
0 ... 4	0 ... 0,4	0 ... 58	50 mm	R1/8	18-015-011
0 ... 6	0 ... 0,6	0 ... 87	50 mm	R1/8	18-015-012
0 ... 10	0 ... 1	0 ... 145	50 mm	R1/8	18-015-013
0 ... 25	0 ... 2,5	0 ... 362	50 mm	R1/8	18-015-014

\*1) primary scale

### Gauge for North America

Center back connection, black face for North America

(for full technical specification see datasheet 8.900.900)

Pressure range					
psig *1)	bar	Mpa	Ø	Thread size	Model
0 ... 30	0 ... 2	0 ... 0,2	2" (50 mm)	1/4 NPT	18-015-207
0 ... 60	0 ... 4	0 ... 0,4	2" (50 mm)	1/4 NPT	18-015-208
0 ... 160	0 ... 11	0 ... 1,1	2" (50 mm)	1/4 NPT	18-015-209
0 ... 300	0 ... 20	0 ... 2,1	2" (50 mm)	1/4 NPT	18-015-210

\*1) primary scale

## Dimensions

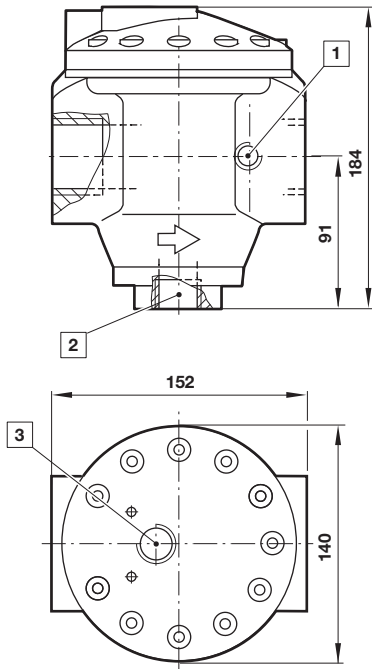

Dimensions in mm  
Projection/First angle



## Silencer

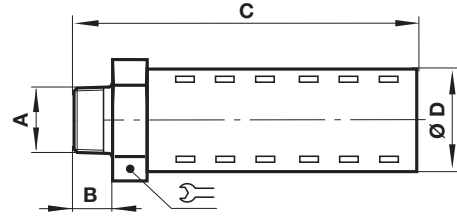

A	B	C	D		Model
R3/4	20	134	51	51	MB006B
3/4 NPT	20	134	51	51	MB006A

## With pilot regulator R40

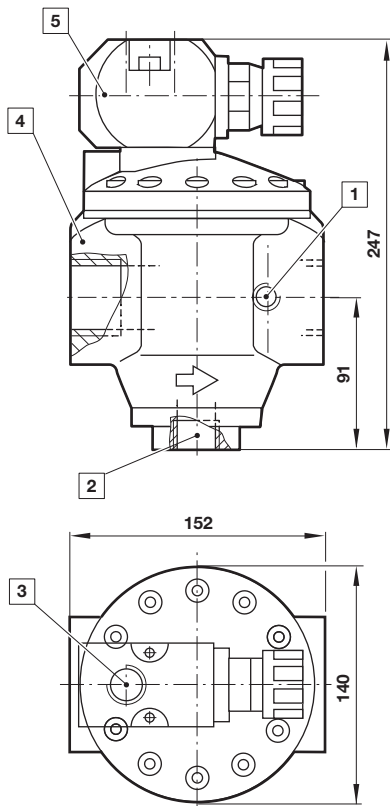

## With feedback pilot regulator R41

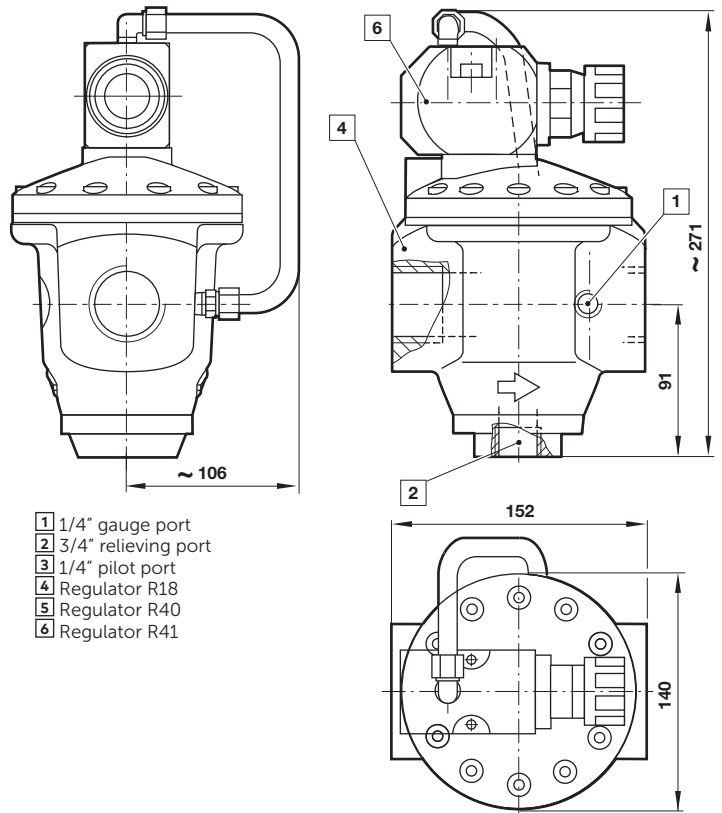

- 1 1/4" gauge port
- 2 3/4" relieving port
- 3 1/4" pilot port
- 4 Regulator R18
- 5 Regulator R40
- 6 Regulator R41

## Warning

These products are intended for use in industrial compressed air systems only. Do not use these products where pressures and temperatures can exceed those listed under »**Technical features/data**«.

Before using these products with fluids other than those specified, for non-industrial applications, life-support systems or other applications not within published specifications, consult Norgren.

Through misuse, age, or malfunction, components used in fluid power systems can fail in various modes.

The system designer is warned to consider the failure modes of all component parts used in fluid power systems and to provide adequate safeguards to prevent personal injury or damage to equipment in the event of such failure.

System designers must provide a warning to end users in the system instructional manual if protection against a failure mode cannot be adequately provided.

System designers and end users are cautioned to review specific warnings found in instruction sheets packed and shipped with these products.