

Industrial Automation

IMI Norgren
IMI Bahr

Electric Motion
Product Overview

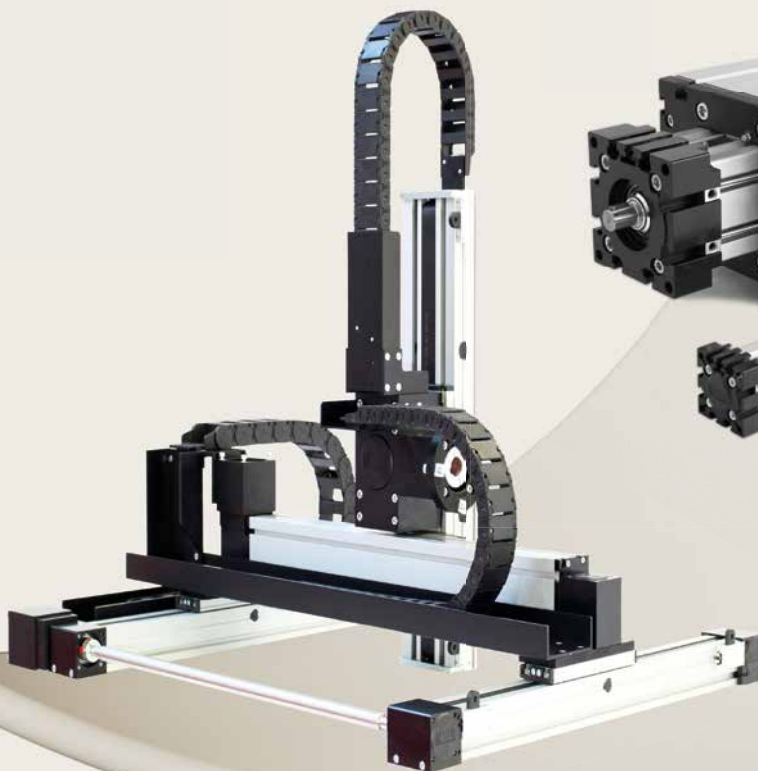

Breakthrough
engineering for
a better world

Breakthrough engineering for a better world

We create solutions for our customers which enable smarter, safer, more productive and sustainable factories, production lines and warehouse operations. Our pneumatic and electric motion systems help machine builders and end users around the world automate and optimise manufacturing and warehousing processes.

We have partnered with customers in industrial automation for over a century, applying our experience and innovation to create lasting value for their businesses. Our solutions support critical industries such as automotive, food and beverage, pharmaceuticals and even the space industry. We support the automation of precision manufacturing, product assembly, testing and packaging.

We use the latest digital technologies in our automation products and constantly innovate in close partnership with our customers. By applying our deep expertise, we can solve their toughest automation challenges, today and tomorrow. Through increased productivity, efficiency and safety, our customers can serve their own customers better, creating sustainable competitive advantage and delivering growth.

Our world-class product portfolio includes IMI Norgren, IMI Bimba, IMI Bahr and IMI Buschjost.

Breakthrough engineering you can count on.

Benefits of Electric Motion

Designed to meet our customers' requirements, we now offer an expanded range of high-performance Electric Motion solutions suited to a variety of industrial applications across Material Handling, Pharmaceuticals, Food & Beverage, Battery Production and Factory Automation sectors.

Our Electric Motion solutions include Rod style electric cylinders, rodless linear axes and custom built cartesian and gantry systems for multi-axis applications. Our wide range of drive, guide and profile options (with over 10,000 possible configurations) allow us to individually design solutions that offer customers complete flexibility.

The requirements for modern industrial automation applications are becoming increasingly complex, and whether its precise control, accurate positioning, repeatability or wear-free operation - our Electric Motion products are built on over 30 years of extensive application experience, to deliver Breakthrough Engineering you can count on.

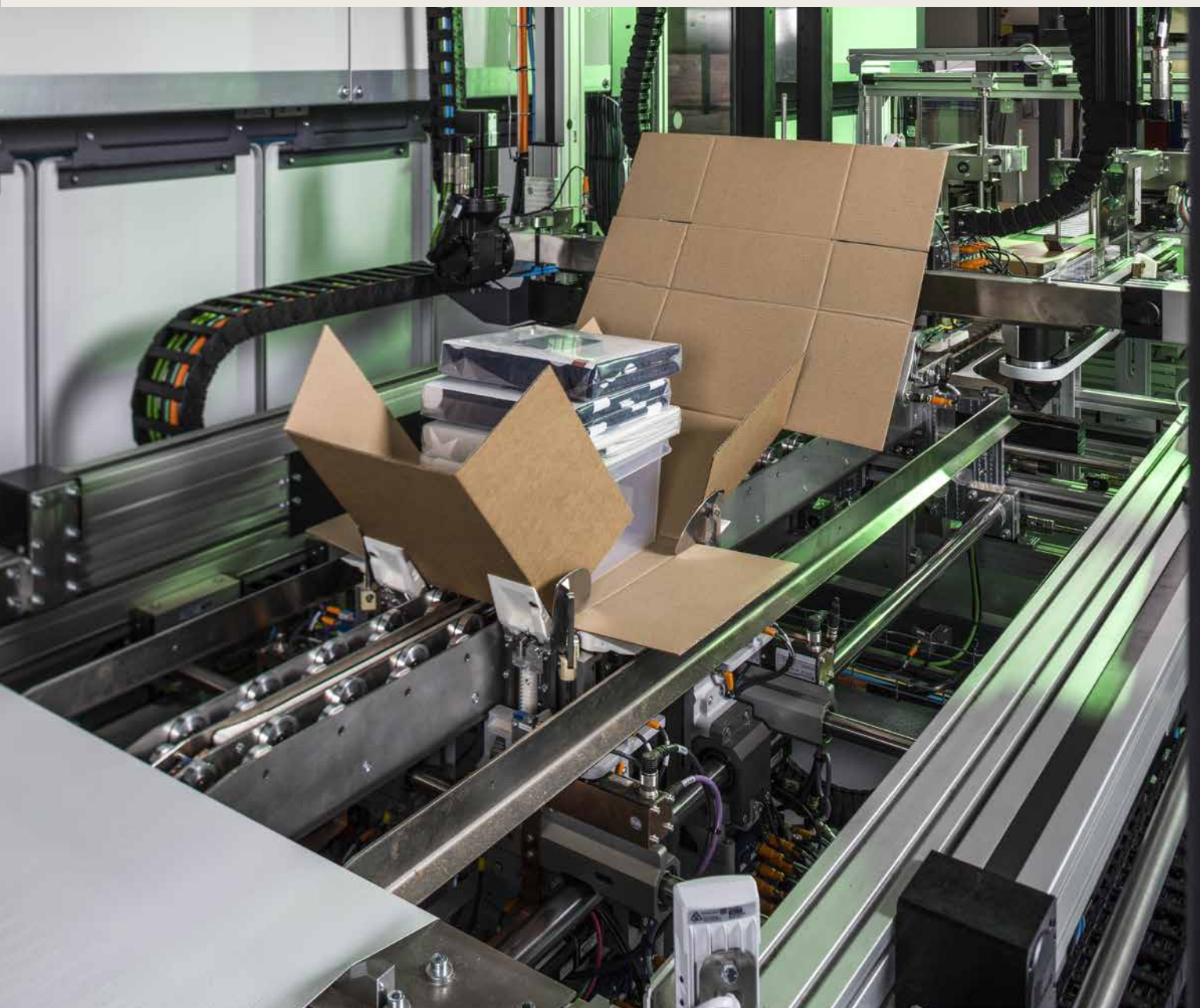

Electric Motion

Our Electric Motion solutions are designed to meet the most demanding performance requirements. We offer an unparalleled engineering service including Application Engineering support, complete 3D CAD models & drawings, and life & cycle time calculations.

To ensure we meet your exact specifications and to guide you in choosing the right solution for your application, our experienced technical team provide comprehensive needs assessment, advice, and technical support from design through to delivery.

- Technical consultation and needs assessment
- Complete offer within 48-hours with 3D model, drawings, life and cycle time calculation
- Gearbox and motor dimensioning on request
- Structural analysis for critical applications on request
- Guidance on specialist applications such as ATEX/Ex-Proof, Cleanroom etc.
- Design of project-specific special components and accessories such as energy chains and support frames
- Repair, maintenance and spare parts for any system



Fast response to queries



Application Engineering



After Sales Service and Support



●● We offer a one-stop shop for your Electric Motion needs ●●



- Customised Accessories
- Custom-built configurations and manufacturing
- Technical consultation
- CAD simulation and analysis
- Best-In-Class Service
- Calculations and FEA analysis

Fast Find Guide

Electric Cylinders



Linear Axis

E Series



D Series



Q Series



L Series



Multi Axis Systems / Accessories

ELZI Series



ELZU Series



Multi Axis Systems









Accessories



Options

Our extensive product portfolio includes more than 200 body profiles, drive and guide systems as well as comprehensive accessories enabling endless configuration options for single and multi-axis systems.

Complex multi-axis systems are indispensable in today's industrial world and are playing an increasingly important role in mechanical engineering. To ensure we meet our customers' exact specifications, our experienced technical team is on hand to provide comprehensive needs analysis, advice and technical support from design through to delivery.

	Guide options			Drive options				
	Sliding Guide	Roller Guide	Rail Guide	Spindle	Belt	Rack	LinearMotor	
Electric Cylinder  E/809000 Series	●	●	●	●	●	●	●	<ul style="list-style-type: none"> Based on ISO 15552 standard Suited for applications with high force & repeatable positioning requirements IP65 rated options for operation in wet and dusty environments
E Series 	●	●	●	●	●	●	●	<ul style="list-style-type: none"> Robust in harsh environments Long traverse path Suited for use in potentially explosive areas Easy maintenance Dynamic
Linear Axis D Series 	●	●	●	●	●	●	●	<ul style="list-style-type: none"> Twin integrated internal guides for heavy-duty applications Robust in harsh environments Suited for use in cleanroom environments
Q Series 	●	●	●	●	●	●	●	<ul style="list-style-type: none"> Suited for use in cleanroom environments Flexible mounting position Long traverse path Dynamic
L Series 	●	●	●	●	●	●	●	<ul style="list-style-type: none"> Compact lightweight design Flexible mounting position Long traverse path Dynamic Suited for use in cleanroom environments
Multi-Axis Systems ELZI Series 	●	●	●	●	●	●	●	<ul style="list-style-type: none"> Dynamic X/Z portal Compact, lightweight design Suited to pick and place applications requiring high acceleration
ELZU Series 	●	●	●	●	●	●	●	<ul style="list-style-type: none"> Surface portal with 2 Y-axis and a single X-axis Compact, lightweight design Suited for pick and place applications requiring high acceleration

	Guide options			Drive options			
	Sliding guide	Roller guide	Rail guide	Spindle	Tooth belt	Rack and pinion	Linear Motor
Dynamics (v, a)	● ● ● ● ●	● ● ● ● ●	● ● ● ● ●	● ● ● ● ●	● ● ● ● ●	● ● ● ● ●	● ● ● ● ●
Accuracy	● ● ● ● ●	● ● ● ● ●	● ● ● ● ●	● ● ● ● ●	● ● ● ● ●	● ● ● ● ●	● ● ● ● ●
Maintenance	● ● ● ● ●	● ● ● ● ●	● ● ● ● ●	● ● ● ● ●	● ● ● ● ●	● ● ● ● ●	● ● ● ● ●
Life time	● ● ● ● ●	● ● ● ● ●	● ● ● ● ●	● ● ● ● ●	● ● ● ● ●	● ● ● ● ●	● ● ● ● ●
Stroke	● ● ● ● ●	● ● ● ● ●	● ● ● ● ●	● ● ● ● ●	● ● ● ● ●	● ● ● ● ●	● ● ● ● ●
Axial force [F]				● ● ● ● ●	● ● ● ● ●	● ● ● ● ●	● ● ● ● ●

Fields of Application

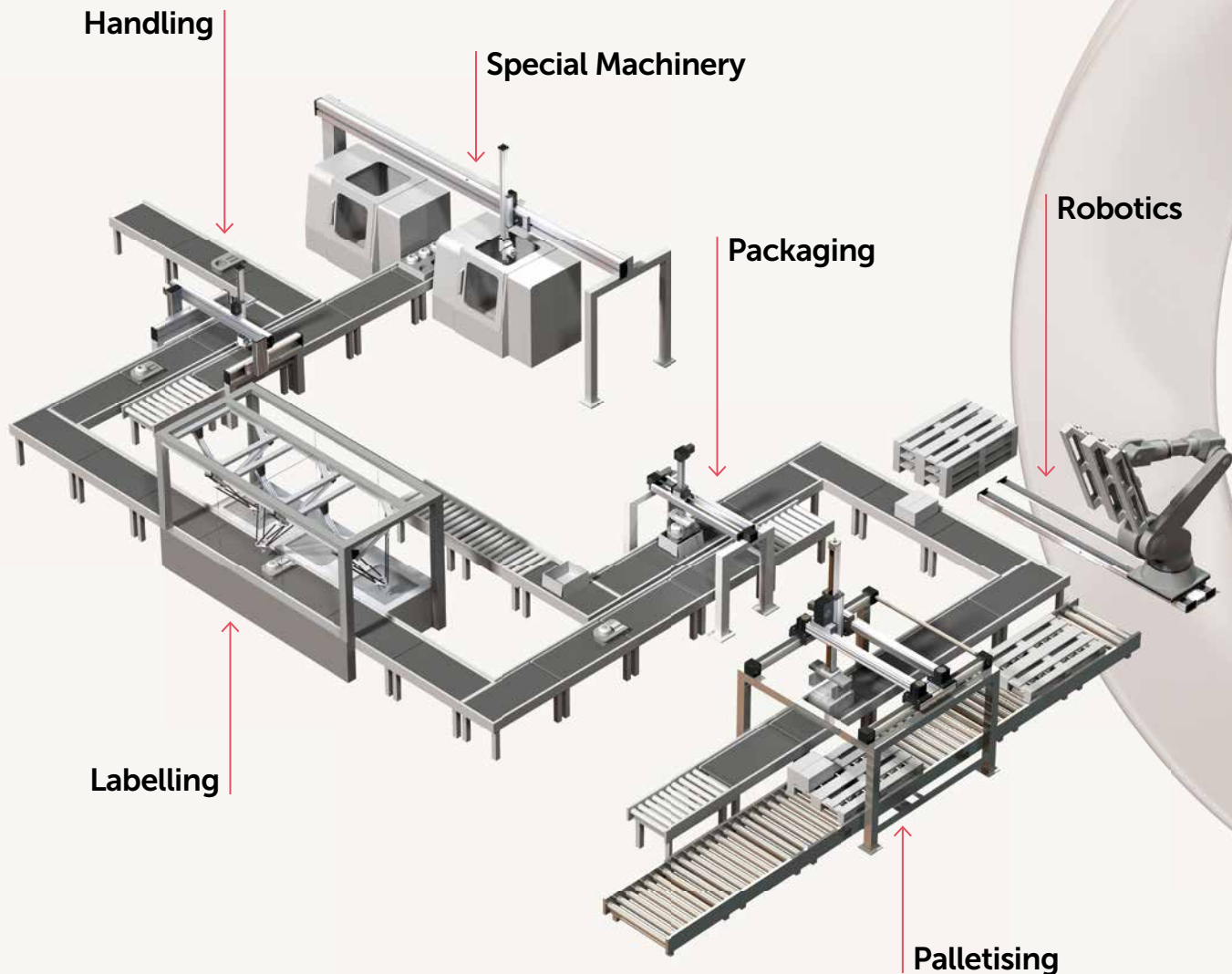

●● We develop customised solutions for all industrial requirements, from individual parts to serial production. ●●



Mechanical and Systems Engineering

- Coating, painting, welding, measuring and forming plants
- Glass, stone and wood working machinery



Lifting and Materials Handling Technology

- Bottling and dosing systems
- Electromechanical lifting systems
- Lift systems



Pharmacy Automation

- Automatic picking system



Automation and Electrical Engineering

- Assembly lines and storage systems
- Assembly and handling systems
- Measuring and inspection equipment



Food Industry

- Food and animal food production



Chemical and Pharmaceutical Industry

- Mixing, testing and dosing equipment
- Laboratory applications
- Clean-room conditions



Packaging Technology

- Labelling and packaging equipment
- Systems for cartoners, loaders, packers and deliverers



3D Printing

- Rapid prototyping
- Industrial 3D printing
- Sintered metal process
- Architectural projects

Rodless Actuators

Customised, high-quality linear units. The modular product portfolio allows endless combinations, high flexibility and maximum customisation for almost all automation applications.

Technical Specifications

- Wide range of more than 200 individual actuators
- Available in all drive and guide systems
- Structural profiles with high rigidity and pressing quality
- Compatible with all motor systems
- Certified for demanding environmental conditions
- Reliable & durable quality

Optional

- Individualisation outside of the portfolio through high-quality technical services and vertical integration with high product quality.

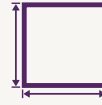

- Sizes 30, 40, 60, 80, 100, 120, 160, 200 mm



- Combination options for linear actuators with toothed belt, spindle, rack and pinion, linear motor drive; roller, sliding and rail guides

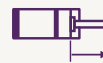

- 100 mm - 60.000 mm stroke



- Speed up to 12 m/s



- Load capacity from 1 kg to 1000 kg depending on the application



- Certified for clean room and ATEX

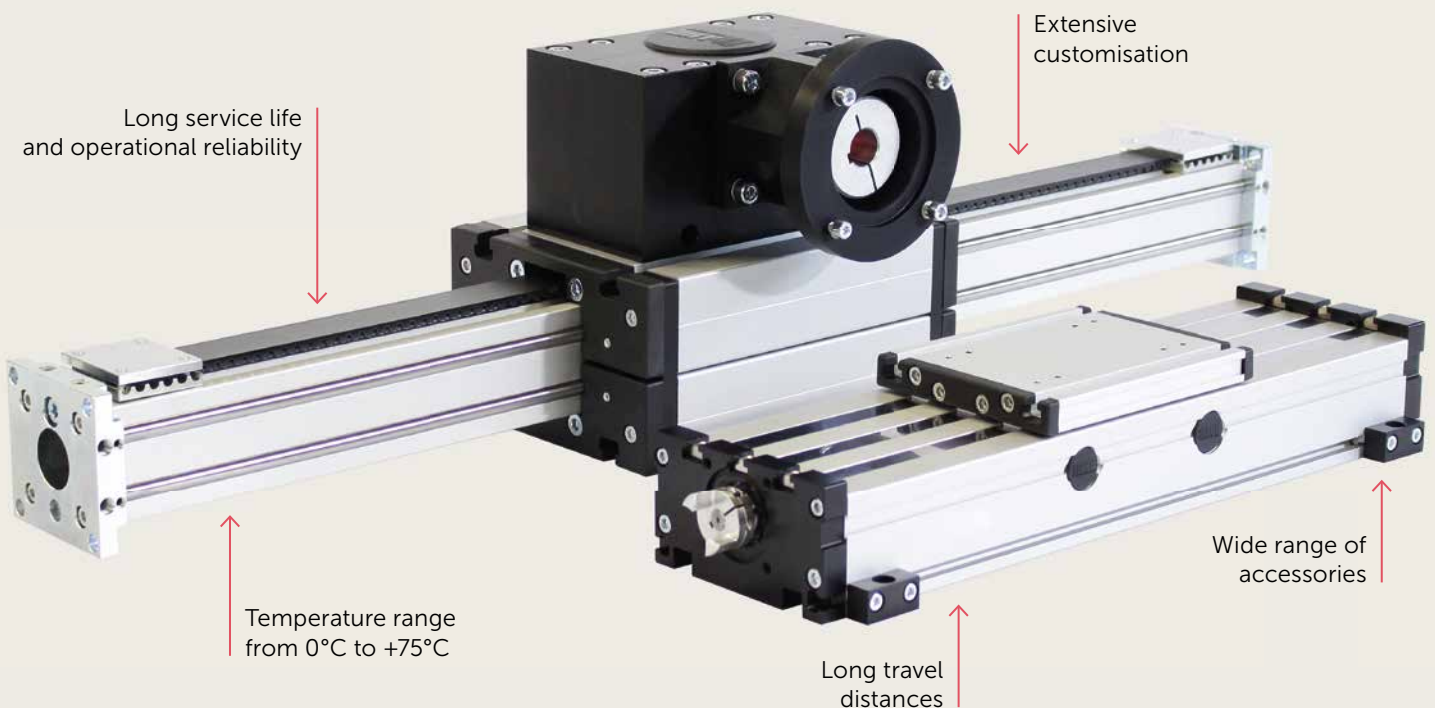

Rodstyle Actuators

The electric rod-style cylinder is based on ISO 15552 dimensions and is available in six different sizes, with and without a motor.

Technical Specifications

- Rod-style cylinders with ball screw drive
- 6 sizes
- Axial and parallel motor adaptation
- Robust design
- Based on ISO 15552
- Maintenance free
- Protection class IP65 with motor
- Reliable & durable quality

Optional

- Piston rod extension
- Internally threaded piston rod
- Piston rod bellows

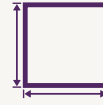

- 32, 40, 50, 63, 80, 100 mm



- Operating temperature
Cylinder: 0°C to +80°C



- Max. 1.6 m/s



- Up to 30.4 kN



- 100 mm - 1500 mm stroke



- Protection Class IP40 or IP65

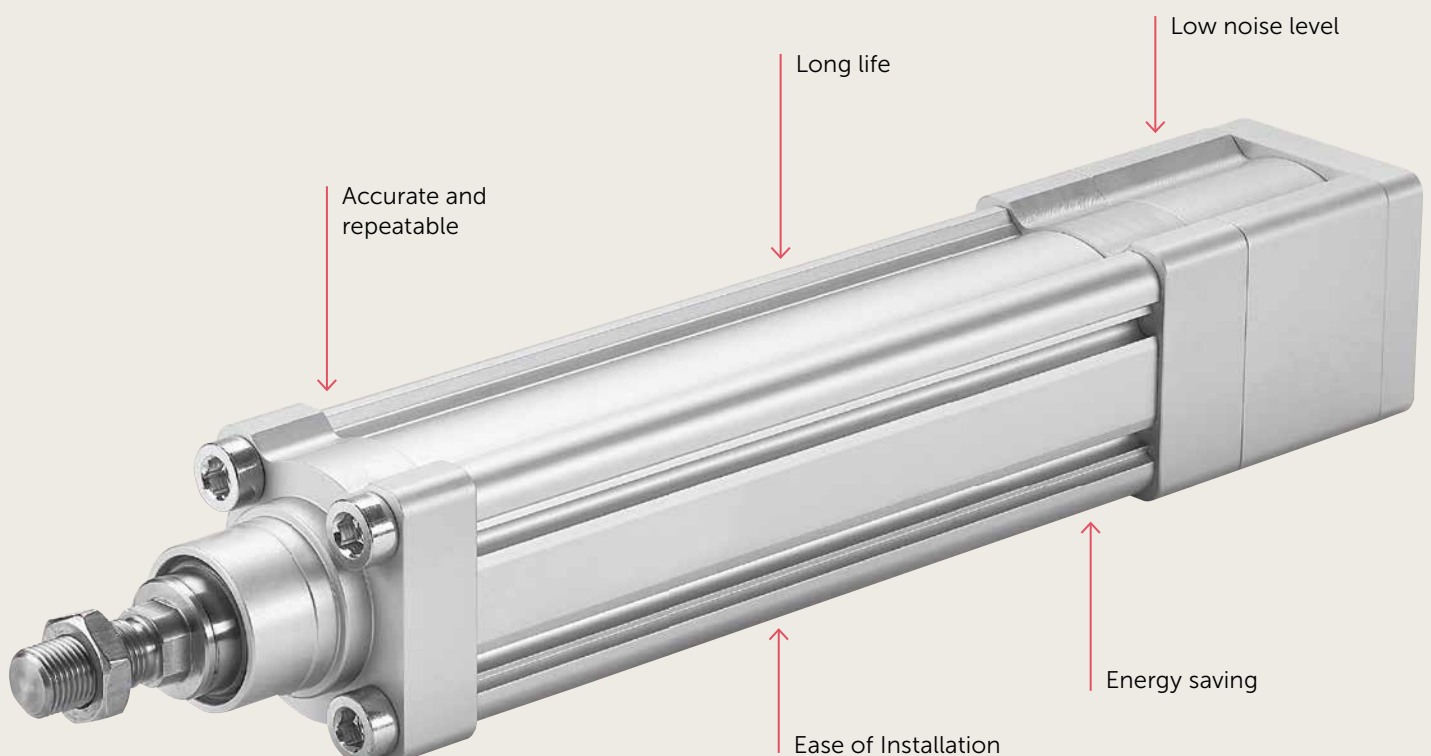

Linear Axis - E Series

ELZ range

For Standard Industrial Applications

Tooth belt driven Linear Axis range with a square, Aluminium profile and integrated hardened Steel guide rods.

- The carriage runs on internal linear ball bearings that can be adjusted free of play
- The pulleys have maintenance-free ball bearings
- Belt tension is adjusted via simple screw adjustment device in carriage
- Multiple units can be assembled in series to achieve extended strokes
- Carriage can be customised to include extensions and accessories mounted within the profile
- ATEX rated versions available



Tooth Belt Drive



Double Roller - Single Guided



- 30 – 40 – 60 – 80 – 100 – 125 mm



- Up to 5750 N



- Up to 6 m (standard)
- Up to 20 m (with axes joined in series)



- $\pm 0,1$ mm



- 10 m/s
- ATEX: 1 m/s



- Low maintenance

ELSZ range

For Standard Industrial Applications

Toothbelt driven Linear Axis range with a square, Aluminium profile and hardened Steel guide rods.

- Omega belt system provides flexibility with mounting, making this range ideally suited for vertical installations.
- The carriage runs on internal linear ball bearings that can be adjusted free of play
- The pulleys have maintenance-free ball bearings
- Belt tension is adjusted via simple screw adjustment device in carriage
- Alternative versions available with widened belt for higher load capacity



Omega Tooth Belt Drive

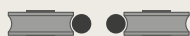

Double Roller - Single Guided



- 30 – 40 – 60 – 80 – 100 – 125 mm



- Up to 5750 N



- Up to 6 m (standard)
- Up to 20 m and longer (with axes joined in series)



- $\pm 0,1$ mm



- 10 m/s



- Low maintenance

Linear Axis - E Series

ELT / ELK range

For Standard Industrial Applications

Spindle driven Linear Axis range with a square, Aluminium hollow section with integrated, parallel, ground and hardened Steel guide rods.

- The carriage is driven by a rotating trapezoidal/ball screw threaded spindle connected to the carriage by a ball nut
- The carriage has play-adjustable ball-bearing rollers which engage with the guide rods
- The connecting slot between carriage and ball nut is covered by a stainless steel strip providing protection against splash water and dust ingress
- Lateral adjustment of movement for parallel units, or where twin carriages are mounted, is provided by the ball nut mounting

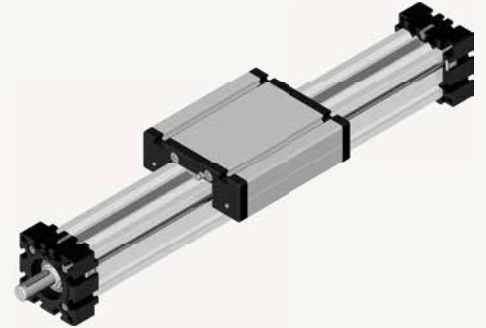

Spindle Drive



Double Roller - Single Guided



- 30 – 40 – 60 – 80 – 100 – 125 mm



- 3000 mm



- ± 1 m/s (K)
- $\pm 0,4$ m/s (T)



- 12000 N



- $\pm 0,025$ mm (K)
- $\pm 0,2$ mm (T)



- Low maintenance

EGT / EGK range

For Standard Industrial Applications

Spindle driven Linear Axis range with a square, Aluminium profile and sliding guides.

- The carriage is driven by means of a trapezoidal/ball screw threaded spindle with lead screw
- Guided by lateral V-slides that are adjustable free of play
- The linear opening of the unit is sealed with a stainless steel strip providing protection against splash water and dust ingress
- The leading-nut receiver can be used to adjust the symmetry of the carriages where two linear units are used in parallel or where twin carriages are mounted

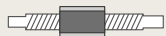

Spindle Drive



Sliding Guide



- 30 – 40 – 60 – 80 mm



- 3000 mm



- ± 1 m/s (K)
- $\pm 0,4$ m/s (T)



- 3500 N



- $\pm 0,025$ mm (K)
- $\pm 0,2$ mm (T)



- Low maintenance

Linear Axis - E Series

E Series ELZA/ELDZA range

For Standard Industrial Applications

Rack and Pinion driven Linear Axis range with a square, Aluminium profile and integrated hardened steel guide rods.

- The carriage runs on internal linear ball bearings that can be adjusted free of play
- The pinion is equipped with maintenance-free ball bearings
- The ELDZA range includes our innovative guiding profile which can be used effectively in combination with standardized toothed racks
- Multiple units can be assembled in series to achieve extended strokes

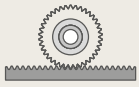

Rack and Pinion Drive



Double Roller - Single Guided



- 40 – 60 – 80 – 100 mm



- Up to 6 m (standard)
- Up to 20 m and longer (with axes joined in series)



- 3 m/s



- 2500 N



- $\pm 0,1$ mm



- Low maintenance

Additional ranges

Linear Axis with Tooth Belt Drive

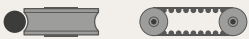

ELFZ



- Belt drive
- Pulley principle
- Vertical installation position
- Omega system

ELFZ EX



- Belt drive
- Ex guide
- Pulley principle
- Vertical installation position
- Omega system

ELHZ



- Internal belt drive
- Clean room
- Horizontal Tooth belt
- High dynamics

ELSD



- Belt drive with rotary shaft
- Omega system
- Vertical installation position
- Gripper adaptation
- Rotational movement

ELVZ



- Internal belt drive
- Clean room
- Vertical Tooth belt
- High dynamics
- Additionally with two carriages moving in opposite directions

Linear Axis - E Series

Additional ranges

Linear Axis with Tooth Belt Drive

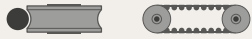

ELZ-W



- Higher profile stability
- Higher force fixture
- Long traverse path

ELZD-W



- Belt drive
- Higher profile stability
- Independent carriages
- Higher force fixture

ELZ EX



- Belt drive
- Universal system
- Ex-guide
- High speed

ELZG



- Tooth belt drive with revolving tooth belt
- Universal system
- Carriage to move in opposite directions from each other

ELZT



- Telescopic belt drive
- Omega system
- Vertical installation position
- Cantilever axis

ELZZ



- Belt drive
- Two separately driven carriages
- Universal system
- Higher force fixture
- Compact design

Linear Axis with Rack and Pinion Drive



ELZQ



- Rack and pinion drive
- High load capacity
- High rigidity
- Lifting system
- High operational reliability

Linear Axis without Drive



E



- Combination unit for use with single axis systems

ELR



- Combination unit for use with EL spindle multi axis systems

ELRZ



- Combination unit for use with EL belt multi axis systems

Linear Axis - D Series

DLZ range

For Heavy Duty Industrial Applications

Toothbelt driven Linear Axis range with a rectangular, Aluminium profile.

- Twin integrated roller guides ensure this range is suitable for heavy duty applications with heavy loads and high moments
- Each standard pulley has got one coupling claw on one side
- Belt tension can be readjusted by a simple screw adjustment device in the carriage
- Openings in the guide body are sealed with stainless steel cover bands providing protection against splash water and dust ingress (cover bands are optional)
- Multiple units can be assembled in series to achieve extended strokes (without cover bands)
- Certified for use in Clean room applications (ISO-5)



Tooth Belt Drive



Double Roller - Double Guided



- 120 – 160 – 200 mm



- 3800 N



- Up to 6 m (standard)
- Up to 20 m (with axes joined in series)



- $\pm 0,1$ mm



- 8 m/s



- Low maintenance

DSZ range

For Heavy Duty Industrial Applications

Tooth belt driven Linear Axis range with a rectangular, Aluminium profile.

- Twin integrated rail guides ensure this range is suitable for applications handling exceptionally heavy loads
- Each standard pulley has got one coupling claw on one side
- Belt tension can be readjusted by a simple screw adjustment device in the carriage
- Openings in the guide body are sealed with stainless steel cover bands providing protection against splash water and dust ingress (cover bands are optional)
- Multiple units can be assembled in series to achieve extended strokes (without cover bands)

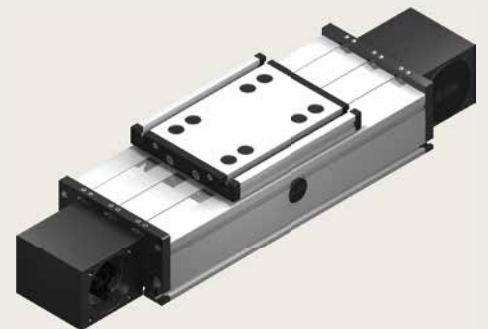

Tooth Belt Drive



Twin Rail Guides



- 120 – 160 – 200 mm



- 3800 N



- Up to 6 m (standard)
- Up to 15 m (with axes joined in series)



- $\pm 0,1$ mm



- 4 m/s



- Low maintenance

Linear Axis - D Series

DLT / DLK range

For Standard Industrial Applications

Spindle driven Linear Axis range with a rectangular, Aluminium profile.

- Twin integrated roller guides ensure this range is suitable for applications handling exceptionally heavy loads
- The carriage is driven by means of a rotating spindle with leading nut
- The leading-nut receiver can be used to adjust the symmetry of the carriages where two linear units are used in parallel or where twin carriages are mounted
- Openings in the guide body are sealed with stainless steel cover bands providing protection against splash water and dust ingress



Spindle Drive



Double Roller - Double Guided



- 120 – 160 – 200 mm



- 8000 N



- 3000 mm



- $\pm 0,025$ mm (K)
- $\pm 0,2$ mm (T)



- ± 1 m/s (K)
- $\pm 0,4$ m/s (T)



- Low maintenance

DST / DSK range

For Heavy Duty Industrial Applications

Spindle driven Linear Axis with a rectangular, Aluminium profile.

- Twin integrated rail guides ensure this range is suitable for applications handling exceptionally heavy loads
- The carriage is driven by means of a rotating spindle with leading nut
- The leading-nut receiver can be used to adjust the symmetry of the carriages where two linear units are used in parallel or where twin carriages are mounted
- The openings of the guide body are sealed with stainless steel cover bands providing protection against splash water and dust ingress (cover bands are optional)

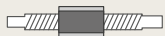
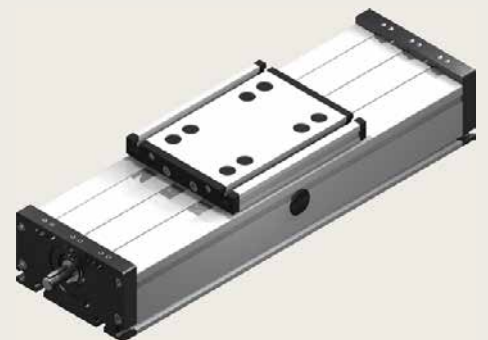

Spindle Drive



Twin Rail Guides



- 120 – 160 – 200 mm



- 8000 N



- 3000 mm



- $\pm 0,025$ mm (K)
- $\pm 0,2$ mm (T)



- ± 1 m/s (K)
- $\pm 0,4$ m/s (T)



- Low maintenance

Linear Axis - D Series

DLZA range

For Heavy Duty Industrial Applications

Rack and Pinion driven Linear Axis range with a rectangular Aluminium profile.

- Twin integrated roller guides ensure this range is suited to heavy duty applications with heavy loads
- The carriage runs on internal linear ball bearings that can be adjusted free of play and is driven along the guide rods by a high precision rack
- The pinion is equipped with maintenance-free ball bearings
- The rack and pinion system is suitable for highly dynamic servo operation and ideal for lifting applications
- Multiple units can be assembled in series to achieve extended strokes

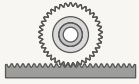

Rack and Pinion Drive



Double Roller - Double Guided



- 160 – 200 mm



- 3800 N



- Up to 6 m (standard)
- Up to 20 m and longer (with axes joined in series)



- $\pm 0,1$ mm



- 5 m/s



- Low maintenance

DSZA range

For Heavy Duty Industrial Applications

Rack and Pinion driven Linear Axis range with a rectangular Aluminium profile.

- Twin integrated rail guides ensure this range is suited to heavy duty applications with heavy loads
- The carriage is driven by a pinion on a high precision rack
- The pinion is equipped with maintenance-free ball bearings
- The rack and pinion system is suitable for highly dynamic servo operation and ideal for lifting applications
- Multiple units can be assembled in series to achieve extended strokes



Rack and Pinion Drive



Twin Rail Guides



- 160 – 200 mm



- 3800 N



- Up to 6 m (standard)
- Up to 20 m and longer (with axes joined in series)



- $\pm 0,1$ mm



- 5 m/s



- Low maintenance

Linear Axis - D Series

Additional ranges

Linear Axis with Tooth Belt Drive



<p>DLSZ</p>   <ul style="list-style-type: none"> • Belt drive • Omega system • Horizontal installation position • Off-center loads 	<p>DLVZ</p>   <ul style="list-style-type: none"> • Belt drive • Independent installation position • Special drive version • Space saving 	<p>DLZPVI</p>   <ul style="list-style-type: none"> • Belt drive • Planetary gearbox • Available with angular planetary gearbox • Cover profile
<p>DLZS</p>   <ul style="list-style-type: none"> • Belt drive • Omega system • Independent installation position • Lifting system 	<p>DLZS-P</p>   <ul style="list-style-type: none"> • Belt drive • Omega system • Independent installation position • Lifting system • Cover profile 	<p>DLZZ</p>   <ul style="list-style-type: none"> • Belt drive • With two separately driven carriages • Independent carriages • Horizontal installation position
<p>DSSZ</p>   <ul style="list-style-type: none"> • Belt drive • Omega system • Horizontal installation position • Off-center loads 	<p>DSZPVI</p>   <ul style="list-style-type: none"> • Belt drive • Optional with two driven carriages • Cover profile 	<p>DSZS</p>   <ul style="list-style-type: none"> • Belt drive • Independent installation position • Omega system • Lifting system
<p>DSZS-P</p>   <ul style="list-style-type: none"> • Belt drive • Omega system • Independent installation position • Lifting system • Cover profile 	<p>DSZZ</p>   <ul style="list-style-type: none"> • Belt drive • With two separately driven carriages • Independent carriages • Horizontal installation position 	

Linear Axis - D Series

Additional ranges

Linear Axis with Spindle Drive

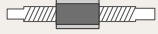

DLT-P / DLK-P



- Spindle drive
- Independent installation position
- Precision
- Cover profile

DST-P / DSK-P



- Spindle drives
- Precision
- Independent installation position
- Universal system
- Cover profile

Linear Axis with Linear Motor Drive



DLM



- Linear motor drive
- Roller guide
- High dynamics
- High repeat accuracy
- Long traverse path
- Independent carriages

DSM



- Linear motor drive
- Rail guide
- High dynamics
- High repeat accuracy
- Long traverse path
- Independent carriages

DSM-P



- Linear motor drive
- Rail guide
- High dynamics
- High repeat accuracy
- Long traverse path
- Clean room

Linear Axis without Drive

DLR



- Combination unit for use with DL multi-axis systems

DSR



- Combination unit for use with DS multi-axis systems

Linear Axis - Q Series

QLZ range

For High Spec Industrial Applications

Tooth belt driven Linear Axis range with a square, Aluminium profile and integrated hardened Steel guide rods.

- The carriage is driven by a timing belt and runs on an integrated roller guide
- Each standard pulley includes one coupling claw on one side
- Belt tension can be readjusted by a simple screw adjustment device in the carriage. This can also be used for symmetrical adjustment of two or more linear units running parallel.
- This linear unit is suitable for application in clean rooms of clean-room classification 1.000 (corresponding to US Fed. Standard 209 E).
- Certified for use in Clean room applications (ISO-6)

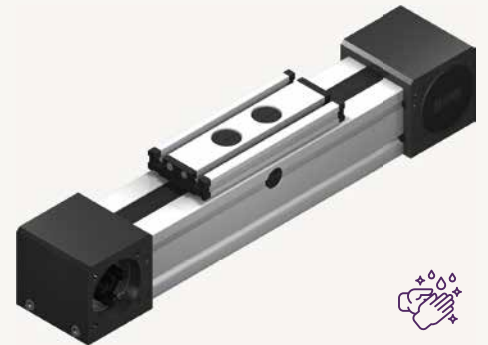

Tooth Belt Drive



Double Roller - Single Guided



- 60 – 80 – 100 mm



- 3800 N



- Up to 6 m (standard)
- Up to 20 m (with axes joined in series)



- $\pm 0,1$ mm



- 7 m/s



- Low maintenance

QSZ range

For High Spec Industrial Applications

Toothbelt driven Linear Axis range with a square, Aluminium profile.

- The carriage is moved by a belt drive and runs on an integrated ball rail
- Each standard pulley includes one coupling claw on one side
- Belt tension can be readjusted by a simple screw adjustment device in the carriage. This can also be used for symmetrical adjustment of two or more linear units running parallel.
- Certified for use in Clean room applications (ISO-1)

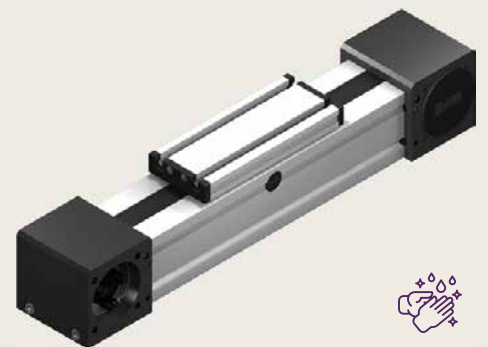

Tooth Belt Drive



Rail Guide



- 60 – 80 – 100 -125 mm



- 5750 N



- Up to 6 m (standard)
- Up to 15 m (with axes joined in series)



- $\pm 0,1$ mm



- 5 m/s



- Low maintenance

Linear Axis - Q Series

QST / QSK range

For High Spec Industrial Applications

Spindle driven Linear Axis range with a square, Aluminium profile.

- The carriage is driven by a rotating spindle with leading nut on an integrated ball rail
- High positioning accuracy and repeatability
- Can be used as a vertical axis in a gantry system for applications with restricted installation space
- Certified for use in Clean room applications (ISO-3)



Spindle Drive



Rail Guide



- 60 – 80 – 100 mm



- 3000 mm



- ± 1 m/s (K)
- $\pm 0,4$ m/s (T)



- 4000 N



- $\pm 0,025$ mm (K)
- $\pm 0,2$ mm (T)



- Low maintenance



QSK 80 - DSK 160 Multi Axis System

Linear Axis - Q Series

Additional ranges

Linear Axis with Tooth Belt Drive



QSSZ



- Belt drive
- Omega system
- Clean room

QSZT



- Belt drive
- Horizontal telescopic system
- High rigidity

Linear Axis without Drive

QLR



- Combination unit for use with QL multi-axis systems

QSR



- Combination unit for use with QS multi-axis systems

QSRZ



- Combination unit for use with QS belt multi-axis systems

QSSR



- Combination unit for use with QS multi-axis systems

Linear Axis - L Series

LLZ range

For Light Duty Industrial Applications

Tooth belt driven Linear Axis range with a square, Aluminium profile.

- The carriage is moved by means of an internal rotating tooth belt on an integrated roller guide
- The carriage runs on 5 roller guides which can be adjusted and serviced
- The pulley block contains coupling claws on both sides (standard version)
- Re-tensioning device for the tooth belt integrated into end cap
- Independent installation position

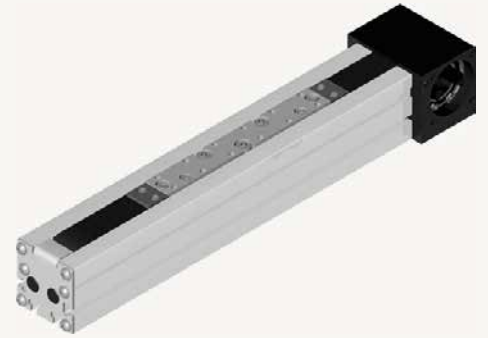

Tooth Belt Drive



Double Roller - Single Belt Guided



- 40 - 60 - 80 - 100 mm



- Up to 6 m (standard)
- Up to 20 m (with axes joined in series)



- 10 m/s



- 3800 N



- $\pm 0,1$ mm



- Low maintenance

LSZ range

For Light Duty Industrial Applications

Tooth belt driven Linear Axis range with a square, Aluminium profile.

- The carriage is moved by means of an internal rotating tooth belt on an integrated rail guide
- Includes timing belt deflection unit with integrated coupling claws integrated on two sides
- Re-tensioning device for the tooth belt integrated into end cap
- Independent installation position
- Multiple units can be assembled in series to achieve extended strokes
- Certified for use in Clean room applications (ISO-1)

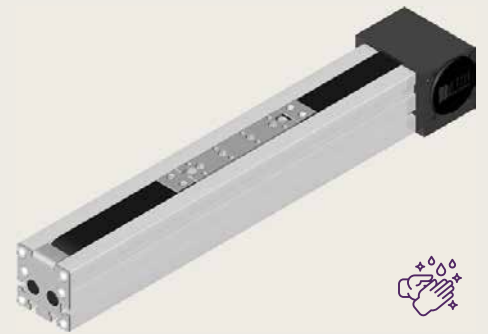

Tooth Belt Drive



Rail Guide



- 60 - 80 - 100 mm



- Up to 6 m (standard)
- Up to 15 m (with axes joined in series)



- 5 m/s



- 3800 N



- $\pm 0,1$ mm



- Low maintenance

Linear Axis - L Series

Additional ranges

Linear Axis with Tooth Belt Drive



LLN



- Belt drive
- Low operating volume
- Independent installation position
- Nubbed belt
- Low-vibration run

LLZS



- Belt drive
- Independent installation position
- Omega system
- Variable drive block

LSN



- Nubbed belt drive
- Low operating volume
- Independent installation position
- Low-vibration run
- For 3d printing applications

Linear Axis without Drive

LLR



- Combination unit for use with LL multi-axis systems

LSR



- Combination unit for use with LS multi-axis systems

Multi Axis - Twin Axis

ELZI range

Standard Multi Axis Systems

Tooth belt driven X/Z gantry consisting of a double guide in the horizontal X level and vertical Z axis.

- The unit is driven by a rotating belt, which remains connected through various deflection points. The belt is fixed and tensioned at the load end
- The movement is realised by two motors. The coordinate lies diagonal to the deflection points of the X axes and the Z axis
- Suited for pick and place applications requiring high acceleration
- Optionally available in reinforced version.

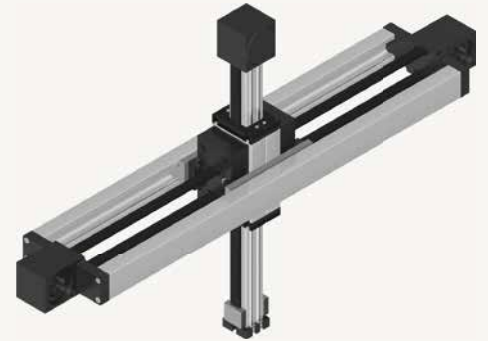

Tooth Belt Drive



Double Roller - Single Guided



- 30 – 40 - 60 mm



- X-Axis: 2000 mm
- Z-Axis: 1000mm



- 5 m/s



- 1800 N



- $\pm 0,1$ mm



- Low maintenance

ELZU range

Standard Multi Axis Systems

Tooth belt driven surface portal, consisting of 2 Y-axes and 1 X-axis.

- Driven by one rotating belt, which remains connected through various deflection points
- Positioning is achieved by two motors with coordinates diagonal to the deflection points of the Y-axis
- Suited to applications requiring high accelerations
- Optionally available in reinforced version.



Tooth Belt Drive

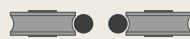

Double Roller - Single Guided



- 30 – 40 – 60 – 80 - 100 mm



- X-Axis: 3000 mm
- Y-Axis: 3000mm



- 8 m/s



- 3800 N



- $\pm 0,1$ mm



- Low maintenance

Multi Axis Systems

Multi Axis Systems are complemented with a range of drives, motors, cables, switches and other accessories.

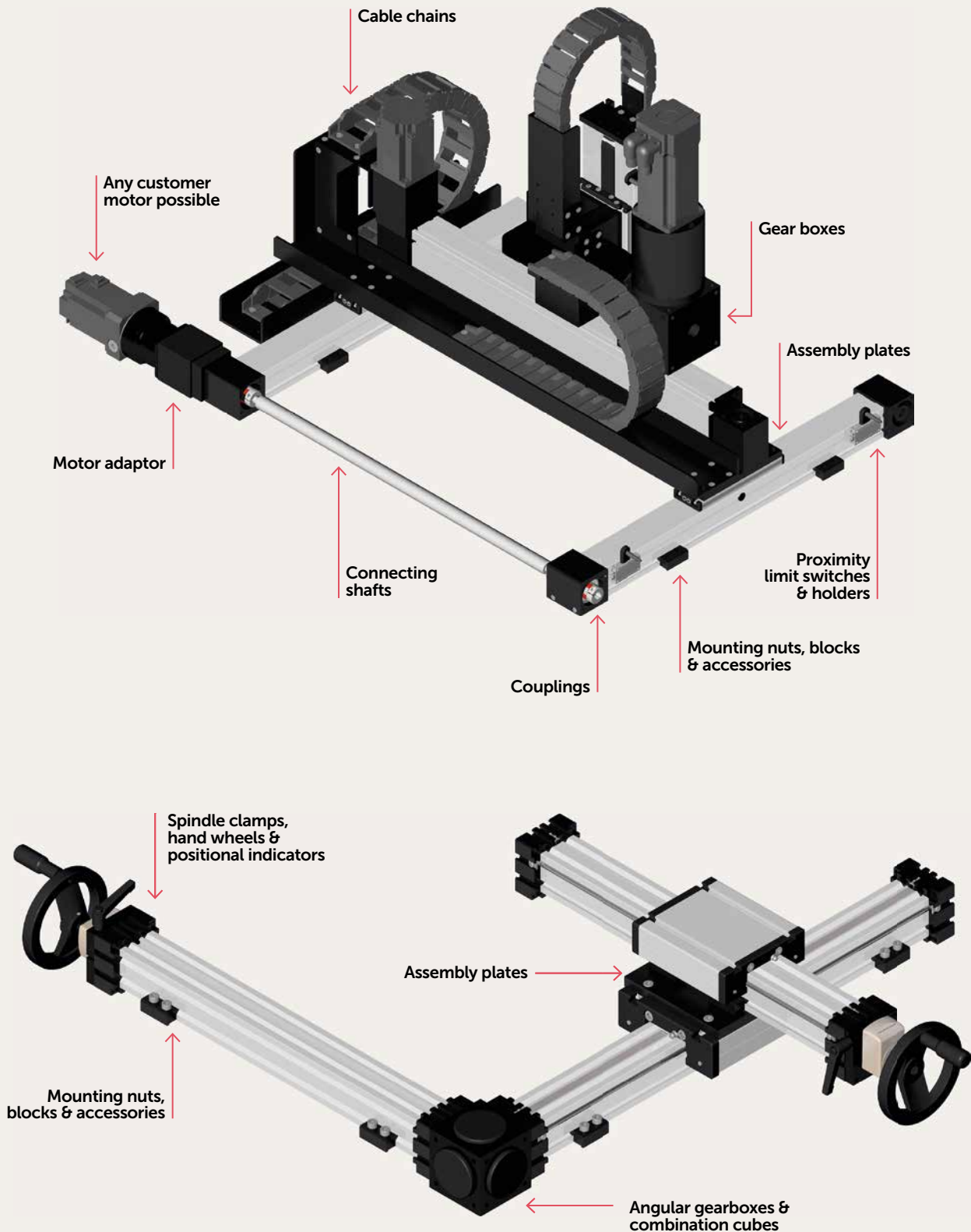











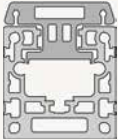

Endless Combination Possibilities

Complex multi axis systems are essential in today's industrial world, and they play an increasingly significant role in machine construction. To ensure we meet our customers' exact specifications, our experienced technical team are on hand to provide comprehensive needs assessment, advice and technical support from design through to delivery.

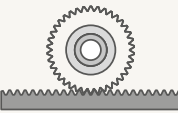
- Comprehensive requirement assessment and advice
- Fast quote: 48 hours with CAD models
- Standard project fulfilment target: 4 to 6 weeks
- Unlimited configuration
- On-site training and support
- Continuous customer service

Extensive product portfolio with more than 200 structural profiles, drive and guide systems and sophisticated accessories all enable endless configuration possibilities for single and multi axis systems.

Profile System	+ Guiding System	+ Drive System	+ Accessories	+ Certification	= Endless Possibilities
	Rail System 	Belt Drive 	Adaptors & Gearboxes 	Ex-Proof 	
	Slider System 	Spindle Drive 	Cable Chain 	Clean Room 	
	Roller System 	Rack and Pinion 	Parallel Transfer 	Anti Corrosion 	
		Linear Motor 	Limit Switch 	Low Temperature 	

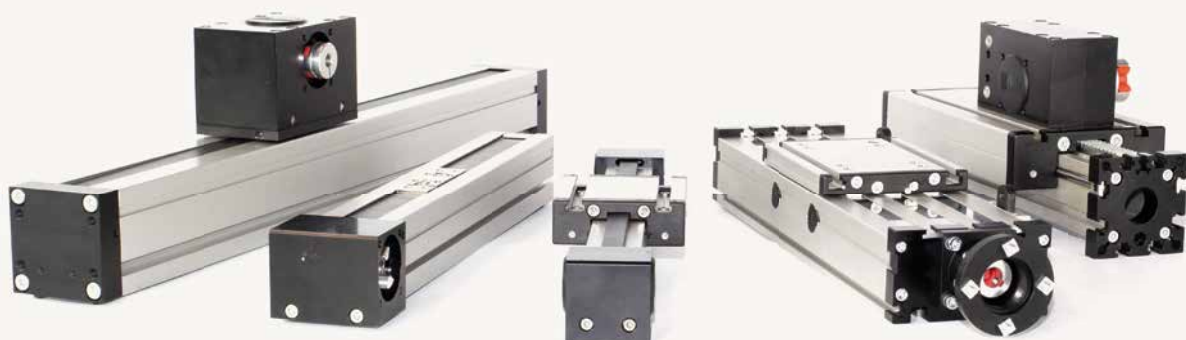



Manufactured in Luhden, Germany

●● Our expanded electric motion range now has over 1,000 products, offering more than 100 million design configurations.

Which gives you the ability to find the right solution for an even greater range of applications and performance demands. Improve speed, raise productivity, save energy or reduce cost of ownership. It's all easier to achieve with endless electric motion. ●●

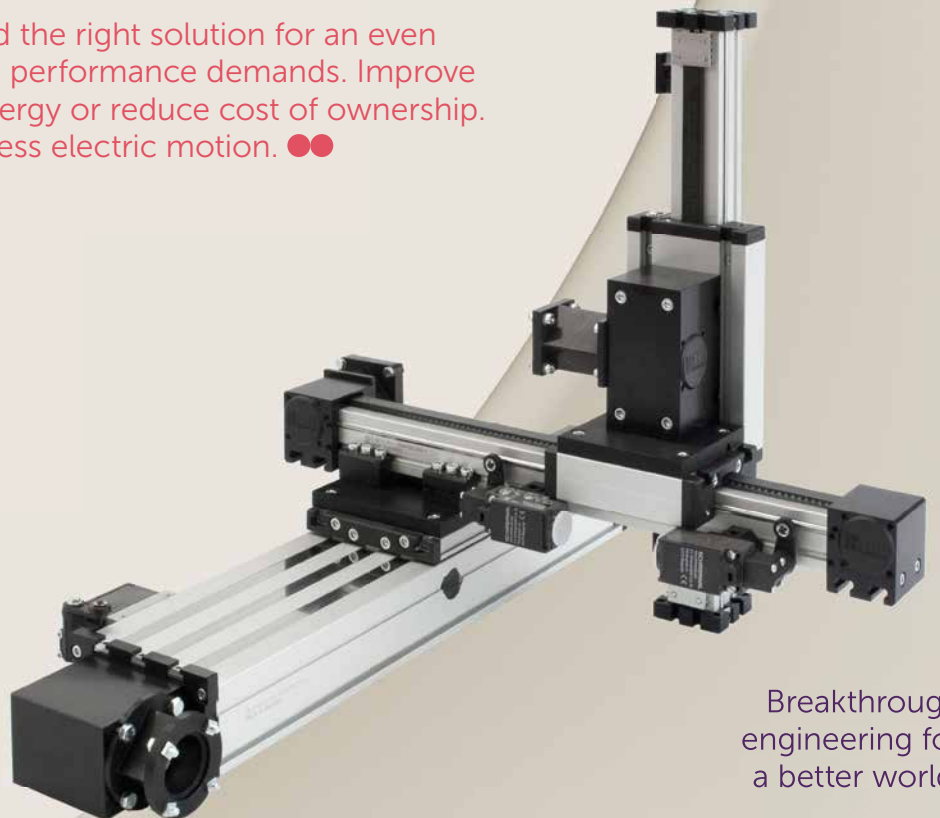

Breakthrough
engineering for
a better world.

Our Industrial Automation sector operates four global centres of technical excellence and a sales and service network in 50 countries, as well as manufacturing capability in Europe, Americas and Asia Pacific.

Supported by distributors worldwide.

For further information, scan this QR code or visit

www.imiplc.com/industrial-automation



Industrial Automation

IMI Norgren
IMI Bimba
IMI Bahr
IMI Buschjost

The information in this brochure is provided for informational and promotional purposes only and is provided "as is" and without warranties of any kind, whether express or implied, including but not limited to implied warranties of satisfactory quality, fitness for a particular purpose and/ or correctness.

Any specifications, features, pricing, or availability contained in this brochure are subject to change without prior notice. IMI plc does not represent or warrant that the information and/or specification in this brochure are accurate, complete, or current and therefore make no warranties or representation regarding the use of the content. IMI plc or one of its subsidiaries own all images, logos, product brands, and trademarks mentioned in this brochure. Unauthorised use, reproductions, or modification of this content is prohibited.

© Copyright IMI plc. All rights reserved.

z10205BR en/04/26

Selected Images used under license from Shutterstock.com & stock.adobe.com

